



HANDBOOK

on

Diplomas, Degrees and Other Certificates in Higher Education in Asia and the Pacific

2nd Edition



United Nations Educational,
Scientific and Cultural Organization
UNESCO Bangkok



HANDBOOK
on
Diplomas, Degrees
and Other Certificates in Higher Education
in Asia and the Pacific

2nd Edition



United Nations Educational,
Scientific and Cultural Organization
UNESCO Bangkok



Handbook on diplomas, degrees and other certificates in higher education in Asia and the Pacific. 2nd edition / Asia-Pacific Programme of Educational Innovation for Development, United Nations Educational, Scientific and Cultural Organization.
Bangkok: UNESCO Bangkok, 2004
360 p.

1. Higher education. 2. Diplomas. 3. Degrees. 4. Educational qualifications. 5. Guides.
6. Higher education institutions. 7. Educational systems. 8. Asia/Pacific.

378.2

ISBN 92-9223-013-1

© UNESCO 2004

Published by the
UNESCO Asia and Pacific Regional Bureau for Education
920 Sukhumvit Rd., Prakanong
Bangkok 10110, Thailand

Printed in Thailand

The designations employed and the presentation of material throughout the publication do not imply the expression of any opinion whatsoever on the part of UNESCO concerning the legal status of any country, territory, city or area or of its authorities, or concerning its frontiers or boundaries.

ACKNOWLEDGEMENTS

The Handbook on "Degrees and Other Certificates in Higher Education in Asia and the Pacific", first published in 1998 in collaboration with UNESCO Asia and Pacific Regional Bureau for Education and SEAMEO Regional Center for Higher Education and Development (SEAMEO-RIHED), has proved to be a useful reference in assisting university people and policy-makers to know higher education and qualification system, particularly in 20 countries, in Asia and the Pacific region, and four additional countries from other regions.

The Handbook has also served as a relevant tool in strengthening and sustaining the co-operation and development of higher education network among authors and other related personnel in different countries. It has provided information on higher education systems of identified countries, such as types of higher education institutions, co-ordination of higher education, institutional governance, as well as degree and diploma system, including types of degrees and diplomas, title and abbreviation of the degrees and diplomas. It also contained information on study programmes, admission requirements, degree conferring agencies, assessment of higher education institutions, degrees and professional competence, and international recognition of degrees.

In order to reflect changes that occurred in the past five years, collaborative efforts were undertaken to widen its coverage to 18 countries in the region. The countries included in the present Handbook are: Armenia, Australia, Brunei Darussalam, Cambodia, the People's Republic of China, India, Indonesia, Islamic Republic of Iran, Japan, Republic of Korea, Lao People's Democratic Republic, Malaysia, New Zealand, Philippines, Russian Federation, Singapore, Thailand, and Viet Nam. Additionally, it includes four other countries from outside the Asia and Pacific region, namely: France, Federal Republic of Germany, the United Kingdom and the United State of America, all contributors to the first edition.

I would like to extend my gratitude to all authors and collaborators of this present Handbook for their invaluable contributions. I would also like to thank Prof Dr Wang Yibing and Mr Chon-Hong Kim, for their efforts in starting this project, which I pursued along the direction they set. I acknowledge the valuable help provided by Ms Maleewan Skoonsuksade, Secretary to the APEID Unit.

My thanks also go to Mr Choi Jeenhar, Associate Expert in Higher Education, APEID Unit, without whose assistance this Handbook would not have been completed.

I would like to put on record my appreciation to Mr Francisco H Roque, Chief of the Publications Unit, and to Dr Cappia Taqueban, Technical Editor, from Kasertsart University, for their efforts in seeing the Handbook through its many phases.

Last but not least, my sincere thanks also go to Prof Dr Zhou Nan-Zhao, Co-ordinator of APEID Unit, for providing me the opportunity to compile the present edition of this Handbook.

If this book contributes to further mutual recognition of degrees and diplomas in the region, I will have at least partially fulfilled my duty as UNESCO staff. It is hoped that the next edition of this Handbook will include all countries in the Asia and the Pacific.



Fumihiko SHINOHARA
Programme Specialist in Higher Education a.i. and ICT for Education
UNESCO Asia and Pacific Regional Bureau for Education
Bangkok 10100, Thailand

EDITORIAL NOTES

Five years after the first publishing of the Handbook, the purpose of which was to conduct a survey of study programmes and of degrees, diplomas, and certificates granted by higher education institutions in Asia and the Pacific, this office has finally had the 2nd edition published, which covers 23 countries in the region and beyond. We are very grateful to the following 23 co-authors who have made this possible.

- *Karine Danielian* of the Republic of Armenia
- *Leo H.T. West* of Australia
- *Diana P.P. Cheong* of Brunei Darussalam
- *Pich Sophoan* of Cambodia
- *Bie Dunrong* of the People's Republic of China
- *Jandhyala B G Tilak* of India
- *Satryo Soemantri Brodjonegoro* of Indonesia
- *Abdolmajid Eskandari* of Islamic Republic of Iran
- *Akira Arimoto* of Japan
- *Hyun Chong Lee* of the Republic of Korea
- *Phob Phannolath* of the Lao People's Democratic Republic
- *Mohamed bin Suleiman* of Malaysia
- *Khin Maung Tint* of Myanmar
- *Jo Doyle* of New Zealand
- *Amelia A. Biglete* of the Philippines
- *Victor Chistokhvalov* of the Russian Federation
- *Lana YL Khong* of Singapore
- *Varaporn Bovornsiri* of Thailand
- *Lam Quang Thiep* of Viet Nam
- *Thierry Malan* of France
- *Gerdi Jonen* of Germany
- *Cloud Bai-Yun* of the United Kingdom
- *E. Stephen Hunt* of the United States of America

On completing this project, we wish to express our profound gratitude to Prof. Dr. Wang Yibing, Specialist in Higher and Distance Education, recently retired after 10 years of service to higher education activities in UNESCO Bangkok, and Mr. Chon-Hong Kim, Associate Expert in Higher Education, who worked for three years in APEID, UNESCO Bangkok, for their effort in planning for the update of the Handbook early this year. Also, our thanks go to the dedicated secretary for higher education in APEID, Ms. Maleewan Skoonsuksadee.

If this book contributes to further mutual recognition of degrees and diplomas in our region in the future, we will have at least partially fulfilled our duty as UNESCO staff. It is also hoped that the next updated edition of this Handbook will cover all countries in Asia and the Pacific.

Fumihiko Shinohara
Programme Specialist a.i. in Higher Education
UNESCO Bangkok

Jeen-Har Choi
Associate Expert in Higher Education
UNESCO Bangkok

Message

from the Director, UNESCO Bangkok

It has been five years since the Handbook on Diplomas, Degrees and other Certificates in Higher Education in Asia and the Pacific was published in September 1998 with the collaborative effort of researchers from 23 countries in the region and beyond.

However, as the mutual recognition of awards in higher education remains an increasingly pressing issue in the midst of tremendous quantitative expansion and massification of higher education in this region, with the accelerating pace of globalization of economy and the increasing pressure for more and better higher education as a key strategy to an information and knowledge society, this Handbook on information about degrees, diplomas, and certificates granted by higher education institutions needs an updating of the main issues, changes and progress related to higher education in each country.

It is a pleasure to have the 2nd Edition of the Handbook updated with the contributions of co-authors from 19 countries in Asia and the Pacific plus four selected countries from Europe and North America. Let me express UNESCO's sincere gratitude to all co-authors from the 23 countries for their contribution to the research to update the Handbook and to the colleagues and staff in APEID who co-ordinated their work.

It is anticipated that this handbook, available in published form as well as on-line, will be useful as a reference tool for policymakers and scholars in higher education across the Asia-Pacific region, providing insight into and promoting understanding of educational systems in different countries. It will also contribute to the implementation of the Regional Convention on the Recognition of Studies, Diplomas and Degrees in Higher Education in Asia and the Pacific which UNESCO established to enhance mechanisms for quality assurance and for the mutual recognition of awards in a regional context.

Lastly, I hope that the Handbook will be updated and published regularly to provide more timely and relevant information for policymakers, researchers, and related specialists in this world of ever-increasing diversity and change.

Sheldon Shaeffer

Director

UNESCO Asia and Pacific Regional Bureau for Education, Bangkok

CONTENTS

	<i>Page</i>
A	
<i>Asia and the Pacific Countries</i>	
1. Armenia.....	1
2. Australia.....	17
3. Brunei Darussalam.....	29
4. Cambodia.....	45
5. The Prople’s Republic of China.....	57
6. India.....	73
7. Indonesia.....	99
8. Islamic Republic of Iran.....	121
9. Japan.....	143
10. Korea, Republic of.....	157
11. Lao People’s Democratic Republic.....	173
12. Malaysia.....	187
13. New Zealand.....	207
14. Philippines.....	221
15. Russian Federation.....	237
16. Singapore.....	257
17. Thailand.....	271
18. Viet Nam.....	287
B	
<i>Appendixes</i>	289
1. France.....	301
2. Federal Republic of Germany.....	313
3. The United Kingdom.....	327
4. The United States of America.....	343
C	
<i>Directory of Co-authors</i>	345



A. Asia and the Pacific Countries

- Armenia
- Australia
- Brunei Darussalam
- Cambodia
- The People's Republic of China
- India
- Indonesia
- Islamic Republic of Iran
- Japan
- Korea, Republic of
- Lao People's Democratic Republic
- Malaysia
- New Zealand
- Philippines
- Russian Federation
- Singapore
- Thailand
- Viet Nam

1. COUNTRY PROFILE

The Republic of Armenia occupies a territory of 29,800 square kilometres with a population of 3,200,000 (2002). Armenian is the official language and the State religion is the Armenian Apostolic Church. The nation is a Republic with the National Assembly as the State Legislative Body and governed by a Council of Ministers. The capital is Yerevan and the currency is the dram.

Armenian Republic is a land-locked, mountainous country, located in the southern part of the Caucasus region. It is the smallest of the independent states of the Commonwealth of Independent States (CIS). Since the establishment of the national statehood in 1991, following the collapse of the former USSR, the country has experienced an extremely difficult economic situation, peculiar to the period of transition from a Soviet central planned economy to the market oriented and pluralistic society.

The situation was aggravated by the consequences of the 1988 devastating earthquake (25,000 dead, one-third of the country's territory affected), the military conflict in Nagorno-Karabakh, and as a result of the emerged hostility in the region, the imposition of a blockade of all trade and land transport by Azerbaijan.

During the past twelve years of political and socio-economic transformation a significant change of the in-country situation has been achieved. The step-by-step implementation of a comprehensive stabilization and structural adjustment reform programme since the beginning of 1994 outlined a trend in economic recovery and macro-economic stabilization. The peace process and reduction of regional tension established after the cease-fire agreement signed between Azerbaijan, Nagorno-Karabakh and Armenia on July 27, 1994, contributed to the efforts of the government in implementing the economic reform programme.

During more than a decade, almost all spheres of national life have undergone fundamental reforms. In the economic and democratic domains these reforms resulted in the creation and of a legislative framework and the established prerequisites that enabled the country to enter a qualitatively new phase of development. Armenia's aspirations on economic and social success are linked in the first place with the irreversible choice of democracy and the organization of the State, with major emphasis placed on the deepening of international integration.

Independence and transition to a market economy posed serious challenges to almost all post-Communist countries throughout the 1990s. Armenia was not an exception, and its path to an economically sound democracy has been strewn with missed and grasped opportunities, predicaments of various nature along with windows for success. The year 2001, which was particularly eventful for Armenia, was the evidence of that development,

meaningfully and symbolically integrating the “new” democracy with the centennial wisdom of the Armenian nation that was celebrated in the 10th anniversary of its independence together with the 1700th anniversary of the Declaration of Christianity as the State religion in Armenia.

On January 25, 2001, the Republic of Armenia has become a member of the Council of Europe, which considerably increased both the opportunity to enjoy European standards and values, as well as the responsibility of Armenia for the promotion of political stability, economic and social progress, democracy and human rights protection in Europe.

2. NATIONAL EDUCATION SYSTEM

Armenia has a literacy heritage dating back to 405 A.D., when the Armenian Alphabet was created by Bishop Mesrop Mashtots. To mention, the 1600th Anniversary of the Creation of the Armenian Alphabet is nominated for the celebration of anniversaries in 2005 in which UNESCO will be associated.

The history of Armenian literacy is closely connected to the history of the Armenian Christian Church, which during the centuries regarded education as a main factor in maintaining national identity. Up to the 18th century, all Armenian schools were founded and functioned under the auspices of the Armenian Church. During the 10th to 15th centuries, schools offering 10-12 years of education operated in a number of church centres, and some ten university like higher educational institutions were founded in different parts of historical Armenia. The universities provided education not only in philosophy, theology, and letters but also in translation techniques, mathematics, natural sciences, medicine, architecture, and music. The 700th anniversary of the University of Gladzor, one of the most celebrated of these institutions, was commemorated by UNESCO in 1984.

Located at the crossroads of Asian and European cultures, Armenian educational institutions combined Eastern philosophy with the ideas of European rationalism, humanism, and enlightenment. The development of Armenian letters and the arts was promoted by centres of learning that spread through a large part of Christendom, including ones in Cilicia, Constantinople, San Lazzaro (Mkhitarist Seminary in Venice is functioning until now), Echmiadzin (the Ecclesiastical Seminary of the Holy See of Echmiadzin), Tbilisi (the Nersissian School), Moscow (the Lazarian Seminary), Calcutta, Madras, and Rostov (Russia).

The first secular Armenian schools were opened in Armenia at the end of the 18th century. But lack of statehood had a negative impact on the formation and development of a national system of education and culture. The present day system of education was initiated during the short period of the first Republic of Armenia (1918-1920) and was later developed during the Soviet era from 1920 to 1990.

Since 1920, when the separation of church and state was concluded, the public schools have become entirely secular. With the formation of the Soviet Union in 1922, the Armenian educational network has been included in the all union educational system and, as a constituent part, shared in its characteristic strengths and weaknesses.

Education in Armenia has been traditionally highly rated. And today as well, the most important national issue is considered to be the maintenance and development of an education network, compatible with international standards. Therefore, some corresponding laws and decrees were adopted since the declaration of independence.

Article 5 of the Constitution of the Republic of Armenia (1995) claims that all citizens of the Republic of Armenia (RA) have the right to education; the secondary education in public schools is free; every citizen has the right to get higher or specialized education on competitive basis. On April 14, 1999, the National Assembly (Parliament) of RA has adopted the “Law on Education”, which is based on the constitution principles, gave definite direction to the development of a flexible network and from time to time undergoes some adjustments and amendments depending on education priorities.

In May 2000, the Government Decree has approved the national criteria for general education, according to which, the education quality in national school is under constant supervision. The “National Plan for Education Development for 2001-2005” was approved by the Parliament in June 2001. The main goal of the Plan is to ensure education progressive development, for it is the decisive factor for statehood enforcement and socio economic development of the society.

In addition, a number of norms and regulations on legal issues has been adopted. Nevertheless, the adoption of the laws during the recent three years did not provide an efficient development of the education system. The inadequate quality of the enforcement of laws and regulations, the absence of really operating mechanisms for proper protection for those involved in education, as well as the lack of financial, institutional and human resources considerably hinder a smooth development of the education network. The education network includes:

- a complex of different levels and orientation of education programmes that ensure education continuity in compliance with the national criteria;
- a network of different types of education institutions which are responsible for the implementation of such programmes;
- an education management system, including all the institutions and enterprises under the umbrella of the managing agency.

The present system of education of the Republic of Armenia includes:

- Pre-school education (children of age 3-6);
- General secondary education comprising of:
 - a. the primary school (grades 1-3),
 - b. middle or basic school (grades 4-9),
 - c. the high school (grades 10-11).
- Professional education comprising of specialized, vocational, higher and postgraduate education;
- Teacher training and retraining institutions.

2.1 Pre-school education

The main goal of pre-school education are to contribute to the child’s physical, moral and mental development, development of communication skills in the mother language and to ensure the capability for to study foreign languages based on the obtained skills in the mother language, development of basic counting and behavioural skills, knowledge about the surrounding nature and environment; manifesting the elements of own history and culture; ensuring a love and devotion towards the motherland; and, in general, preparation of the child to the school curricula.

The main role of pre-school education is prescribed to a family. Therefore, the government takes the obligation to ensure adequate family conditions for providing a child with corresponding care.

The state pre-school institutions are:

- day care (for children from age 2 to 3);
- kindergarten (for children from age 3 to 6); and
- combination of day care and kindergarten.

The pre-school education state network is currently represented by 825 community-based kindergarten schools and 19 are under the umbrella of the Ministry of Education and Science of RA with an enrollment of 51,905 and 996 children, respectively. There are also 21 non-state sector kindergarten schools.

The number of pre-school institutions has increased by 21% as compared with 1991. The enrollment, in the contrary, has considerably decreased. In 1991, the number of children attending kindergarten was 143,900, which was 39% of the children of that age group. In 2000, the overall kindergarten enrollment was 53,200, which was 21% of that age group. This means that after ten years, the enrollment has decreased by 18%, which is a direct result of the reduction of birth rate, hardships and economic difficulties, large scale migration, decrease in the quality of pre-school services and their affordability.

Currently, some 7,778 educators are teaching in the pre-school institutions with 92.6% of which are with specialized education, 34.2% are graduates of pedagogical universities.

In 1996, the ownership of the state-owned pre-school institutions have been handed over to the local government communities, and currently they get funded only from the community budget. This has had a negative impact on the pre-school institution operation, and, as a consequence, many of them have simply shut down.

The basic issue in the current pre-school institutions remains to be the shortage of funding, which results not only in low salary rates for the educators, but also makes impossible the replacement of the worn-out equipment with modern ones. A separate issue is the administration of operating pre-school institutions in the rural areas, because due to difficult economic conditions most of them do not function.

Taking into consideration that pre-school education has an ultimate impact on the mental and physical development of the child, and, therefore, upon the formation of a citizen and a full member of the society, the Ministry of Education and Science of RA made the issue of pre-school education its priority.

2.2 General secondary education

There are 1,429 state-owned general schools operating in Armenia. The 115 schools out of the high schools have the status of a college. The 56,062 teaching staff works in general schools and 85% of them are women. The teacher-student ratio currently is 1:10 in the Republic, and the administrative staff-student ratio is 1:20, which is low compared with the indicators of developing countries 1:17 and 1:25 respectively. The 72.9% of the teaching staff are graduates of universities, 17.2% are graduates of pedagogical colleges, 1.3% have Bachelor's Diploma, 5% are graduates of non-pedagogical universities and 3.5% are graduates of colleges.

General education is mainly funded by the national budget (Appendix 2). Besides the state-owned schools, 31 non-state schools are currently functioning with an enrollment of 2,979 students. There are 664 teaching staff working in these schools. The non-state education institutions do not receive allocations from the national budget. The general education is now experiencing ongoing reforms, which involves all aspects of the sphere: the structure, content, management, finance, etc. The financing is provided, on national level, both by budget and outside budgetary funds (All Armenian Foundation “Hayastan”, Social Investment Fund of Armenia), as well as by the sponsorship of the projects of the international organizations. Thus, within the general reform programme, the World Bank Credit funded “Education Finance and Management” programme, which was implemented through 1997-2002 is prioritized.

2.3 Professional education

Before 1990, professional education was free, and since 1992, institutions providing professional education implement paid education along with the state order, where education institutions define the rate of tuition fee independently. RA Government defines the level of non-paid education for each year, based on the demand for each category of specialists as well as budget allocations for professional education. The RA Ministry of Education and Science and the Ministry of Finance and Economy jointly define the levels of paid education for each year, based on the capacity of a certain institution, adequacy of available facilities, teaching staff, instructional materials, etc.

Entrance into the professional educational institutions is performed through competition. Students pass entrance examinations.

The following main professional education programmes are implemented in Armenia:

- primary professional education (or vocational education),
- middle-level professional education,
- higher professional education, and
- postgraduate education.

2.4 Primary professional education

The aim of primary professional education (or vocational education) is to train the students for jobs requiring primary professional qualifications, on the basis of general education. This education includes state and non-state sectors. The technical professional education is provided on the basis of basic or secondary general education in technical colleges. The education period is three or one year, respectively. Currently, the total enrollment of 56 technical professional colleges is 2,100 students. The number of technical professional colleges has decreased by 40%, and enrollment has decreased by 93.6% against the level in 1991.

The primary professional education network has undergone considerable changes, in terms of areas of specialization, which become more relevant to the economic development in the country. The professions related to the spheres of services, trade, and food industry were put on the list of professions, while the number of students in the industry or construction sector considerably decreased.

2.5 Middle-level professional education

The aim of middle-level professional education is to give the students the middle professional qualifications, on the basis of general secondary education, and provide deeper professional knowledge.

Middle professional education is performed by middle professional education institutions: colleges and vocational schools. Education in the middle professional education institutions is implemented in both modes, stationary and distant education. The length of education depends on the level of basic education of the students and the chosen profession from 1 year and 10 months to 4 years and 10 months. There are 127 professions taught in these institutions. The graduates are granted the qualification of *junior specialist*.

Currently, 77 state middle professional education institutions are functioning (together with 10 branches) with an enrollment of 28,048 students, and 62 non-state ones. The number of state middle professional education institutions has increased by 13.2% and the number of students has decreased by 31 % against the level in 1991. Nearly 5,180 teaching staff is involved in middle professional education institutions, 70% of which are women and 4% of the total education budget is allocated for the middle professional education institutions.

Due to the reforms that took place in middle professional education 0 new list of professions is approved, which includes 440 professions grouped in 28 professional groups. New regulations have been adopted for introducing a paid education and the Ministry of Education and Science of RA has approved the state criteria for middle professional education, as well as the model charter for the middle professional education institutions.

2.6 Higher and postgraduate professional education

Higher and postgraduate professional education is performed both by state and non-state education institutions, in stationary and distant education forms, on the paid and non-paid basis. The aim of higher education is to train and retrain highly qualified specialists, and to satisfy the individual's professional development needs. The university and postgraduate professional education budget allocation is almost 12 per cent of the education budget.

The reforms in higher and postgraduate professional education include the education structure, content and management. As an outcome of the reforms, three degree courses were introduced in three universities in the Republic, with Bachelor's degree, Master's degree and Postgraduate curriculum.

In many aspects, higher education is becoming more comprehensive: institutions are becoming universities; new professions (theology, arts, social sciences, etc.) are introduced; education is becoming more humanitarian; universities have more autonomy in management and finance.

The Government of RA has approved the criteria for higher professional education. All the instructors and professors of the professional education institutions should take an advanced skills course, at least once in five years, on mandatory basis and in a centralized way. These courses ceased to exist since 1991 mainly because of lack of funding, and now the issue of skills advancement of pedagogical staff is under the jurisdiction of the individual institution and the staff.

3. HIGHER EDUCATION SYSTEM

3.1 Types of higher education institutions

The Armenian system of higher education is represented by universities, academies, institutes and conservatory. There are 16 state universities and 73 non-state universities, where 42,505 and 19,755 students study, respectively. The number of state universities has increased by 14.2% against the indicator in 1991, though the number of students has decreased by 13%. Nearly 40% of the total number of students is in the non-paid sector. Nine universities of the Republic, currently operate postgraduate courses and doctor's courses, and in three universities there are master's degree classes, where 660 master's degree, 882 postgraduate students and 8 Ph.D. students study free of charge, and 694 master's degree and 159 postgraduate students study as paying students.

The university teaching staff consists of 4,507 professors and lecturers, out of which 415 are professors and 2,137 are docents. The teaching staff has decreased by 19.6% as compared with the 1991 indicator. The 28.3% of the pedagogical staff is women. Professor-student ratio is 1:6 currently. There are 3,651 professors in the non-state universities. The non-state sector activities are regulated by the enforcement of licensing and accreditation rules approved by the Government, which promotes competition in the sphere of higher education.

Since the establishment in 1992 of the American University of Armenia (AUA) as an affiliate of the University of California, which was created by the financial assistance of the Armenian General Benevolent Union and administrative assistance of the University of California, some other educational institutions of that kind were founded and are successfully functioning in Armenia. Those are:

- the Russian-Armenian (Slavic) State University established in 2000 on the basis of the "Agreement between the Government of the Russian Federation and Government of RA on the conditions of the foundation and functioning of the Russian-Armenian University in Yerevan" signed in 1997 in Moscow;
- the French University in Armenia set up in conformity with the terms of the agreement signed in 1995 between the Governments of RA and France, on cultural, technical and scientific cooperation which started its activity in 2000;
- the European Regional Academy in Caucasus established in 2002 on the basis of the French University in Armenia, as a postgraduate institution offering Master's Degrees.

3.2 Co-ordination of higher education

The education management system of RA experienced frequent and not always justified institutional adjustments and human resource replacements in the middle and upper levels. The Ministry of Education and Science of RA and the middle management level have been reshaped several times. Finally, the rights and duties of the authorities in charge of education management were precisely defined in the "Law on Education" adopted in 1999.

According to the Law, the education system management should be implemented on several levels. The Ministry of Education and Science of RA elaborates the education development plan and criteria; controls the implementation; ensures the development and publication of the general education programmes, curriculum, develops relevant projects, textbooks and handbooks; provides license and state accreditation to education institutions; elaborates model charters for the state education institutions; approves the qualification procedures for the pedagogical and management staff in the education institutions; develops the list of professions being taught; develops the state order level for general education, middle professional education and higher professional education; approves the entrance examination guidelines and controls their implementation in state-owned and licensed non-state middle and higher education institutions; approves the procedures of student knowledge assessment; approves the honour degrees and titles granted by the scientific councils of the licensed higher education institutions; develops the models of state graduation documentation at all the graduation levels; defines the guidelines for standards defining and considering foreign education documentations; ensures the formation of development plans for the state education institutions, the plan implementation and supervision; and approves the appointment and dismissal of county and community education department heads.

The regional education management is implemented by the local government through the county education departments, the assignment and replacement of which is agreed with the Ministry. These authorities ensure the state education policy enforcement within a county or community; they define the school age for children and ensure their enrollment in the education institutions. In addition, the county education authorities provide education facilities, their operation and maintenance.

Special tasks and responsibilities of the Ministry of Education and Science of RA are carried out by its affiliated agencies: the Research Institute for Education, the Research Centre for Higher Education Issues, the Institute of Pedagogy (former Teachers' Retraining Institute).

3.3 Institutional governance

Higher education institutions are guaranteed complete independence in all spheres of intra-university life: choice of internal structures, organization of the educational process, development of curricula and projects, application of educational technology and methods, research, scientific production, finance and other issues. The administrative rules and activities of each higher educational institution are defined by their legislation (charter, code, etc.) approved by highest government authorities.

Higher education institutions are independent in their decisions to open or close faculties and chairs, to determine education fees and the amount of tuition fees. The governing bodies at the higher education institutions are:

- University Administration,
- Scientific Council,
- Faculty or Department Council,
- Dean's Office, and
- Chair.

Institutions and universities are governed by the rector, who acts under the authority of the University Administration. The rector is responsible for the entire management of the institution.

The rector is accountable to the Ministry of Education and Science. He/she is appointed by the Ministry of Education and Science. The rector presents candidatures of vice rectors to the Ministry's Board.

The members of the University Administration are the rector, vice-rectors, deans and heads of chairs, representatives of students, as well as academic and non-academic staff acting under certain electoral procedures. The Scientific Council - the supreme collective body of the institution is a representative and decision-making body for all the population enrolled and employed by the university or institution. Deans, heads of chairs are elected by Scientific Councils. The Faculty or Department Council and Dean's Office are responsible for operational and educational activities within faculties. Professors and instructors are selected by Faculty Councils upon results of competition for vacancy posts. Each signs an employment contract with the rector. The duration of the contract is usually limited to five years. Chairs represent the first operational level function within faculties, they have methodological and discipline-oriented responsibilities and are accountable to the Faculty Council and the Dean's Office.

The academic and non-academic staff and students take part in the internal governance of institutions through their representatives in the Scientific Council and Faculty Council. In addition, there are trade union committees and Student Councils, which co-ordinate their activities with the university administration.

4. CHARACTERISTICS OF DEGREES AND DIPLOMAS

4.1 Types of degrees and diplomas

The graduates of Higher education institutions are awarded the appropriate degrees and diploma documents.

- **Bachelor's degree** - After four years of training, graduates of higher institutions receive a **Bachelor's Diploma**.
- **Master's Degree** - Bachelor's degree holders with high ratings have the opportunity to continue education in Magistracy for 2 years and awarded a **Master's Diploma**.
- **Specialist Degree** - A Five-year study programme, realized at the higher education institutions leading to the **Specialist Diploma**.
- **Intern Degree** - Graduates of medical universities could improve their practical experience in **Internatura** - minimum one year of a postgraduate study, on completion of which graduate is awarded with a Certificate for professional activity in medicine. Thereafter, **Ordinatura** - 2-3 years professional education, leading to **Clinical Ordinator Degree** with the appropriate certificate.

- ***Candidate of Sciences Degree*** - Postgraduate study of 3-5 years is realized in *Aspirantur*. On completion of an independently elaborated thesis and its final presentation, graduates of *aspirantura* receive a certificate of *Candidate of Sciences*.
- ***Doctor of Sciences Degree*** - Education in *Doctorantura* is the highest level of an academic career, requiring defence of a thesis on a major scientific/academic problem of substantial importance. The *Doctorantura* leads to the qualification of ***Doctor of Sciences***.

4.2 Title and abbreviation of the degrees and diplomas

Degrees and diplomas are awarded in the following disciplines:

- ***Natural Science*** (Mathematics, Physics, Chemistry, Biology, Geography, etc.)
- ***Humanities-Social Sciences*** (Philosophy, Sociology, Psychology, Culturology, Politics, History, Arts, Law, International Relations, Journalism, Languages, Literature, Theology, etc.)
- ***Medicine***
- ***Culture and Arts*** (Theatre, Dancing, Music, Translation, Cinematography, Design, Advertisement, etc.)
- ***Economics and Management*** (National Economics, World Economics, Accounting, Governance, Commerce, Marketing, Statistics, Business Management, etc)
- ***Engineering***
- ***Construction and Architecture***

4.3 Information contained in the document

The Diploma document mentions the name of the recipient of the degree, the period of study (that is, year of study), the institution to which the recipient had been admitted, the field of study (or field of specialization), and the university or college conferring the diploma. There are two types of diplomas: (a) With Honors which is red and (b) Ordinary, a blue one. The Diploma document is signed by the Chairman of the State Examination Commission, the Rector of the institution conferring the diploma and the Dean of the Faculty.

The Diploma document mentions that the recipient of the Diploma of Higher Education “is entitled by this Diploma to carry out professional activities of any kind connected with the above mentioned qualifications and specialization”. There is also an Annex to the Diploma with an indication of the Graduation Thesis and titles of learned subjects, evaluation marks and hours.

5. STUDY PROGRAMMES

5.1 Number of credits

No credit system exists in the higher education system of the Republic of Armenia. There are special requirements in terms of number of hours to be passed before completing the subject course. These requirements vary as every single institution of higher learning decides on its own the curricula and syllabi and the necessary number of hours for passing the subject courses. For example, the Yerevan State University, on average, requires 5,500-5,600 hours in 4 years of study (i.e., 1,375-1,404 hours per year) for obtaining a Bachelor's degree; 1,200-1,300 hours in 2 years of study (i.e., 600-650 hours per year) for obtaining a Master's degree. However, there are no fixed hour requirements for the Doctor's degree, which is realized in 3 years.

The State Engineering University, on average, requires 4,200-4,700 hours in 4 years of study (i.e., 1,050-1,200 hours per year) for obtaining a Bachelor's degree; 1,800-1,900 hours in 2 years of study (i.e., 900-950 hours per year) for obtaining a Master's degree. There are no fixed hour requirements for the Doctor's degree, which is also realized in 3 years.

The duration of study for obtaining degrees and diplomas in specific fields varies according to different institutions. However, on average, the number of years and semesters are as follows:

- Bachelor's degree - 4-5 years (8-10 semesters)
- Master's degree - 2 years (4 semesters)
- Doctor's degree - 2-3 years (4-6 semesters)

5.2 Sequence of the study

The "Law on Education" of the Republic of Armenia states that "the Republic of Armenia carries out general and professional educational programmes". The Law stipulates the following sequence of the study in general and professional education:

- General Education
 - (a) pre-school education
 - (b) primary school
 - (c) middle or basic school
 - (d) high school
- Professional Education
 - (a) primary professional education (or vocational education)
 - (b) middle-level professional education
 - (c) higher professional education
 - (d) postgraduate education

5.3 Practical experience

Practical experience is a part of the curriculum in every higher education institution. The component of the practice varies depending on institutions. For example, the Institute of Pedagogy

requires a semester of practice at school at the end of the last year of study. An average duration of practical studies, which is a part of the curriculum in the higher education institutions is one to four months. However, in special fields, like medicine, the students are entitled to one year of initial supervised practice (Internatura) after completion of higher education.

5.4 Grading and evaluation

The grading system in all higher educational institutions is the same - based on a grading scale of 1 to 5 where:

- 5 = excellent
- 4 = good
- 3 = satisfactory
- 2 and lower = failed

A cumulative grade point average (GPA) of not less than 3.0 of the 5-point grading scale is required for obtaining a Bachelor's diploma. If it is lower than 3.0, the student is required to retake the failed examination. The evaluation system is based on semestral examinations which are supposed to assess the student's knowledge of the taken semester courses in a given subject. In case the examination is failed by the student, he/she has an opportunity to take it twice. If the result is again unsatisfactory, he/she is required to retake the whole course. The semester examinations are also based on the 5-point grading scale. For a Master's degree, a GPA of not lower than 4.0 is required. Moreover, in order to be admitted to the Master's programme, one must have a GPA of undergraduate studies not lower than 4.0.

6. ADMISSION REQUIREMENTS

Admission is on the basis of success in a competitive entrance examination and possession of the Certificate of Completed Secondary Education or its equivalent from a vocational training or secondary specialist institution. No open admission procedure is practiced.

The Government adopts the state order for the preparation of specialists, and also the admission procedure which has to be prepared and presented by the Ministry of Education and Science.

7. DEGREE CONFERRING AGENCIES

The individual institutions of higher education confer the degrees. They are authorized to do so when the course programme has been approved by the Ministry of Education and Science of the Republic of Armenia. Students receive the degree after they have passed the final State Examination, which normally covers the main specialized subjects of the whole four-or five-year study programme. A State Examination Commission is established and approved by the Ministry of Education and Science. Among the members of the Commission are the Rector of the Institution and the Dean of the Faculty. The Head of the Commission is appointed by the Ministry of Education and Science. The composition of the Commission is subject to the Ministry's approval.

8. ASSESSMENT OF HIGHER EDUCATION INSTITUTIONS

The “Law on Education” states that the Ministry of Education and Science is responsible for the procedure for the establishment, reorganization, liquidation and registration of the educational institutions. It is also responsible for accreditation, licensing, certification and registration of the educational institutions. Private institutions can be established but they have to obtain a state licence which is granted by the Ministry of Education and Science on the basis of a simple assessment process. The main criteria to be met by the private institution in order to be licensed is that the curriculum and educational standards of the private institution is in accordance with current state legislations on education.

9. DEGREES AND PROFESSIONAL COMPETENCE

In most fields, the higher education degree is considered as a prerequisite for practicing the corresponding profession. No additional requirements for training and professional practice is obligatory to be able to practice in such professions as engineering, law, and teacher education. The degree holders are free to obtain additional training as they desire.

In some professions, for example, in the field of medicine, students are entitled to pass one year of supervised professional practice, called *Internatura*, to obtain additional knowledge and skills in their specific field of study. Depending on the specialization, they should pass an additional training at *Clinic Ordinatura*, with a duration of two to four years.

In order to obtain a licence they should pass an examination on completion of *Internatura* and *Ordinatura*. For this purpose an Examination Commission is composed of representatives of the Ministry of Health, which decides whether the applicant is suitable to hold a licence. The licence is issued by the Ministry of Health of the Republic of Armenia.

10. INTERNATIONAL RECOGNITION OF DEGREES

The Republic of Armenia is a signatory of the UNESCO Regional Convention on the Recognition of Studies, Diplomas and Degrees in Higher Education in Asia and Pacific as well as the Convention on the Recognition of Studies, Diplomas and Degrees in Higher Education in the State belonging to the European Region. The Republic of Armenia also adheres to the Convention Against Discrimination in Education. The appropriate notifications were deposited to the Director-General of UNESCO on September 5, 1993.

REFERENCES

United Nations Development Programme (UNDP), *National Human Development Report: Armenia 2001*, Yerevan, 2001.

Department of Higher Education, Ministry of Education and Science of the Republic of Armenia, *Law of the Republic of Armenia on Education*, Yerevan, 2000.

Education in Armenia, Yerevan, 2002.

STRUCTURE OF THE EDUCATION SYSTEM OF ARMENIA

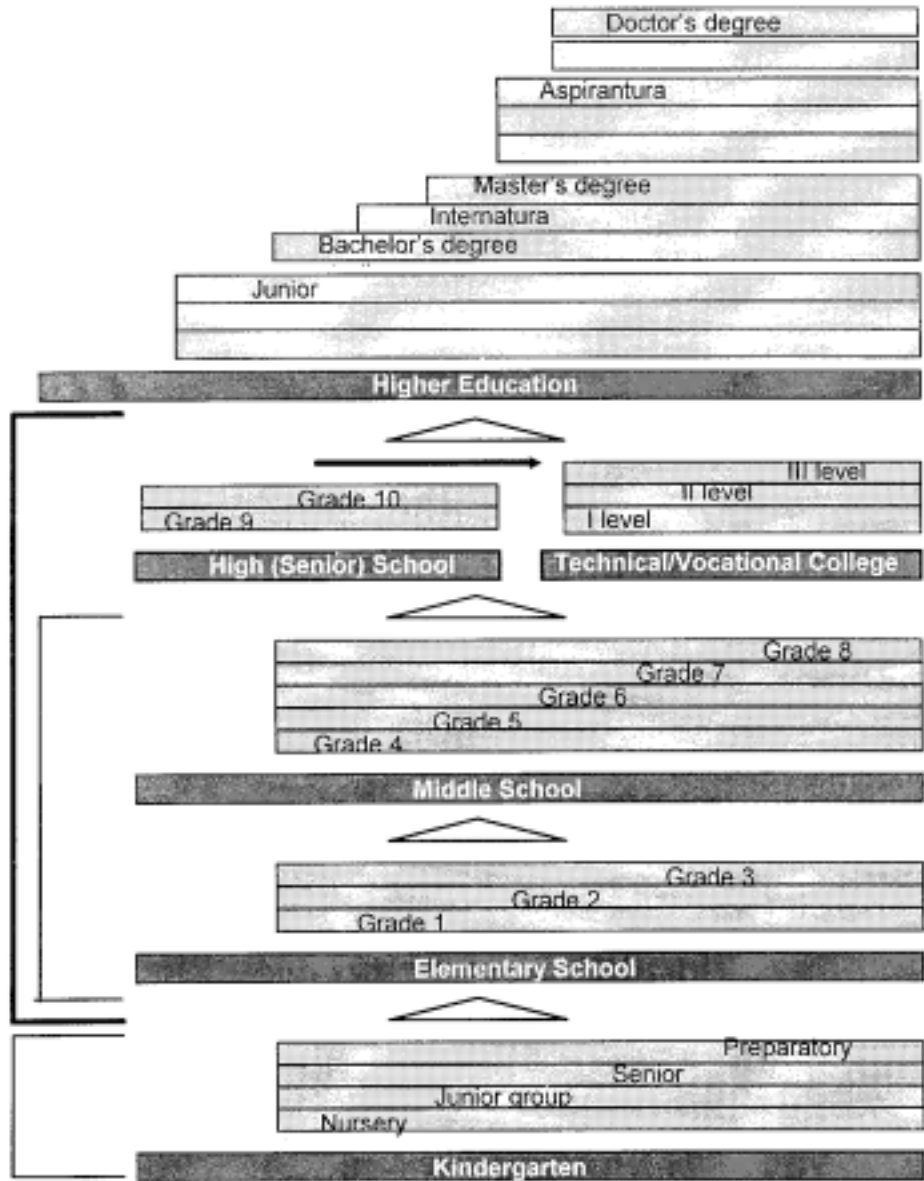

THE STRUCTURE OF THE UNIVERSITY EDUCATION SYSTEM

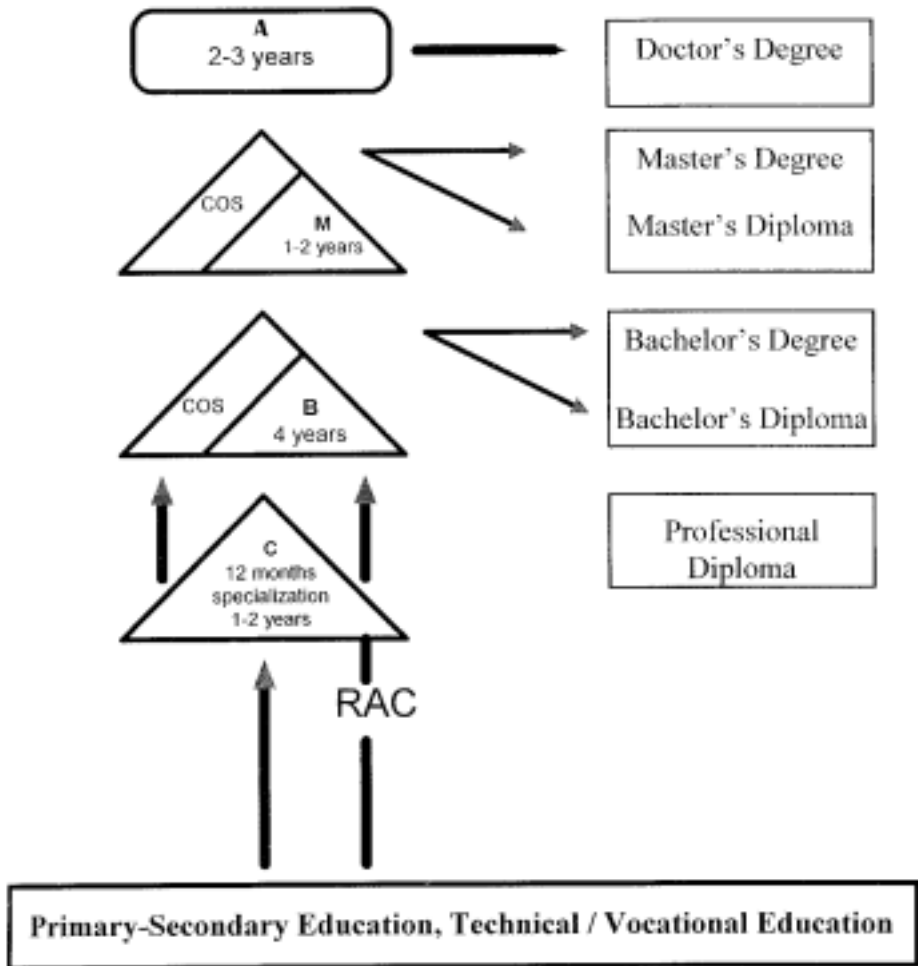

- A - Aspirantura
M - Master's degree studies
B - Bachelor's degree studies
C - College
RAC - Republican Assessment Centre
COS - Controlled Optional Subjects

1. COUNTRY PROFILE

Australia, both a continent and a country, is located between latitudes of approximately 12 and 44 degrees south and between longitudes approximately 110 and 155 degrees east. It has a land area of 7,617,930 square kilometres and has a population of 20 million. It is located in both the Pacific and Indian Oceans.

Australia is a federation of six States (New South Wales, Queensland, South Australia, Tasmania, Western Australia and Victoria) and two Territories (the Australian Capital Territory and the Northern Territory). Tasmania is an island in the south-east; all other states and territories are on the mainland. The Federal Government, based in Canberra, has acquired a range of responsibilities from the States over the years since federation (Income taxation is an example). However, each of the States and Territories has retained substantial, if not autonomous responsibility for, among other things, health, education and police.

In the case of education, it remains the legal responsibility of the States, although since the Federal government provides some funding to the various levels of education it has chieved a role in influence and policy. This is especially the situation in the case of higher education where the Federal (central) Government provides the majority of the funding

2. NATIONAL EDUCATION SYSTEM

A feature of the Australian education system is that it is not a national system. As noted above, responsibility for education rests with the States and Territories. In addition to the direct fiscal power of the Federal government, there is also a set of national programmes with earmarked Federal funding, and there is a national committee of Ministers of Education (State and Federal). These influences have led to the convergence of State and Territory education structures, but there remains much autonomy and many differences.

These differences are greatest at the school level. As a noteworthy example, school curricula vary across each State and Territory. Even on broad structures there are variations. All States and Territories offer Early Childhood, Primary (Elementary) and Secondary Education. In some States and Territories, Early Childhood and Primary Education are integrated, in others they are not. This can lead to apparent differences in commencing ages. In some States and Territories, the year split between primary and secondary is 6 years/6 years; in some it is 7 years/6 years; in others there is a split in secondary into lower secondary and upper secondary.

With all of the above discussion as qualification, the 'National' Education System can be summarised as follows:

- Pre-school education is available for students three to four years old. Primary school commences at age five and is usually six years in length. It is compulsory.
- Secondary schools are separate from primary schools and provide a further six years of education. Schooling is compulsory to age 16.
- Technical and Further Education (TAFE) colleges provide vocational education for school-leavers and adults with various levels of qualification. They also provide pathways to higher education.
- Universities offer undergraduate (bachelor's degrees) and a range of postgraduate diplomas and degrees. There are various pathways to entry. Entry directly from school to undergraduate programmes is based on State and Territory conducted end-of-schooling examinations and some school-based assessments.

In all segments - Pre-school, Primary, Secondary, Vocational and Further Education and Universities there are private as well as public providers.

3. HIGHER EDUCATION SYSTEM

3.1 Types of Higher Education Institutions

There are 39 self-accrediting universities in Australia, 37 of which are public and 2 are private. These are all comprehensive universities offering undergraduate and postgraduate degrees, including doctorates. All are research and teaching institutions. In addition, there are 4 single-purpose higher education institutions (e.g. Australian Maritime College) which are self-accrediting¹. Other organisations can offer degrees accredited by State and Territory governments for set periods of time (e.g. in Victoria, the period is five years with provision for re-accreditation). These institutions, referred to as non-self-accrediting institutions or private providers, tend to be professional associations (e.g. Institute of Chartered Accountants in Australia), government training bodies (e.g. Bureau of Meteorology Training Centre), and religious organisations (e.g. Catholic Theological College).

Many of the universities offer programmes through distance education. A separate agency, Open Learning, a company owned by a subset of the universities provides open learning programmes utilising degrees offered by its member universities.

3.2 Co-ordination of Higher Education

Universities as Autonomous Institutions

Universities are established under State or Territorial Acts. All are autonomous institutions governed by their Council or Senate. However, there are a number of bodies that have influence over the universities and which monitor universities' operations and performances.

State and Territory Governments

Each State and Territory has a Minister and Department responsible for education in that State and Territory. Usually, the higher education aspect is managed under a higher education office

(names vary). At the broadest level, the role of each of these offices is to assist the State/Territory Minister to fulfil her/his responsibilities for higher education. While there are some differences between States and Territories in the operationalisation of this broad function, the responsibilities generally include:

- Development of policies to enhance the provision of higher education in the State/Territory. The latter would include, for example, priorities for provision of higher education via new campuses of public universities.
- Monitoring of the impact of Federal governments funding and policies in higher education.
- Provision of advice to the Minister, government agencies and the public on higher education matters.
- Regulatory functions, for example, university land transfers, university loans, tabling of universities' annual reports to parliament, changes to university Acts, etc.
- Monitoring of the performance (including financial performance) of State/Territory universities. Council/Senate appointments and statutes.
- Accreditation of private higher education providers.

Federal Government

The Federal government's Department of Education Science and Training (DEST) has a higher education division. DEST coordinates the allocation of Federal resources (around 50 per cent of the income of public universities) for operating, capital and research purposes. DEST achieves these functions through a funding model based on a rolling triennium, accountability through the submission of annual educational profiles, and competitive allocation of research funding which is undertaken in partnership with the Australian Research Council.

DEST describes the profiles process as:

'During annual educational profiles discussions between the Department and Australian institutions, an assessment of higher education institutions for the purpose of allocating Commonwealth funding is undertaken. Operating grants are determined on the basis of total number of Commonwealth-funded student places that an institution is expected to deliver in a given year, taking into account the discipline and level mix of an institution's provision. Institutions are also expected to deliver a minimum number of equivalent full-time undergraduate student places. From 2002, institutions will be required to have submitted an approved research and research training management report in order to be eligible for block funding for research and research training.'

Institutions are also required to submit a range of documents in preparation for the profiles negotiations. These include:

- a statistical return covering teaching activities and number of student places;
- a research and research training management report;
- a quality assurance and improvement plan;
- an equity plan;

- an Indigenous education strategy; and
- a capital management plan.

DEST publishes an annual report on the higher education system which includes:

- an overview of the higher education sector in the previous year, including new Government policies and initiatives and recent developments in the sector;
- a review of the performance of higher education institutions in delivering student places and other Commonwealth-funded outcomes in the previous year; and
- information on the allocation of funding for the next triennium.

Australian Qualifications Framework

The nature and nomenclature of qualifications are standardised by the Australian Qualifications Framework (AQF)². AQF was established by the Ministerial Council of Ministers of Employment Education Training and Youth Affairs (MCEETYA)- consisting of State, Territory and Commonwealth Education and Training Ministers. The AQF define 12 qualifications, of which Diploma, Advanced Diploma, Bachelor Degree, Graduate Certificate, Graduate Diploma, Masters Degree and Doctoral Degree apply to Higher Education. Qualifications offered by Australian universities comply with the standards set out by AQF.

3.3 Institutional Governance

Australian universities are governed by a body sometimes called the University Council and sometimes the University Senate. These bodies are independent and have appointees representing various community groups and the State or Territory government with which the universities are established by an Act of Parliament. The Act specifies the size of and how members of the Council/Senate are appointed or elected. There is considerable variation across universities.

The Council is responsible for all aspects of the university's governance but is not involved in its management. The Council is the body that approves courses leading to degrees and diplomas and confers the university's degrees and diplomas. It appoints the Vice-Chancellor and approves all senior appointments and promotions. Usually a member of Council would be on the selection committee for any professorial appointment. It would approve the strategic plan and annual operational plans. It oversees the financial performance of the university.

4. CHARACTERISTICS OF DEGREES AND DIPLOMAS

4.1 Types of Degrees and Diplomas

The nature of qualifications offered by Australian universities is decided by their governing bodies, so there is some variation between universities. The Australian Qualifications Framework mentioned earlier (which replaced a previous structure - the Register of Australian Tertiary Education) provides a framework which describes the characteristics of learning outcomes for each qualification type, and describes the range of programme structures including their length that exist within each qualification type.

Diploma

The undergraduate diploma has almost disappeared from Australian universities. It was a first qualification in some areas of professional practice, for example nursing, teaching, and the

performing arts, but has now been replaced in these areas with bachelor's degree programmes.

Bachelor's Degree

The Bachelor's degree provides initial preparation for professional careers and postgraduate study.

The AQF describes the characteristics of the learning outcomes of the Bachelors degree as follows.

- 'the acquisition of a systematic and coherent body of knowledge, the underlying principles and concepts, and the associated communication and problem-solving skills;
- development of the academic skills and attributes necessary to undertake research, comprehend and evaluate new information, concepts and evidence from a range of sources;
- development of the ability to review, consolidate, extend and apply the knowledge and techniques learnt, including in a professional context;
- a foundation for self-directed and lifelong learning; and
- interpersonal and teamwork skills appropriate to employment and/or further study.

A course leading to this qualification also usually involves major studies in which a significant literature is available. Course content is taken to a significant depth and progressively developed to a high level, which provides a basis for postgraduate study and professional careers.³

The 'normal' generalist Bachelor's degree in the Arts (Bachelor of Arts, B.A.) and sciences (Bachelor of Science, B.Sc.) is a three-year full-time course beyond secondary school⁴, with an honours degree available (see below). The term 'generalist' here is used in the sense that the nomenclature covers a wide range of possible disciplines. Thus, the name 'Bachelor of Science' could refer to a degree with a major in chemistry, or in physics, or in biology, and so on. The specific degree, however, might be very specialised. The Bachelor of Economics (B.Ec.) and the Bachelor of Commerce (B.Com.) are similar with more professional orientation but still a generalist qualification. These qualifications are characterised by the study of one major field in each of the three years (with an increasing proportion of the year focusing on the major as the student progresses from first to third year), one or two minor fields (at least two years of study), and a range of other units⁵ chosen from across a broad field of study (Arts, Economics or Science) with some capacity to study units from any field of study. There has been a tendency in recent years for more narrow degrees to emerge, for example, the B.Sc. (Biological Sciences) or B.A. (Asian Studies) which, although still generalist in nature have a more restricted range of disciplines available.

The professional Bachelor's degrees are more structured and focused on the professional field of study.

Some are **three years** in length, including:

- Bachelor of Business (B.Bus.), usually specialising in a field such as Accounting, Banking, etc., and carrying the specialist name- Bachelor of Business (Accounting), etc;

³ www.aqf.edu.au/bmdguide.htm

⁴ There are alternative pathways, eg from a Diploma or Advanced Diploma in vocational education which provide advanced standing.

⁵ Different universities use different nomenclature: some use

- Bachelor of Nursing (B.Nurs.);
- Bachelor of Teaching (B.Teach.);
- Bachelor of Computing (B.Comp.).

Some are **four years** in length, including:

- Bachelor of Engineering (B.Eng.)- sometimes this qualification also includes the field, such as B.Eng. (Chemical); sometimes it does not;
- Bachelor of Laws (L.L.B.);
- Bachelor of Agriculture, Bachelor of Agricultural Science, etc. (Sometimes B.Agr.Sci, B.Agr, B.Sc. [Agr.]).

Some are **five years** in length:

- Bachelor of Architecture (Usually B.Arch., but can be B.Sc.(Arch.), B.Build.Env., etc);
- Bachelor of Dentistry/Bachelor of Dental Science (B.D.S., B.D.Sc.);
- Bachelor of Veterinary Science (B.V.Sc.).

Medical degrees are **six years**, yielding two degrees - the Bachelor of Medicine and the Bachelor of Surgery (Usually M.B.,B.S.).

Honours Degrees and Degrees with Honours

The three-year B.A., B.Ec., B.Sc., etc., are sometimes known as 'pass' degrees. Students may elect (following selection based on performance) to complete another year to obtain a B.A.(Hons), etc. The 'honours' year is a mix of specialist units and a research project requiring a thesis. Some universities have an integrated honours in which selected students embark on a four-year programme from early in the degree (say, after first year).

The three-year professional bachelor's degrees are beginning to offer an honours year.

The four-year and longer professional degrees usually do not offer an extra honours year but may award a bachelor's degree with honours on the basis of performance and/or with some additional work requirements taken concurrently. This pattern is especially common in Bachelor of Engineering and Bachelor of Laws.

There are special cases of honours - for example, extra years in some of the longer professional bachelor's degrees. The Bachelor of Medical Science (there are similar degrees in other fields, e.g. Dentistry) is a one-year honours-like year that occurs after three of the medical bachelor's degree but which results in the award of the B.Med.Sci. as a separate degree.

Double or Combined Degrees

Bachelor's degrees can be taken in combination, for example Bachelor of Laws and Bachelor of Arts (L.L.B./B.A.). With cross credits, these double degrees usually only take one additional year. The L.L.B./B.A. is usually a five-year degree.

Cross faculty combined degrees are also available, where unlike double degrees, the award is only one degree but combines the content of two faculty's degrees. The Bachelor of Science in Engineering (B.Sc.Eng., a five-year degree is an example).

Graduate Certificates and Graduate Diplomas

Graduate Certificates and Graduate Diplomas are generally designed for specific vocational purposes, either the broadening of skills and knowledge already gained in an undergraduate program, or vocational skills and knowledge in a new professional area. Graduate Certificates are usually six months full-time and Graduate Diplomas 12 months full-time, typically following a Bachelor's degree although entry is possible based on recognition of other forms of prior learning. They can be both an exit qualification in their own right or steps on the way to a Master's degree.

In special cases, the graduate diploma is one of the required professional qualifications for entry to a certain profession. The [Graduate] Diploma of Education (G.Dip.Ed. or Dip.Ed.) is the best example.

Master's Degrees

The AQF describes a graduate of a Master's degree program as being able to:

- 'provide appropriate evidence of advanced knowledge about a specialist body of theoretical and applied topics;
- demonstrate a high order of skill in analysis, critical evaluation and/or professional application through the planning and execution of project work or a piece of scholarship or research; and
- demonstrate creativity and flexibility in the application of knowledge and skills to new situations, to solve complex problems and to think rigorously and independently.'

There are two main types of Master's degrees:

- **A master's degree by research and thesis and some course work.** Typically, the research and thesis represents a minimum of two-thirds of the degree work. Entry can be from a Bachelor Honours degree or Master's preliminary year, a research-based Graduate Diploma or equivalent research experience.
- **A master's degree by coursework** consists of at least two-thirds of coursework with a smaller research project and thesis. Entry may be from a Bachelor's degree, a Bachelor's Honours degree or a Graduate Diploma. Coursework Master's degrees are often structured in a three- to four-semester-nested arrangement with the Graduate Certificate (one semester) Graduate Diploma (a further semester) and Master's degree (a further two semesters);

Some universities also offer a 'Professional' Master's degree involving a work-based project, specifically designed for entry on the basis of a relevant qualification and professional experience or extensive relevant professional experience.

Although there are various pathways as noted above, most Master's degrees require the equivalent of two years of study beyond a three-year Bachelor's degree or one year of study beyond a Bachelor's Honours degree or a four-year (or longer) Bachelor's degree.

Doctoral

The Doctor of Philosophy (Ph.D.) is the most common Doctorate in Australia. Although Ph.D. candidates are often required to complete some coursework, the degree is awarded on the basis of thesis only. Entry is through a Master's by Research degree or honours - a First Class (I) or an upper division Second Class (IIA). The duration is based on the time the research takes to complete and the thesis written. It is nominally three years but is more typically three and a half or four years.

The Professional Doctorate is usually entered from a combined research and coursework Master's degree, a Bachelor's Honours degree (First or Second Class, upper division) or equivalent and requires significant professional practice either prior to and/or as part of the programme, which may be undertaken through varying combinations of coursework and research.

There is a further type of doctoral degree, the higher doctorate, which is awarded to candidates on the basis of an internationally recognised original contribution to knowledge rather than supervised candidature.

The AQF describes the characteristics of learning outcomes at this level to:

'include a substantial original contribution to knowledge in the form of new knowledge or significant and original adaptation, application and interpretation of existing knowledge. These characteristics of learning outcomes may be based on a comprehensive and searching review of the literature, experimentation, creative work with exegesis or other systematic approach or may be based on advanced, searching and expansive critical reflection on professional theory and practice.'

It also describes a graduate of a Doctoral degree program as being able to:

'carry out an original research project, or a project(s) addressing a matter of substance concerning practice in a profession at a high level of originality and quality; and present a substantial and well-ordered dissertation, non-print thesis or portfolio, for submission to external examination against international standards.'

Other

Higher Doctorates such as Doctor of Letters (D.Litt.), Doctor of Science (D.Sc.) and Doctor of Laws (L.L.D.) are awarded on the basis of published and unpublished work of great significance. The body of research is usually collected and is examined by peers before the award is recommended. Such Higher Doctorates should not be confused with honorary degrees awarded on the basis of broad contributions to society.

5. STUDY PROGRAMMES

5.1 Credit System

Australian university programmes are by semesters but there is no uniform credit hours or credit points system so it is difficult to describe standard study programmes. As noted above, there are Bachelor's degrees of different lengths. The use of 'year' is universally equated to two semesters, but some universities offer a third 'semester' which allows students to complete a programme in an accelerated time.

For Bachelor's degrees it is possible to identify two general patterns as follows.

The generalist degree (B.A., B.Sc., B.Ec., etc.) would follow the following pattern:

Semesters 1 and 2 - 4 units (courses/subjects) of equal weight of 0.25 of a full-time semester.

Semesters 3 and 4 - 3 units of equal weight, each 0.33 of a full-time semester.

Semesters 5 and 6 - 2 units of equal weight (0.5) or one double unit (1.0).

The professional degree would have the same structure in each of its semesters, where every unit would be of weight 0.25 of a full-time semester. The units would consist of compulsory units (the majority), optional units chosen from a restricted list, and units selected from other Faculties.

5.2 Grading Systems

Grading systems for individual units in universities are not uniform, although two general patterns exist:

- Letter grades (A through F);
- Descriptive grades (High Distinction, Distinction, Credit, Pass, Fail).

However most transcripts of records provide a per centage mark as well as a grade, or a key to mark equivalents of the letter grades used.

As noted above, a credit hours system does not exist across universities. However, all units have a 'weight', which is a fraction of a full-time equivalent, and so provides a proxy for credit hours. The unit weight is universal because it forms the basis of the system of government funding for universities.

For degrees, most are ungraded with the major exception being the Bachelor's degree with honours. The Honours Bachelor Degree is awarded as: First Class, Second Class (Upper Division or Lower Division), and Third Class. These are usually abbreviated to Class I, IIA, IIB, III.

Some universities award Master's degrees 'with honours'.

6. ADMISSION REQUIREMENTS

Admission to higher education for school-leavers is based on the completion of secondary education at the highest level (year 12), and on performance in year 12 (in some states years 11 and 12) including state-wide examinations. These examinations are subject-based and examine student's achievements in the curricula of year 12 subjects.

Given the State responsibility for secondary education, there is no single Australian system. However, a 13-year school system is normal (despite the common use of 'year 12' for the final year), comprising a preparatory year (entry at age 5) followed by 12 years of a mix of primary school (year 1 to 6 or 1 to 7) and secondary school either six years (years 7 to 12) or 5 years (years 8 to 12). In some States/Territories the final two years of secondary education exist in separate schools (secondary colleges).

Up to 25 per cent of students attend private schools, which follow similar patterns to and follow the same curricula as the government schools.

For admission to undergraduate higher education, school-leavers are given a tertiary admissions score or rank based on the public examinations results, sometimes combined with school assessments. In some States/Territories the Australian Scholastic Aptitude Test is used to moderate scores across subjects and/or schools. The system for calculating the score is different in each State/Territory and has a range of names (e.g. tertiary admissions score). There is a national table of equivalency between the scores/ranks so that students can seek entry nationally.

Students are eligible for admission if they pass a specified set of year 12 subjects, but whether they obtain a place and in which field depends on competition for place based on their tertiary admissions score.

In the larger States a central admissions centre coordinates applications to higher education (and to technical and further education in some cases). Normal admission is based on the tertiary admission score and a student's nominated preferences for specific programmes in specific universities. Demand is higher than supply, so that entry levels for specific programmes in specific universities vary from year to year. There is always an unmet demand.

There are various pathways for those who have not completed year 12 to enter universities. These include credit transfers from TAFE, adult entry schemes and bridging programmes. Open Learning Australia (OLA) is also used as an entry pathway. OLA has no entry requirements. Once students successfully complete a number of university units through OLA, they can apply directly to a university for entry.

Admissions to [post] graduate programs are administered by the individual universities. The qualification requirements are discussed above in the section describing Graduate certificates, Graduate diplomas, Master's degrees and Doctoral degrees.

7. DEGREE CONFERRING AGENCIES

Degrees and diplomas are awarded by the individual universities under the authority of the Council or Senate, which obtains its authority from the Act of Parliament establishing the university. The Faculties or Schools certify to the Chancellor (the chair of the Council or Senate) that the candidates have met the conditions for the award of the specific degree or diploma as approved by the Council.

The use of the title 'University' requires an Act of Parliament, either State or Territory, depending on the location of the university. However, as noted earlier, institutions (non-self-accrediting institutions) that are not universities can award degrees after accreditation by State authorities.

In addition, the Australian Vice Chancellors Committee (AVCC) has developed a set of criteria for a university to be recognised by the AVCC for membership.

8. ASSESSMENT OF HIGHER EDUCATION INSTITUTIONS AND ACCREDITATION

Although universities are self-accrediting, all have rigorous procedures supervised by their Council. The Council/Senate is independent and has appointees representing various community groups and the State/Territory within which the universities are established by Act of Parliament. As noted earlier, the State/Territories have ministers responsible for higher education in their state and officers of higher education.

The Federal government, through DEST, published regular reports on the performance of universities⁶. These reports provide detailed statistics for each of the public universities.

Quality assurance is now conducted by the Australian Universities Quality Agency (AUQA) which was established by MCEETYA in 2000 replacing a previous quality assurance process. AUQA is in the process of its first round of quality audits of Australian universities over a three-year period. AUQA's audit reports on each university are public documents. The reports can be accessed on AUQA's website⁷.

Professional bodies accredit courses leading to membership. The procedures of these bodies are rigorous and the reports are public.

There are private organisations that produce consumer guides to universities and their courses. The best known and most respected are The Good Universities Guide published by Hobsons Australia Pty. Ltd. There are undergraduate and graduate editions.

9. DEGREES AND PROFESSIONAL COMPETENCE

The requirements for professional practice in Australia fall into two main approaches.

One approach is, the membership is achieved by completing a degree that has been accredited by the relevant professional body. Engineering is an example. The Institute of Engineering Australia (IEAUST) has a detailed and stringent accreditation process for degrees in professional engineering. Graduates of these degrees apply to IEAUST for membership on the basis of their degree. Teaching is similar, except that each State has its own teacher registration board and their requirements of the accredited degrees are not necessarily identical. A graduate applies for accreditation to teach in a particular State based on his/her degree.

The other approach is where membership is based on completing an accredited degree and on some further training or practical experience. In medicine, the courses are accredited by the Australian Medical Council. In addition, the graduate has to complete an approved period of internship. If a graduate from an accredited law degree wishes to practice as a lawyer, they need to have completed 'articles' (a period of supervised practice) or have completed a special course. Like teaching, the professional bodies are State-based rather than national.

10. INTERNATIONAL RECOGNITION OF DEGREES

A government agency, the National Office of Overseas Skills Recognition (NOOSR), established in 1989, is the national expert and co-ordinating body on overseas skills assessments and recognition. Its mission is 'to help the overseas-trained to work and study in Australia by providing information, advice and assistance in relation to the recognition of overseas qualifications and skills, and to encourage improved international arrangements for the recognition of qualifications and skills'. And its principal functions 'include provision of assessment services, information, advice and promotion of fair, equitable and transparent assessment of qualifications'.

⁶ For example, *Characteristics and Performance Indicators of Australian Higher Education Institutions 2000*, Canberra: DEST, 2002. Available on the website www.dest.gov.au/highered/pubgen/pubsalph.htm

⁷ www.auqa.edu.au/qualityaudit/aa_reports/index.shtml

NOOSR produces a set of *Country Education Profiles*, which describes the education systems of over 90 countries and provide guidelines on the assessment of educational awards from these countries. They are an excellent guide to a graduate from a foreign university to know if their qualifications will be recognised or to assess what amount of credit is likely to be provided. NOOSR provides an application process for any individual to have his/her qualifications and/or skills assessed. The Country Education Profiles can be purchased individually or as a set and are available in Australian Embassies and diplomatic offices in most countries.

In addition NOOSR provides published frameworks and guides to assist others who are involved in assessing qualifications. An example is the provision of ‘Guiding Principles for the Assessment and Recognition of Overseas Skills and Qualifications’ in a publication *Best Practice Guide for Professional Bodies*.

Australia is a signatory to the UNESCO Regional Convention on the Recognition of Studies, Degrees and Diplomas in Higher Education in Asia and Pacific, and the Lisbon Convention on the Recognition of Qualifications Concerning Higher Education in the European Region. It has a large number of bilateral MOUs, which include agreements on recognition of educational qualifications.

BRUNEI DARUSSALAM

Diana P.P. Cheong

1. COUNTRY PROFILE

Brunei Darussalam is situated in the northwestern coast of Borneo and covers a land area of 5,765 square kilometres. It has a population of nearly 400,000 comprising two-thirds Malay and the rest, other indigenous people, Chinese and expatriates. According to 1994 population figures, 61 per cent of Brunei's population is under the age of 30 years while only 6.6 per cent is above 55 years of age.

Brunei Darussalam was a British protectorate from 1906 to 1983 during which time it was known simply as Brunei. In 1984, when it gained full independence the longer name was adopted and it means 'Abode of Peace'. Although Brunei Darussalam still holds close links with Britain (for example in the educational arena), politically, it is a sovereign, democratic Malay Muslim Monarchy. At present the government consists of 12 ministries. The appointment of ministers and the creation of new ministries are directly controlled by the Head of State, His Majesty the Sultan and Yang DiPertuan of Brunei Darussalam, Sultan Haji Hassanal Bolkiah Mu'izzadin Wadaullah.

The monarchy has throughout documented history being the main system of government of Brunei and Islam has been the dominant and official religion of Brunei from as early as the 13th century. Consistent with such a background then, the state's national philosophy is the Melayu Islam Beraja (MIB) or Malay Islamic Monarchy. The MIB integrates the language and culture of Malay with Islamic laws and values and the monarchical system of government as the way of life for Bruneians.

While Brunei is a small country in terms of area and population, it is well endowed with oil and gas reserves. One of the results of this is that Bruneians enjoy a standard of living which is at least comparable with newly-industrialised countries within the ASEAN region. In order to decrease its reliance on oil and gas revenues however, the government is taking policy measures which emphasize the diversification of the economy through the development of agriculture and industry. As a newly-developing country with a small population, Brunei still lacks necessary manpower at all levels. The acceleration of human resources development is therefore given a top priority in national development planning. Currently, only slightly more than 50 per cent of the employed labour are locals and the others are expatriates.

2. NATIONAL EDUCATION SYSTEM

There is no compulsory education in Brunei Darussalam but education is universal and free for all its citizens. Because of its emphasis on human resource development, a substantial allocation of the national budget is devoted to Brunei's education system.

All citizens from the age of five are offered free government schooling. Tuition, textbooks, food, transport where necessary and accommodation in hostels for students from rural

areas are provided free to all pupils. Non-citizens who attend government schools are charged a nominal fee for secondary tuition and the State also subsidizes a number of non-government schools.

Further and higher education is provided for those who are academically eligible and pursuing relevant subject areas; in the light of the national needs. Students are also sponsored by the state to study overseas if studies concerned are not available locally. However, especially since the attainment of independence, a number of tertiary institutions have been established to meet middle-to high-level manpower requirements. These include on the one hand, Universiti Brunei Darussalam (UBD) which provides mainly for degree and postgraduate degree programmes and on the other hand, various technical and vocational institutions (TVE) which offers mainly certificate and diploma programmes which have been validated by the Brunei Darussalam technical and vocational Council. A list of TVE institutions within the country is provided in Annex 1.

The government of Brunei Darussalam views education as a continuing endeavour to develop the all-round potential of the individual. The system is designed to bring into being, an educated and dynamic citizenry whose virtues are complementary to the needs of the modern Islamic State.

The main aims of the national education policy are:

- to foster the all-round development of each individual from the physical, mental and spiritual point of view and in terms of aesthetic disposition in order to make him or her into a Brunei citizen who will uphold the aspirations of the State;
- to inculcate the teaching of Islam so that each individual will honour and be faithful to the Islamic religion and live according to its tenets;
- to cultivate in each individual a sense of loyalty to the Monarch, the State and the Law and an awareness of responsibility as a citizen as well as the obligation to act upon that responsibility;
- to cultivate in each individual the values and cultural norms of Brunei society, centred on the principle of a Malay Islamic Monarchy.
- to instill a love of peace, harmony and mutual help and unity among the citizens and residents of the country;
- to mould in each individual the desire for progress; confidence in one's own ability; creativity; innovativeness; and sensitivity to contemporary change in the interests of adaptation to the demands of the age, though consistent with the cultural values, ethics and goals of the State; and
- to speed up development of manpower resources which are capable, rational and responsible, so that people can improve their standard of life and make a contribution to the development of the country.

(Source: Education in Brunei Darussalam (1992). Government Report).

With the exception of religious and Arabic schools, an agricultural training centre and an arts and handicraft training centre, all government schools and colleges are administered by the Ministry of Education. Non-government schools which consists primarily of mission and vernacular schools are administered by private bodies but are also under the supervision of the

Ministry of Education. In terms of medium of instruction, Brunei Darussalam adopts a bilingual education policy which is a means of ensuring the sovereignty of the Malay Language, while at the same time recognizing the importance of English. In practice, school subjects which are heavily dependent on the English language are taught in English, and others in the Malay language. Similarly at the higher education level, while the majority of programmes are taught in the English medium, there are also programmes which are conducted wholly in the Malay medium (and also, the Arabic medium). The latter includes programmes which are not dependent upon English, such as History, Brunei Studies and Islamic Studies. Through such a policy it is hoped that a high degree of proficiency in both languages will be achieved.

All children entering the government school system at the age of five, stay at the pre-school level for one year before proceeding to the first year of the primary school. They will stay at the primary level for six years. (Primary 1 to Primary 6). At the end of the primary level, pupils are required to sit for a public examination, the Primary Certificate of Examination (PCE.) before proceeding to the secondary level. The secondary level consists of seven to eight years (Form 1 to Form 5 and two years of Pre-University secondary education). There are three public examinations in the secondary level. These are:

- (a) The Penilaian Menengah Bawah or Lower Secondary Assessment Examination (LSAE) which is at which is sat at the end of Form 3.

Further and higher education is provided for those who are academically eligible and pursuing relevant subject areas; in the light of the national needs. Students are also sponsored by the state to study overseas if studies concerned are not available locally. However, especially since the attainment of independence, a number of tertiary institutions have been established to meet middle-to high-level manpower requirements. These include on the one hand, Universiti Brunei Darussalam (UBD) which provides mainly for degree and postgraduate degree programmes and on the other hand, various technical and vocational institutions (TVE) which offers mainly certificate and diploma programmes which have

- (b) The Brunei Cambridge General Certificate of Education (BCGCE) 'O' levels or the GCE 'N' level which is usually sat at the end of Form 5.
- (c) The Brunei Cambridge General Certificate of Education (BCGCE) 'A' levels which is usually sat at the end of Form 6.

In order to cater for different levels of learning abilities, upper secondary students are streamed into two general categories, depending on their LSAE results. Those who do well will continue to with upper secondary studies (Form 4 and Form 5) before sitting for their BCGCE 'O' levels. For those who pass their LSAE but have only achieved a lower grade but wishes to complete secondary schooling, there is an alternative GCE 'N' level route. 'N' level or 'Normal' level entitles a student to sit for the BCGCE 'O' levels if they pass the 'N' level exam which is a two-year programme. Compared to the earlier category, students following the 'N' level will take a longer period; three years in total, before sitting for their BCGCE 'O' level. Whilst following the British system, both BCGCE 'O' and 'A' levels have been adapted toward the Bruneian context.

Not all students proceed to complete the secondary level (Figure 1). Some may pursue instead, vocational schooling which provides two years full-time education to students with Form 3 levels of attainment. Vocational schooling offers a comprehensive range of craft-level programmes in modular form and it is designed to produce skilled graduates who can take up employment directly, or who wish to progress to higher craft or technical programmes at TVE institutions.

In summary, at the end of Form 3, students have the following options:

- to pursue two or three years upper secondary culminating in the BCGCE 'O' levels or GCE 'N' level and having achieved adequate results to choose to complete their BCGCE 'A' levels which will make them eligible to pursue university or other high level TVE programmes; or
- to pursue TVE directly, from vocational schooling and if desired, to a TVE institution. The lower types of TVE institutions, so called 'technical colleges', offer one or two years craft and other vocational courses producing the UK collaborated BTEC type of Ordinary National Certificates (ONC) and the higher level TVE institutions, include a Nursing college which awards a Diploma in Nursing, an Agricultural college for a National Diploma in Agriculture and the Institute Teknologi Brunei (ITB) which is geared at producing BTEC Higher National Diploma (HND) and Higher National Certificate (HNC) graduates.

3. HIGHER EDUCATION SYSTEM

3.1 *Types of higher education system*

As previously stated, in particular from Form 3, post-secondary education consists of a number of educational options, most of which offer varying levels and types of certificates, diplomas and degrees. Although hierarchical distinctions of types of post-secondary education may seem arbitrary, by the very nature and structure of courses offered within each tertiary institution, it would seem more useful to consider the university system of UBD as the main higher education system of Brunei Darussalam.

The university is the only institution offering a wide range of 'degree' level programmes and the certificates and diplomas offered by other named institutions (i.e., primarily synonymous with TVE institutions) are generally of a lower level to those offered at UBD. Top of the TVE institution ranking are BTEC HND or BTEC HNC programmes offered by ITB and these qualifications may only normally entitle entry into the second year (at the maximum) of the University programme. ITB however has started to offer an undergraduate degree level programme in Civil Engineering under a twinning arrangement with the Queens University of Belfast. As of this year (2003) the Laksamana College of Business has also been established, providing for the first time in Brunei, degree level and professional qualifications in Business related programmes on a private basis.

As the degree programme/s offered by ITB and Laksamana College of business are limited in scale and variety, to date therefore, UBD as a public State University is still the main degree offering institution. Consequent sections, therefore, will focus only on UBD itself.

3.2 *Co-ordination of higher education and institutional governance*

UBD was fully operational in 1985 following His Majesty's 'Titah' or royal command. Although subsumed under the Ministry of Education, following the Constitution of Brunei Darussalam, (order under Section 83) Emergency (Universiti Brunei Darussalam) Order 1988 (University Constitution of 1988), the administration of UBD is quite autonomous from the Ministry of Education. This is not to say that there are no links with the Ministry. Administratively, UBD is self-governing and it follows organizational structures that are commonly adopted by universities

in the Commonwealth, where the Vice-Chancellor is the principal executive and academic officer of the university. The Chancellor of the University is His Majesty the Sultan and Yang DiPertuan of Brunei Darussalam. There are two main bodies in university governance; the University Council and the Senate.

The University Council is the executive body and consequently, the main governing body of UBD. Following the University Constitution of 1988, the University Council shall consist of:

- a chairman,
- the Vice-Chancellor,
- three persons appointed by His Majesty the Sultan and Yang Di Pertuan on the advice of the Vice-Chancellor,
- one person elected by the Senate,
- the permanent Secretary of the Ministry of Finance and the Ministry of Education,
- the Attorney General,
- the Director of Public Services Department,
- a representative of the Guild of Graduates of UBD who is not a full-time staff member of the University, and
- the Registrar and Secretary as Secretary.

There are various standing committees on all policy areas of university governance and administration (e.g. finance, personnel and selection) which report to the University Council. In the area of day-to-day general administration; however, the Vice Chancellor is supported by a full-time internal university administration, the most senior of which is the Registrar and Secretary. Being a small university, the Bursary is a function within the Registry. The Deputy Registrar is the other senior position within the Registry.

Subordinate to the University Council, the Senate is, however, effectively responsible for all academic matters such as the control and general direction of instruction, research and examination, and, the award of degrees, diplomas and certificates. Following the University Constitution of 1988, the Senate shall consist of:

- the Vice Chancellor (chairman)
- the Deputy Vice-Chancellor
- the Heads of institutions
- the Heads of teaching departments (Deans and Heads of Departments)
- the Professors of the University but not including visiting professors
- the Registrar and Secretary as Secretary

Figure 1. Structure of the School System
Ministry of Education



(Source: adapted from 'Education in Brunei Darussalam' (1990) Government)

4. CHARACTERISTICS OF DEGREES AND DIPLOMAS

4.1 Types of degrees and diplomas

There are seven faculties at UBD: Arts and Social Sciences, Business, Economics and Policy Studies, Science, Education, Islamic Studies, Brunei Studies and Medicine. The various undergraduate (Honours) degree programmes with examples of their abbreviations are as follows (under general headings).

Programme	Abbreviation	Content
<i>Malay/Arabic Medium</i> (1) Bachelor of Arts Education	B.A. Pend.	Major in Malay Language, Malay Literature or Islamic Studies Minor in Malay Language, Malay Literature, History, Islamic Studies or Brunei Studies.
(2) Bachelor	B.A.	(a) Brunei Studies (b) Arabic Language (c) Usuluddin (d) Shariah
<i>English Medium</i> (3) Bachelor of Arts Education	B.A.Ed.	(a) Major in Geography, Economics, History or TESL (Teaching English as a Second Language) and; Minor in Geography, Economics, History or Mathematics or TESL. (b) Islamic Studies
(4) Bachelor of Science Education	B.Sc.Ed.	(a) Major and Minor chosen from Biology, Chemistry, Physics and Mathematics
(5) Bachelor of Arts Primary Education	B.A.Pr.Ed.	
(6) Bachelor of Arts	(a) B.B.A. (b) + (c) + (d) B.A.	(a) Business Administration or (b) Public Policy and Administration or; (c) Economics or; (d) Geography, History, Malay Language and Linguistics, Malay Literature and Sociology.
(7) Bachelor of Science	B.Sc.	(a) Mathematics with an option to transfer to B.Sc. Programme in Computer Science at Strathclyde University or another university if qualified. (b) Biological Science. (c) Biotechnology a twinning programme with the University Windsor. (d) Computer Science - joint degree programme with University of Strathclyde, U.K. (e) Electrical and Electronic Engineering-joint degree programme with University of Glasgow, U.K.
(8) Bachelor of Arts	B.Biomedical Sc.	(a) Biomedical Science a twinning programme with the University of Queensland and University of Calgary.
(9) Bachelor of Commerce	B.Com.	(a) Accounting - joint degree program with University of Birmingham.

Postgraduate degree programmes, Master's and Doctoral levels offered by the University are as follows:

Masters programmes:

English medium

M.Ed. in Educational Management

M.Ed. in Language Education

M.Ed. in Social Sciences Education

M.Ed. in Mathematics Education

M.Ed. in Science Education

M.A. in Applied Linguistics

M.A. in Economics

M.A. in Geography

M.A. in History

M.A. in Sociology

M.A. in Anthropology

Master of Public Policy (M.P.P.)

Master of Business Administration (M.B.A.)

MSc in Petroleum Geoscience

MSc in Primary Health Care

MSc in Biology

MSc in Chemistry

MSc in Mathematics

MSc in Physics

Malay medium:

Master of Syariah

Master of Usuluddin

Master of Arabic Language

MA in Malay Language and Linguistics

MA in Malay Literature

Arabic medium:

M.Ed. in Islamic Studies Education

M.Ed. in Language Education

M.Ed. in Malay Language and Linguistics

Doctoral programmes offered by all departments at the following faculties:

Sultan Hassanal Bolkiah Institute of Education

Faculty of Arts and Social Sciences

Faculty of Science

Postgraduate diploma and certificate programmes offered by the University:

Postgraduate Diploma in Counselling for Teachers/Education Officers

Postgraduate Diploma in Counselling for Non-Teachers/Non-Education Officers

Postgraduate Certificate in Technical Education

Postgraduate Certificate in Education for Secondary Schools

Postgraduate Certificate in Education in Teaching Arabic as a Second Language

Postgraduate Diploma in Islamic Law and Legal Practice

Postgraduate Certificate in Education for Religious Secondary Schools

Postgraduate Certificate in Education for Secondary Schools

Pre-degree Diploma and Certificate programmes offered by the University are as follows:

Diploma in Primary Education
 Certificate in Lower Secondary Science Education
 Certificate in Counselling for Teachers/Education Officers
 Certificate in Counselling for Non-Teachers/Non-Education Officers
 Certificate in Special Education
 Certificate in English Language Teaching
 Certificate in Technical Education
 Certificate in Creative Writing
 Certificate in Teaching Malay Language
 Certificate in Educational Management
 Certificate in Early Childhood Education
 Certificate in Special Education

4.2 Information contained in the document

There is no standardized information on documents certifying the receipt of various types of certificates and diplomas but information contained in undergraduate degree programmes are normally as follows:

- title of award
- class of award
- field of study
- awarding institution
- translation (Malay into English)
- signature of the Registrar and Secretary

5. STUDY PROGRAMMES

5.1 Sequence and duration of study

The University operates on a semester system. There are two semesters in an academic year, each made up of 14 teaching weeks and a further one week break in the middle, one week for revision and two weeks for examinations. For each separate course, students will normally attend at least one tutorial hour (not more than eight students per group) and two lecture hours a week.

First Degrees

The minimum period of study for a first degree (B.A.) graduation is normally four full-time academic years (8 semesters). First degree programs are conducted on a unit system for which a student has to accumulate a minimum number of credit-units for graduation. The minimum number of credit-units to be accumulated for first degree programmes is 124 units.

Each degree programme is made up of a number of separate courses in each year and each course carries with it a specified number of credit-units, usually four units. A single credit-unit is usually equivalent to approximately 14 hours of lectures and tutorials in a semester. A practical session or laboratory class is equivalent to one credit unit.

Unless barred by the university on grounds of unsatisfactory attendance at classes or performance in coursework, at the end of each semester every student is required to take the examinations prescribed for the courses taken. If the student passes the examination prescribed for a course he is credited with the credit-unit value assigned to the course. There is a 'supplementary' (re-sit) examination in which a student may be permitted to re-take any course examination that he has failed. A student who fails the supplementary examination must repeat the course if it is a compulsory course.

If a student fails in a compulsory course, he is required to repeat that course in the following semester or academic year, depending on when the course is offered. Similarly, the student will be required to repeat a failed elective course or take another elective course in its place. Notwithstanding this, he/she can proceed to some courses prescribed for the following semester provided that the total number of credit-unit courses taken does not exceed the maximum allowed for that particular semester.

A student may repeat a failed course beyond the minimum period of four years for graduation so as to make up for the required minimum number of credit-units for graduation provided he does not go beyond the prescribed maximum period of six years.

Other programmes

Ph.D. programmes are primarily research-based and would normally be three or four years in duration. Certificate and diploma courses are primarily by coursework and would normally be one or two years in duration.

The sequence and duration of Masters programmes being more varied is provided in details as follows.

Programme	Duration	Level	Assessment
English Medium			
1. M.Ed. in Educational Management	2 years (part-time)	Postgraduate	Coursework and dissertation or project or practicum
2. M.Ed. in Language Education	2 years	Postgraduate	Coursework and dissertation or project or practicum
3. M.Ed. in Social Sciences Education	2 years	Postgraduate	Coursework and dissertation or project
4. M.Ed. in Mathematics Education	2 years	Postgraduate	Coursework and Dissertation or project
5. M.Ed. in Science Education	2 years	Post-graduate	Coursework and dissertations or project
6. M.A. in Applied Linguistics	1 year	Postgraduate	Coursework and dissertation
7. Master of Public Policy (M.P.P.)	1 year	Postgraduate	Coursework and project
8. Master of Business Administration (M.B.A.)	1 year	Postgraduate	Coursework and project
9. M.Sc. in Petroleum Geoscience	1 year	Postgraduate	Coursework and project
10. M.Sc. in Primary Health Care	1 year	Postgraduate	Dissertation only or Coursework and dissertation
11. M.Sc. in Biology	1 year	Postgraduate	Dissertation only
12. M.Sc. in Chemistry	1 year	Postgraduate	Dissertation only
13. M.Sc. in Mathematics	1 year	Postgraduate	Dissertation only
14. M.Sc. in Physics	1 year	Postgraduate	Dissertation only
15. M.A. in English Language and Linguistics	1-2 years	Postgraduate	Dissertation only or Coursework and dissertations
16. M.A. in Economics	1-2 years	Postgraduate	Dissertation only
17. M.A. in Geography	1-2 years	Postgraduate	Dissertation only
18. M.A. in History	1-2 years	Postgraduate	Dissertation only
19. M.A. in Sociology	1-2 years	Postgraduate	Dissertation only
20. M.A. in Anthropology	1-2 years	Postgraduate	Dissertation only
21. M.A. in Brunei Studies	1-2 years	Postgraduate	Dissertation only
Arabic Medium			
1. M.A. in Shari'ah	1 year	Postgraduate	Coursework and dissertation
2. M.A. in Usuluddin	1 year	Postgraduate	Coursework and dissertation
3. M.A. in Arabic Language	1 year	Postgraduate	Coursework and dissertation
Malay Medium			
1. M.Ed. in Islamic Studies Education by	1 year	Postgraduate	Coursework and dissertation or project
2. M.Ed. in Language Education	1 year	Postgraduate	Coursework and practicum or dissertation or project
3. M.A. in Malay Language and Linguistics	1 year	Postgraduate	Dissertation only or Coursework and dissertation
4. M.A. in Malay Literature	1 year	Postgraduate	Dissertation only or coursework and dissertation

* 1st certificate refers to those which are of pre-undergraduate degree level.

* coursework refers to taught courses

* dissertation project and case study refers to research based courses

5.2 *Practical experience*

A number of programmes, in particular teacher training certificates and postgraduate certificates in education require prior occupational (teaching) experience. A number of programmes also emphasize work attachments which is taken during a semester or during holidays. Other than the highly ‘practical’ nature of teacher training and science programmes, there is for example, a one-month work attachment option within the B.A. Business Administration and B.A. Public Policy and Administration programmes which is taken during the third year semester break and is equivalent to a 4-unit course.

5.3 *Grading and evaluation*

The cumulative grade point average system for obtaining a degree is not practised at UBD. Most of the first certificates offered at UBD require a student to accumulate 30 units whereas undergraduate students as mentioned are required to accumulate 124 units. The class of an undergraduate degree is determined according to the overall final weighted percentage of course results in all semesters as follows:

Overall Final Weighted Per centage	Class of Degree to be Awarded
80% and above	First Class Honours
70% to 79%	Second Class (Upper) Honours
60% to 69%	Second Class (Lower) Honours
50% to 59%	Third Class Honours
40% to 49%	Pass Degree
39% and below	Fail

Although a normal full-time undergraduate programme is conducted over eight semesters (4 years), upgraders and others offering entry qualifications above ‘A’ levels (HND holders or equivalent), may be granted exemptions and finish their studies in six or seven semesters.

6. ADMISSION REQUIREMENTS

6.1 *Qualification required for admission*

First certificates which are mainly teachers certificates normally require at the minimum, teaching experience since these are intended as upgrading programmes for serving teachers who do not possess an undergraduate degree.

For undergraduate programmes UBD will consider candidates who have the following qualifications:

- General Certificate of Education (GCE) “O” and “A” Levels, or equivalent, at specified grades
- Pass in the university entrance examinations of an accredited university
- Relevant Higher School Certificate
- Other qualifications deemed equivalent to Higher School Certificate/GCE “A” Levels by the University such as a Higher National diploma or the International Baccalaureate
- A high level of English proficiency as demonstrated by one of the following: an “O” Level in English at Grade C, IELTS score of 6.5, or TOEFL score of 550.

For Master's Programmes candidates are expected to have a first degree with good grades in a relevant subject from UBD or an accredited university. In addition, the University will require candidates to exhibit an acceptable level of language proficiency in the language of instruction.

For Ph.D. programmes candidates are expected to have a Master's degree with good grades in a relevant subject from UBD or an accredited university. Candidates may be considered if they possess other academic and/or professional qualifications and experience. In addition, the University will require candidates to exhibit an acceptable level of language proficiency in the language of instruction.

7. DEGREE CONFERRING AGENCIES

UBD itself confers the degrees and certificates and is authorized to do so under the University Constitution of 1988.

8. ASSESSMENT OF HIGHER EDUCATION INSTITUTIONS

At present, an organization responsible for assessment and accreditation is not yet in place but the University ensures that it is comparable to other internationally renowned higher education institutions in particular through the following mechanisms:

- As indicated previously, a number of degree programmes are linked to universities abroad, for example, the joint degree programmes in Engineering, Computer Science, Mathematics and Commerce.
- The University practices a system of involving visiting external examiners for students examination papers and dissertations to ensure quality and to act as moderators.
- There is a 3-yearly assessment of curriculum which includes invited established professors from leading overseas academic institutions.

9. DEGREE AND PROFESSIONAL COMPETENCE

The higher education degree is considered a pre-requisite for professional positions in many fields. The type of qualifications, levels, and licences required for most professions are similar to the U.K. system.

For example:

- In order to be granted a licence to practise as an accountant which is issued by the Ministry of Finance, a person must normally be a certified or chartered accountant which is validated by the UK Board of Certified or Chartered Accountants.
- A lawyer must possess a practising certificate which is issued by the Chief Justice of Brunei on the criteria of having a barrister's or solicitor's qualification which is normally obtained from the UK, Malaysia or Singapore and who has been admitted to the Brunei Bar.

- A teacher normally requires a first degree together with the PGCE (teacher's training certificate).

The public sector accounts for approximately two-thirds of employment in Brunei Darussalam. Employment selection procedures are dealt with by respective ministries but there is a separate government body - the Public Services Commission which regulates standards of practice and eligibility for employment.

10. INTERNATIONAL RECOGNITION OF DIPLOMAS

Because of its international comparability, certificates, diplomas and degrees within Brunei Darussalam are generally recognized by ASEAN countries and abroad. However at present, Brunei Darussalam does not have any official bilateral or multilateral agreements with other countries regarding recognition of degrees and diplomas. Brunei Darussalam is also not a signatory to the UNESCO Regional Convention on the Recognition of Studies, Diplomas and Degrees in Higher Education in Asia and the Pacific.

REFERENCES

- Ministry of Education, 1990 and 1992. *Education in Brunei Darussalam*. Government Report by Public Relations Section.
- Universiti Brunei Darussalam, 1995-96. *Prospectus*. Public Relations Officer, Universiti Brunei Darussalam.
- Universiti Brunei Darussalam, 1995-96. *Faculty Handbook*. Public Relations Officer, Universiti Brunei Darussalam.
- Universiti Brunei Darussalam, 1988. *Constitution of Brunei Darussalam Emergency (Universiti Brunei Darussalam) Order*, Supplement to Government Gazette Part II.
- Janin Erih. *Management of Finance in Universiti Brunei Darussalam*. Presented at the Sub-regional workshop on institutional management in higher education Brunei Darussalam. 10-21 November, 1994.
- Borneo Bulletin Brunei Yearbook, 1996*. Brunei Press Sdn bhd.
- Ministry of Development. *Negara Brunei Darussalam Sixth National Development Plan 1991-95*.

Annex 1**LIST OF TVE INSTITUTIONS**

- (1) Nakhoda Ragam Vocational School
- (2) Sultan Bolkiah Vocational School
- (3) Sinaut Agricultural Centre
- (4) The Mechanical Training Centre
- (5) The Jefri Bolkiah College of Engineering
- (6) Institut Teknologi Brunei
- (7) Sultan Saiful Rijal Technical College
- (8) Sekolah Vokasional Lambak Kanan
- (9) Brunei Arts and Handicraft Training Centre
- (10) Akademi Seniman
- (11) Maktab Jururawat Pengiran Anak Puteri Rashidah Sa'adatul Bolkiah (the PAPRSB Nursing College)
- (12) Brunei Hotel Training School
- (13) Laksamana College of Business

1. COUNTRY PROFILE

The Kingdom of Cambodia covers over 181,035 square kilometres, bordered by the Socialist Republic of Vietnam to the east, by the Gulf of Thailand to the south, by Thailand to the west, and by the Lao People's Democratic Republic to the north. The Country is characterized by:

- two-thirds of the land comprising populous central plains surrounded by sparsely populated highlands with densely forested mountains;
- the Mekong River valley in the East and in Phnom Penh, extending its arm into the Basac River which continues southeastward to lower delta in Vietnam and to the South China Sea;
- the Tonle Sap or the Great Lake dominating the central region which is an extension of the Mekong River to the Northwest with a particular feature as an overflow buffer to the Mekong River system floods and a source of water supply during the dry season;
- the Cardamom and Elephant mountains to the south separating the wet coastal region from the rest of the country.

The climate in Cambodia is tropical monsoon. The dry season is from November to May, the southwest monsoon brings the rainy season from mid-May to early November.

Cambodia is a predominantly rural country with 85 per cent of its approximately 13 million population living in the rural areas. There are approximately more than one million people living in the capital Phnom Penh. The growth rate is estimated at 2.8 per cent. About 95 per cent of the population is of Khmer origin; the rest is made up of ethnic minorities, Chinese and Vietnamese. The population density is estimated at 72 people per square kilometre and 95 per cent of the population observes Theravada Buddhism. This religion is promulgated by the constitution. Khmer is the official language.

Cambodia is an agrarian country. Since 1989, Cambodia has changed its policy to encourage private foreign investment towards a free market economy. The return to the world economy poses a need for intensive capital investment, the restoration to productive use of the people and their land, and a fair distribution in opportunity among all citizens.

2. NATIONAL EDUCATION SYSTEM

Much of the educational infrastructure was destroyed by the war. The constitution of the Kingdom of Cambodia has defined clearly a democratic and pluralistic government structure. Chapter 6 states the rights of all citizens to obtain education. Every citizen has an equal right to obtain equal education at basic levels and the government shall establish a general and universal education system throughout the country. The education principles aim at training people, equitably and according to their capacity, to enable them to earn a living. The new constitution promulgates a compulsory education for nine years and a guaranteed quality education for Cambodians. There is a restructuring of the educational system from 11 years to 12 years of schooling. The Cambodian education system is a complete one, from pre-school (3 years), primary school (6 years), lower secondary school (3 years), upper secondary school (3 years) and tertiary education (4-7 years) as shown in the annexed chart. Vocational and Technical Education and training is conducted from 1 year to 5 years. Non-formal education also contributes to the training of citizens.

The education system is primarily defined by an overall governance structure. The education system is heavily decentralized with three levels of governance responsible for its management. At the central level, the Ministry of Education, Youth and Sports (MOEYS) has overall responsibility for establishing national policies and curriculum guidelines. Some tertiary institutions and vocational and technical secondary education institutions are under the governance of other technical ministries (Ministry of Agriculture, Health, Labor, etc.). The other two levels are the provincial and district administrations. The MOEYS does not only formulate the national policies but also the budget for all provinces, and ensures that all local educational authorities spend their budgets and implement educational development projects within the national policy framework and budget allocation.

All kinds of private schools are allowed to operate according to the curriculum development approved by the Ministry of Education, Youth and Sports.

3. HIGHER EDUCATION SYSTEM

Higher education was one of the areas most severely affected by the events of recent years. Despite an unstable political situation the Cambodian Government throughout the 1980s re-established its institutions of higher education. A network of nine public higher education institutions have been established which provide for instruction in areas such as agriculture, medicine, economics, industry, technology, teacher training, science, art and culture. Nineteen technical and professional training institutions (specialized secondary schools) also offer tertiary level courses lasting for periods of two to four years for upper secondary school graduates.

In addition, there are 21 private universities and institutes that have been established since 1997. The private universities and institutes offer a wide range of courses from Associate degrees to Doctoral degrees. The nine public institutions of higher education are:

- the Royal University of Phnom Penh (RUPP) which was founded in 1960 and was expanded in 1988 by merging the teacher training college (Ecole Normale Supérieure) with the Foreign Language Center and the Central Political School now with 17 departments grouped into two faculties and two institutes: Faculty of Science, Faculty of Humanities and Social Sciences; Institute of Foreign Languages and Institute of Information and Communication.

- the Institute of Technology of Cambodia (ITC), formally the Institut Technique Supérieur de l’Amitié Khmero-Sovietique (Higher Technical Institute of Khmer Soviet Friendship), was reopened in 1981 with the assistance of the former Soviet Union. Since 1993, after the retreat of the Soviet Union, the French Government provided assistance for renovating and developing ITC. The institute has six departments: Civil Engineering, Rural Engineering, Chemical and Agricultural Food Engineering, Electrical and Energy Engineering, Industrial and Mine Engineering and Informatics.
- the University of Health Sciences which provides training for doctors and assistant physicians in Medicine, Pharmacy and Dentistry.
- the Royal University of Agriculture (RUA) which is divided into eight faculties: Faculty of Agronomy, Faculty of Animal Health and Production, Faculty of Agricultural Technology Management, Faculty of Forestry, Faculty of Fishery, Faculty of Agro-Industry, Faculty of Agricultural Economics and Rural Development and Faculty of Land Management and Land Administration.
- the Royal University of Fine Arts composed of five Faculties: Faculty of Archaeology, Faculty of Architecture and Urbanization, Faculty of Plastic Arts, Faculty of Music and Faculty of Choreographic Arts.
- the National Institute of Management made up of seven specializations: Marketing, Accounting, Management, Tourism, Finance and Banking, Eco-Business and Management Information Systems.
- the Royal University of Law and Economic Sciences which offers the fields of Law and Economic Science.
- the Faculty of Pedagogy founded by transforming the former “Ecole Supérieure des Cadres de Gestion de l’Education” providing training to graduates of RUPP, the faculty trains graduates for secondary school teachers.
- the Vedic Maharichi University located in Prey Veng Province, founded in 1993 with the co-operation of the Australian Aid for Cambodian Fund (AACF) with two Faculties: Agriculture and Management.

Types of higher education institutions	Degree programmes	Non-degree programmes
Universities	Ph.D., Master’s , Bachelor’s, Diploma	Associate Degree University Diploma
Institutes	Master’s, Bachelor’s and Diploma of Engineering	University Diploma

3.1 External control of institutions of higher education

Post-secondary and higher education institutions receive their authority to function and to grant degrees from the Council of Ministers. This authority is granted by a sub-decree of the Council of Ministers. Higher education institutions in Cambodia are under the jurisdiction of four Ministries. The Ministry of Education, Youth and Sports controls the Royal University of Phnom Penh, the Institute of Technology of Cambodia, the Vedic Maharishi University, the Royal

University of Law and Economic Sciences, the National Institute of Management and the Faculty of Pedagogy and all private Institutions; the Ministry of Agriculture controls the Royal University of Agriculture; the Ministry of Health controls the University of Health Sciences; and the Ministry of Culture controls the Royal University of Fine Arts. The Ministry of Education, Youth and Sports has overall responsibility for establishing national policies and curriculum guidelines. All public institutions receive financial support from the government. Since 1997, many of them have had other financial sources through fee-paying students.

Since 1993, multilateral co-operation with the French Government was established by the Royal Government of Cambodia in order to renovate and develop the Institute of Technology of Cambodia. A Francophone agency - AUPELF-UREF (Association of universities using partially or entirely French language) assists the Ministry of Education, Youth and Sports in strengthening administrative, pedagogical and financial management of the Institute.

3.2. Internal control and administration of institutions of higher education

Except for the Institute of Technology of Cambodia which is a multilateral cooperation, all institutions of higher education are managed by a director (Rector or Dean) assisted by one or more deputy directors. The ministries concerned delegate the daily administration of the institutions to a rector (for the university) or dean (for the faculty). The rectors or deans have their vice-rectors or deputy deans in charge of academic affairs, planning, research and development. Under this board (of rectors or deans), there are usually departments, offices or desks. For example, the RUPP has 17 departments (Mathematics, Physics, Chemistry, Biology, Computer Science, International Business Management, Geography, History, Philosophy, Literature, Psychology, Sociology, Tourism, Linguistics, Media Communication, Japanese, Environment and Foreign Languages) and four offices (Administration, Finance, Research and Registrar which includes Student Affairs). The Royal University of Agriculture has three desks, Administration and Finance, Education and Research. The Royal University of Law and Economics has three offices: Administration, Education and Research. In numerous institutions, different committees are established to support the management and development of the institutions: Committee for Curriculum Reform, Committee for Strategic Planning, Committee for Master's Studies, Council of Discipline, Council of Pedagogy, Council of Studies and Student Affairs, etc. Student associations also participate in the management and development of the institutions.

The Institute of Technology of Cambodia is an institution operating under multilateral co-operation. Principal internal financial and operational decisions affecting the institute are made by the Council of Administration (Conseil d'Administration). The Council of Administration is composed of representatives from the Cambodian Government, donor countries, employers and the private sector. The Council of Administration elects the President of the Council and delegates the daily administration of the institute to a director. There are three directorates and six

departments in the institute. Each department is supported by a Council of the Department. The Council of Studies and Student Affairs (Conseil des Etudes et de la vie universitaire) supports the management of the Institute. Generally, department members have a significant influence, both directly and indirectly, on the governance of the Institute. They usually participate in this process through the Council of Department, Council of Teachers and Council of Studies and Student Affairs. Students may also have an influence on institutional policy and management through student associations by electing and participating in the Council of Studies and Student Affairs.

The Royal Kret of Accreditation Committee of Cambodia (ACC) was approved on March 31, 2003 by the King. The purpose of this Royal Kret is to determine the organization of structure, roles, functions, and duties regarding the administration of the accreditation process of higher education for all higher education institutions (HEIs), which grant degrees (Bachelor's degree and above) in the Kingdom of Cambodia. ACC has its own secretariat located in the Council of Ministers.

4. CHARACTERISTICS OF DEGREES AND DIPLOMAS

The name of the diploma of higher education has changed many times. Between 1980 and approximately 1993, the degrees conferred upon completion of undergraduate course programmes were all named "Diploma of Higher Education". There are different types and titles of degrees and diplomas delivered by institutions of Higher Education. The following are the titles used in recent years:

- The RUPP grants Master's degrees, Bachelor's degrees and professional diplomas. They are: Master of Tourism, Master of Linguistics, Bachelor of Arts (B.A.) in Sociology, History, Geography, Literature, Psychology, Environment, Media Communication, Linguistics, Bachelor of Science (B.Sc.) in Mathematics, Physics, Chemistry, Biology, Computer Science and International Business Management; Bachelor of Education (B.Ed.) in English, French and Japanese Language Teacher Training, and a collaboration with the Asian Institute of Technology is started, on a Graduate Certificate in Environmental Studies.
- The Institute of Technology of Cambodia grants two types of diplomas: University Diploma of Technology (DUT Diplome Universitaire de Technologie) and Diploma in Engineering (Diplome d'Ingenieur).
- The University of Health Sciences grants the Diploma in Medicine, Diploma in Pharmacy and Diploma in Dentistry.
- The Royal University of Agriculture grants Master of Agriculture, Master of Science and Veterinary Medicine, Bachelor of Agriculture Sciences in Agronomy, Animal Health and Production, Agricultural Technology Management, Forestry, Fishery, Agro-Industry, Agricultural Economics, Rural Development, and Land Management and Land Administration.
- The Royal University of Fine Arts grants a Bachelor of Arts in Archaeology, Plastics, Architecture and Urbanization, Music and Choreography.

- The National Institute of Management grants Master of Business Administration, and Master of Finance, Bachelor of Business Administration (B.B.A.) in Management, Tourism, Accounting, Finance and Banking, Marketing Eco-Business and Management Information Systems.
- The Royal University of Law and Economic Sciences grants different types of diplomas with different titles. They are: Master of Public Administration, Private Law, International Business, Management, Marketing Management, Financial Management, and Tourism; Bachelor of Laws, Economics, Accounting, Economic Information; and Bachelor of Business Administration B.B.A., (in collaboration with AIT, bilingual: French and English); University Diploma in Accounting, Banking; and Diploma in Professional Law.
- The Faculty of Pedagogy grants a postgraduate diploma for upper secondary school teachers.
- The Vedic Maharishi University grants Bachelor's Degrees in Science.

The diploma document mentions the name of the recipient of the degree, his/her birth date, the title of the degree, the field of study and the institution conferring the diploma. Except for the Royal University of Agriculture and Fine Arts, all institutions confer their diplomas countersigned by the Ministry of Education, Youth and Sports.

5. STUDY PROGRAMMES

The study programmes leading to a degree (Bachelor's, Engineering) require at least four years of study. The diversity in the duration of study programmes are shown in the following table.

Study Programmes in Higher Education Institutions

Title	Abbr	Year(s) to Complete*	Practical Experience	Offering Institution
1	2	3	4	5
<ul style="list-style-type: none"> • Master of Tourism • Master of Linguistics 	M.A.	2 Years	6 months	Royal University of Phnom Penh
• Graduate Certificate in Environmental Studies		(Bachelor + 1 year)	5 weeks	
• Bachelor of Science in Natural Sciences	B.S.		2 weeks	
<ul style="list-style-type: none"> • Bachelor of Arts in Social Science, Humanities • Bachelor of Education in English, French, Japanese 	B.A. B.Ed.	4	2 weeks 1 month	
<ul style="list-style-type: none"> • Diploma in Medicine • Diploma in Dentistry • Diploma in Pharmacy 	D.M. D.D. D.P.	7 7 6	64 weeks + 1 year internship 64 weeks + 1 year internship 32 weeks + 9 months internship	University of Health Sciences
<ul style="list-style-type: none"> • Bachelor of Arts (in Architecture) • Bachelor of Arts (in Plastics) 	B.A.	3	8 months 4-7 months	Royal University of Fine Arts
<ul style="list-style-type: none"> • Bachelor of Arts (in Archaeology) • Bachelor of Arts (in Music) • Bachelor of Arts (in Choreographic Arts) 	B.A.	5	4 months 4-7 months 4 months	Royal University of Fine Arts
<ul style="list-style-type: none"> • Master of Public Administration • Master of Private Law • Master of International Business • Master of Management • Master of Marketing Management • Master of Financial Management • Master of Tourism 	M.A. M.A. M.S. M.A. M.S. M.S. M.A.	2 years	6 months	Royal University of Law and Economic Sciences
<ul style="list-style-type: none"> • Bachelor of Laws • Bachelor of Economic • Bachelor of Accounting • Bachelor of Economic Information • Bachelor of Business Administration (Bilingual French and English) 	B.A. B.S. B.S. B.S. B.B.A.	4 4 4 4 (2+) 2	3 months + Report	
<ul style="list-style-type: none"> • University Diploma in Accounting • University Diploma in Banking • Diploma in Professional Law 	D.U.C. D.U.B. D.P.L.	2	2 months	

<ul style="list-style-type: none"> • Master of Agricultural Science • Master of Science and Veterinary Medicine • Master of Renewable Natural Resources • Master of Aquaculture and Aquatic Resource Environment • Master of Agricultural Economic Development 	M.S.	2	6 months	Royal University of Agriculture (RUA)
<ul style="list-style-type: none"> • Bachelor of Agricultural Science in: <ul style="list-style-type: none"> - Agronomy - Animal Health and Production - Agricultural Technology Management - Forestry - Fishery - Agro-Industry - Agricultural Economics - Rural Development - Land Management and Land Administration 	B.S.	4	6 months	Royal University of Agriculture (RUA)
<ul style="list-style-type: none"> • Bachelor of Science in: <ul style="list-style-type: none"> - Agriculture - Management 	B.S.	4	10 weeks	Vedic Mahabishi University
<ul style="list-style-type: none"> • Diploma of Engineering in: <ul style="list-style-type: none"> -Electrical and Energy Engineering -Civil Engineering -Rural Engineering -Chemical and Agricultural Food Engineering -Industrial and Mining Engineering -Informatics 	D.I.G.E.E. D.I.G.C.I. D.I.G.R.U. D.I.G.C.A. D.I.G.I.M. D. I.	5	8 months + project report	Institute of Technology of Cambodia (ITC)
<ul style="list-style-type: none"> • Master of Business Administration • Master of Finance 	M.B.A. M.S.	2 years	6 months	National Institute of Management
<ul style="list-style-type: none"> • Bachelor of Business Administration in : <ul style="list-style-type: none"> -Management -Marketing -Accounting -Finance and Banking -Tourism -Eco-Business and Management Information System 	B.B.A.	4	6 months	
<ul style="list-style-type: none"> • Diploma in Upper Secondary Teaching 		(Bachelor +1 year)	4 weeks	Faculty of Pedagogy

Examples of study programmes in some private institutions are the following:

Title	Abbr.	Year(s)to complete*	Research Study + Research Paper	Offering Institution	
1	2	3	4	5	
<ul style="list-style-type: none"> • Ph.D. in Education • Ph.D. in Political Science 	<ul style="list-style-type: none"> Ph.D. Ph.D. 	3	2 years	Chamroeun Polytechnic University	
<ul style="list-style-type: none"> • Master of Education • Master of Business Administration 	<ul style="list-style-type: none"> M.Ed M.B.A. 	2	6 months		
<ul style="list-style-type: none"> • Master of Agriculture and Rural Development 	M.S.	2			
<ul style="list-style-type: none"> • Master of Law 	M.A.	2			
<ul style="list-style-type: none"> • Master of Political Science 	M.A.	2			
<ul style="list-style-type: none"> • Master of Tourism Management and Hotel 	M.A.	2			
<ul style="list-style-type: none"> • Bachelor of Computer Science • Bachelor of Economics • Bachelor of Business • Bachelor of Laws • Bachelor of Education • Bachelor of Rural Agriculture Development 	<ul style="list-style-type: none"> B.S. B.S. B.S. B.A. B.A. B.S. 	4			6 months
<ul style="list-style-type: none"> • Master of Business Administration • Master of Development Management • Master of Computer Information Management 	<ul style="list-style-type: none"> M.B.A. M.D.M. M.S. 	2	6 months		Norton University
<ul style="list-style-type: none"> • Bachelor of Business Administration • Bachelor of Economic Science • Bachelor of Arts in Tourism • Bachelor of Arts in English 	<ul style="list-style-type: none"> B.B.A. B.S. B.A. B.A. 	4	6 months		Norton University
<ul style="list-style-type: none"> • Master of Legal Literature • Master of Business Administration • Master of Information Technology • Master of Computer Applications • Master of Law and Political Science 	<ul style="list-style-type: none"> M.L.L. M.B.A. M.I.T. M.C.A. M.L.P. 	2	6 months		Build Bright University
<ul style="list-style-type: none"> • Bachelor of Business Administration • Bachelor of Laws • Bachelor of Arts in English • Bachelor of Arts in Architecture • Bachelor of Tourism • Bachelor of Information Technology • Bachelor of Business Legal Literature • Bachelor of Engineering 	<ul style="list-style-type: none"> B.B.A. B.A. B.A. B.A. B.T. B.S. L.L.B. B.Eng. 	<ul style="list-style-type: none"> 4 4 4 4 4 4 4 5 	6 months		

* Years to complete reflects normal course of study.

The extraordinary variety of degrees and academic awards in Cambodia can be attributed to the various influences in the country in the past 30 years. The French and then the Soviet and Vietnamese influences are clear. Recently, higher education institutions in the region have also lent their influence to the system. Cambodia would like to be at par with international standards and this is an essential effort of the Higher Education Reform.

All students enrolled between 1992 and 1994 studied one year more in “Preparatory class for higher education”. The preparatory class was created in 1992 and abolished in 1995.

5.1 Sequence of study

In general, the study programmes can be divided into two sequences. The first sequence is composed of two or three years providing general education (foundation years or common courses) and the last sequence offers specialization or professional education. Students follow their respective course programmes in the first and second sequence and take examinations during and at the end of each course. They graduate and get their degree when they have successfully passed all examinations. In some institutions like ITC and the Royal University of Agriculture, in addition to examinations, students are required to prepare and present a project in order to get their degree.

5.2 Practical experience

Practical experience or work experience accumulated in private or public enterprises during the period of study is mandatory. The duration for work experience differs among institutions and the relevance of the opportunities for work. For the National Institute of Management, the course programmes end with an assignment in six months, carried out in private or public enterprise in order to write a project report before the final examination. In the University of Health Sciences, practical experience commences in the first semester of the third year on a daily basis. This work experience lasts for three years. Internship is required in the last year of study. For engineering course programmes, one month of work experience is required at the end of Year 1, 2, and 4, and the last semester of Year 5 is devoted to work experience in order to write a project report (Memoir).

5.3 Grading and evaluation

Students have to pass all end-of-semester examinations, and in the last year of study, they have to pass a final examination. The grading system differs from one institution to another. Existing grading systems used by institutions can be summarized as: 10/10, 20/20, 100/100, and so on.

10/10	20/20	100/100		
9-<10	18-<20	90-<100	A	Excellent
8-<9	16-<18	80-<90	B+	Very good
7-<8	14-<16	70-<80	B	Good
6-<7	12-<14	60-<70	C	Average
5-<6	10-<12	50-<60	D	Pass
<5	<10	<50	F	Failure

In some institutions, to obtain a degree, students must have an average of >6/10.

6. ADMISSION REQUIREMENTS

The certificate of upper secondary education is required for all applicants to enter institutions of higher education. From 2002, admission is based on the results of completion of high school. The Ministry of education, Youth and Sports is responsible for organizing the selection committee in each institution. For some fields of studies like foreign languages, the successful candidates in written examinations have to pass oral examinations.

7. DEGREE CONFERRING AGENCIES

In general, degrees are conferred by the individual institution and approved by the Ministry of Education, Youth and Sports. The Royal Kret of Accreditation Committee of Cambodia (ACC) provides a legal mechanism for administering the accreditation of higher education for all HEIs to ensure and promote academic quality for greater effectiveness and quality consistent with international standards.

8. ASSESSMENT OF HIGHER EDUCATION INSTITUTIONS

Following the adoption of Sub-decree No. 01 of 1992, the Ministry of Education, Youth and Sports has an overall responsibility of formulating regulations, rules, policies, etc. for higher education institutions, which involves monitoring and inspecting institutions in order to improving the quality of education. In practice, the ministries concerned play an important role in the assessment of fields of specialization. Internal evaluation is an academic quality assurance process by which each HEI shall regularly review its annual standards to ensure that its teaching-learning objectives as well as other objectives are fulfilled. The ACC will provide instruction regarding this internal process.

External evaluation involves the HEI reporting to the ACC on progress towards meeting the HEI's goals and improving areas identified by the ACC in the accreditation process.

9. DEGREE AND PROFESSIONAL COMPETENCE

Generally, diplomas are conferred on degree holders after a period of practice. Therefore, the degree holders are entitled to professional practice after graduation. For Medicine, Pharmacy and Dentistry, although they have submitted to an internship during the last year of study, degree holders are required to work successfully one more year after graduation before they are entitled to professional practice. This is analogous to a license. There is an effort being made at present to increase the practical aspects of all areas of higher education so that there is a clear relationship between what one studies and how one can contribute to national development.

10. INTERNATIONAL RECOGNITION OF DEGREES

In January 1988, the Cambodian government signed a protocol with the government of the former Soviet Union concerning the recognition and equivalence of degrees, diplomas and certificates granted by institutions of both countries. Similar protocols of recognition and equivalence of degrees, diplomas, and certificates were signed in March 1989 between the government of Cambodia and governments of Laos and Vietnam. The degree received by graduates of the Foreign Language Teacher Training at Royal Phnom Penh University in English and French are recognized by institutions around the world. The Australian and French governments support and monitor these two programmes, as well as provide regular financial support.

Cambodia is a signatory of the UNESCO Regional Convention on the Recognition of Studies, Diplomas and Degrees in Higher Education in Asia and the Pacific which was held in Bangkok, Thailand on December 12-16, 1983. However, the Cambodian government has not yet ratified this agreement.

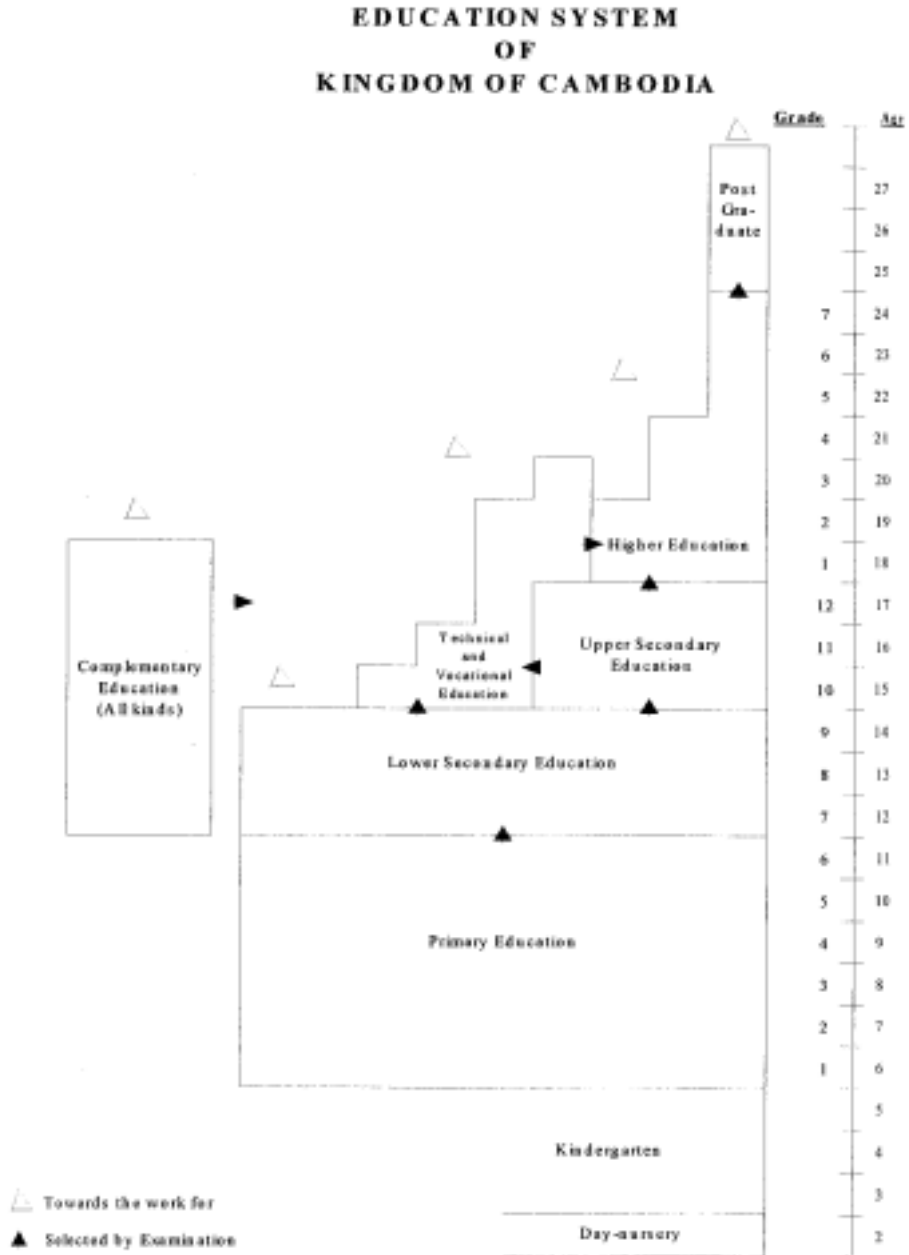

THE PEOPLE'S REPUBLIC OF CHINA

Bie Dunrong Mi Junkui Xu Jianling

1. COUNTRY PROFILE

The People's Republic of China, called China for short, is a country situated in East Asia with a total area of 9,600,000 square kilometres. China is divided into 22 provinces, 5 autonomous regions and 4 municipalities directly under the control of the Central Government. China has re-exercised its sovereign rights over Hong Kong on July 1, 1997 and over Macao on December 31, 1999. China is a country of 56 ethnic groups among which the Han group is the majority. Chinese (commonly spoken) is the official language. The total population is over 1.2 billion. The Chinese civilization is one of the oldest in the world.

Since 1978, the Chinese Government has implemented a policy of reforms and opening-up to the outside world; the social politics has been kept stable; the increase of the national economy has been continually kept at a rapid pace; the life of the people in the city as well as in the countryside has been improved; and a variety of social causes has been completely addressed.

2. NATIONAL EDUCATION SYSTEM

Education in China has an age-old tradition. As a result of textual research, China had developed the embryonic form of schooling system during the West Zhou period (1100 B.C.-771 B.C.), which is over 2000 years ago.

China runs the biggest education system in the world. The current national education system in China includes four levels, namely, pre-school education, primary education, secondary education and higher education.

Pre-school education is mainly undertaken by kindergartens that admit three to six years old children. According to the statistics of 2001, there were 175,836 kindergartens with a total enrollment of 22,441,800 children.

Primary education mainly refers to schooling in full-time primary schools that admit six or seven years old children. The length of schooling in primary schools is five or six years. Primary schools impart all-round development of morality, intelligence and health to all pupils. In 2001, there were 553,622 primary schools with a total enrollment of 130,132,500 pupils and the net enrollment rate of school-aged children reached 99.1 per cent. There were 1,539 schools for special education catering to the needs of the blind, the deaf-mute, and the mentally retarded children, with a total enrollment of 377,600 students. More than half of the school-aged handicapped children have access to education. Besides, there are primary schools for adults, which provide elementary education and literacy classes to workers and peasants who have not finished their primary education.

The structure of secondary education is divided into two tracks, one is general secondary education, the other is vocational and technical secondary education, among which each covers two stages: junior secondary and senior secondary. General secondary education is undertaken by general junior and senior secondary schools, and vocational and technical secondary education is undertaken by specialized secondary schools, skilled workers' schools and vocational schools as well as short period vocational and technical training of various types. The duty of secondary education is to foster qualified newcomers for higher level schools and to train reserved work personnel for the manpower market. In 2001, there were 63,900 junior secondary schools with a total enrollment of 62,562,900 students; 14,600 senior secondary schools with a total enrollment of 12,012,600 students, 1,194 vocational junior secondary schools with a total enrollment of 886,400 students; 7,655 vocational senior secondary schools with a total enrollment of 4,145,600 students; 3,646 specialized secondary schools with 4,895,200 students enrolled; and 3,792 skilled workers' schools with 1,401,000 students enrolled.

Higher education is the highest stage of the national education system providing higher professional education on the basis of secondary education, which is usually divided into three categories, including short-cycle courses or schools, undergraduate courses and postgraduate programmes. There are two kinds of institutions that provide higher education, namely, regular higher education institutions (HEIs) and adult (HEIs).

3. HIGHER EDUCATION SYSTEM

3.1 Higher education institutions

Higher education institutions in China include regular HEIs and adult HEIs. Regular HEIs, which provide full-time programmes for higher education degrees and diplomas, refer to specialized higher learning schools, short-cycle vocational colleges, four-year colleges and universities, etc. Postgraduate schools, formed in four-year colleges, universities and national scientific research institutions with the authorization of the Degree Committee of the State Council, are responsible for management and organization of postgraduate education.

Adult HEIs, attached to the continual education system for adults' higher education in-service, take a variety of types, including radio-TV universities, spare-time universities, workers' universities, farmers' universities, autonomous correspondence colleges, teachers' advancement colleges, colleges for management, etc. There are also correspondence courses, night schools and advanced training programmes for adults attached to regular colleges and universities. Students enrolled in institutions mentioned above are mainly in-service staff with access to part-time, full-time or spare-time courses. Programmes for adults are more flexible in these institutions; diplomas or certificates are issued accordingly on the basis of completion of required courses (or academic credits) and passing the examinations.

In 2000, there were 1,041 regular HEIs, among which 599 colleges and universities offered degree level programmes and 442 institutions offered short-cycle programmes. The total enrollment of regular HEIs was 5,560,900, and there were 772 adult HEIs with a total enrollment of 3,536,400 students. In addition, there were 323 scientific research institutions offering postgraduate programmes for students of master's and doctor's degrees as well.

Besides, private higher education in China has been developed very rapidly. At the end of 2000, there were about 1,282 private colleges and universities, among which 43 of them were qualified and authorized to award diplomas.

China has also developed a self-study examination system of higher education. Citizens can voluntarily apply to take examinations held by the Government on the basis of self-study of higher education courses. Diplomas of higher education are conferred to those who have passed all examinations of the required courses.

3.2 Co-ordination of higher education

Colleges and universities in China are administered through a unified control governance and management at two levels: the Central Government at the upper level and the provincial governments at the lower level. The State Council and the Ministry of Education are responsible for overall policy-making, development planning, reform arrangement and direction of higher education on the nation-wide scale, and co-ordination of relationships among ministries and commissions of the Central Government and the provincial governments on issues of higher education. The Ministry of Education also directly controls 71 regular universities.

Other ministries and commissions of the Central Government directly control 49 regular HEIs, while 896 regular colleges and universities are under the direct control of the provincial governments. The main responsibility of these government authorities is to manage the admission size, assessment of establishing two to three years short-cycle programmes, financing and employment of graduates of colleges and universities (on the basis of governance relationship) in accordance with national policies and the laws of higher education.

3.3 Institutional administration

The internal administration and management of colleges and universities in China is undertaken by a system in which the president takes the responsibility under the leadership of the Communist Party Committee on the institutional base accordingly. CPC keeps a unified leadership through examination and decision-making of institutional development and reform, as well as events of vital importance in the operation of the institution.

The president of a college or university, as the representative of the institution, is the chief executive appointed by the government, whose responsibility mainly includes organizing the operation of teaching, scientific research and social services, fund-raising, co-ordinating and developing external relationships, etc. The presidents of the universities under the governance of the Central Government are appointed by the Central Government, while the president of a provincial HEI is appointed by the provincial government.

The Council of a college or university, headed by the General Secretary of CPC or the president, mainly composed of vice-presidents, vice-general secretaries, deans, heads of departments, faculty representatives and other necessary staff, serves as an organization for examination and decision-making on major issues of institutional operation, etc.

The Academic Council, mainly composed of the president, academic vice-president and faculty representatives, is set to deal with examination and approval of academic strategies and development plan, research projects and postgraduate education programmes, as well as examination and promotion of professorships and associate professorships, etc.

The Conference of Staff Representatives, composed of faculty representatives (60 per cent) and other staff representatives (40 per cent), is held periodically to examine and comment on the

report of the president, and to make suggestions on important issues regarding teaching, research, staff welfare, etc.

The Degree Committee of a college or university with the authorization of the Degree Committee of the State Council, mainly composed of the major academic officials and professor representatives, is set to make policies and regulations concerning graduate education, approves application for bachelor's, master's and doctor's degrees, makes decisions on admission examinations for candidates of master's and doctor's degrees, and manages other issues related to degree conferring.

Departments of various study areas are organized within a college or university, in which the heads take the responsibility of implementing policies and programmes of teaching, research and other academic activities on departmental scale.

4. CHARACTERISTICS OF DEGREES AND DIPLOMAS

4.1 Types of degrees and diplomas

Degrees and diplomas are conferred to graduates respectively at colleges and universities. Degrees are divided into three kinds and levels: bachelor's, master's and doctor's. Graduates from four- or five-year college programmes, master's programmes and doctor's programmes can obtain graduation diplomas respectively; those whose academic performance have reached the requirements of the Degree Regulations of the People's Republic of China can obtain bachelor's, master's or doctor's degrees accordingly.

Besides, there are still some other diplomas and certificates conferred at colleges, such as diplomas conferred by specialized higher-learning schools and short-cycle colleges, certificates for graduates from assistant professor classes at universities, certificates for graduates from postgraduate classes, certificates for post-doctoral research, etc.

The honorary doctor's degree is conferred to some domestic or foreign outstanding scholars or famous social activists by a college or university with the approval of the Degree Committee of the State Council.

4.2 Titles of the degrees and diplomas

Degrees and diplomas are conferred at colleges and universities in accordance with the divisions of relevant branches of learning, which include philosophy, economics, law, pedagogy, arts, history, science, engineering, agriculture, management and medicine. The titles of degrees and diplomas consist of the above branches of learning, e. g. Bachelor of Philosophy, Master of Philosophy and Doctor of Philosophy, Bachelor of Economics, Master of Economics, and Doctor of Economics, etc.

Degrees and diplomas above are general or academic. Currently, colleges and universities are authorized to confer professional or practical degrees, and a number of such kinds of degrees has been conferred to graduates, e.g. Master of Engineering, Doctor of Engineering, Master or Doctor of Clinical Medicine, Master of Education, Master of Business Administration, Master of Public Administration, etc.

4.3 Information contained in the document

After the examination and approval of the Degree Committee of a college or university, certain degrees can be conferred to graduates. The documents of bachelor's degrees are issued by the Ministry of Education of the Central Government, while the documents of master's and doctor's degrees are issued by the Office of the Degree Committee of the State Council.

In the degree document, there is the national emblem of the People's Republic of China printed, with clear handwriting of the specific branch of learning and the title of the degree conferred to indicate the academic level that the degree recipient has reached in the discipline. The document can be valid only when the handwriting in it conforms to the provision of filling in, the metal seal of the college or university is affixed, and the names of the president and the chairperson of the Degree Committee are signed on it

5. STUDY PROGRAMMES

5.1 Number of credits

During the period of over-centralized control, colleges and universities had little autonomy in development of the curriculum and the study programmes. Since the over-centralized control has been gradually reformed and changed, colleges and universities are encouraged to make reforms to the curriculum in accordance with the requirements of the society and the actual conditions of the institution. Thus, the school-year system and the credit system are combined together to foster students' creativity and adaptability.

The duration of study in most colleges and universities of regular courses for bachelor's degrees is 4 years, while that of the medicine and some engineering programmes is 5 years. Students are required to complete all the required courses of total credits within the provision of the duration for graduation. In the credit system reform of many universities, the duration for graduation is much more flexible than before. Students are allowed to choose graduation time, and they can finish required study in 3 to 8 years.

The required credits for graduation among colleges or universities of regular courses are different from each other, since the duration of study, the major fields of study, methods of counting credits and the courses provided among different institutions and programmes are quite different from each other. For example, at Xiamen University, the minimum total credits for graduation of regular 4-year students is 150, and that for graduation of regular 5-year students is 190, while at Zhejiang University, the minimum total credits for graduation of regular 4-year students of engineering is 125-130, and that for graduation of regular 5-year students of engineering is 150-155. In Huazhong University of Science and Technology, the required credits for graduation in the applied physics programme is 174.5, while that for Mathematics and applied Mathematics programme is 166.5.

The study duration for master's degrees is 2-3 years. Since the numbers of required courses for students of master's degrees among colleges or universities do not differ much from each other, the minimum credits for graduation among different institutions is more or less the same. For instance, at Xiamen University, students of master's degrees have to gain 32-34 credits in the course of study for graduation, while at Zhejiang University, students of master's degrees have to take courses of 30-35 credits, and in Huazhong University of Science and Technology, the required credits for master's degrees are 32.

Students of doctor's degrees take research as the major work of study programmes in which a certain number of degree courses that amount to 12-16 credits are included. The duration of a doctor's degree programme is generally 3 years, while that for those in-service is usually about 4-5 years.

5.2 Sequence of the study

Students of colleges and universities in China are admitted and educated on the basis of divisions of specialization. The structure of curriculum and sequence of study provided in the programmes for degrees of different levels are thus accordingly different.

Programmes for bachelor's degrees generally contain common obligatory courses, basic courses, specialized courses or groups of specialized courses, etc. Students have to choose courses to study systematically, as a rule, common obligatory courses and general basic courses are usually in the first half of the study duration, and specialized basic courses are usually in the last half.

Common obligatory courses are generally required for all students of different areas of specialization at a college or university, which mainly consist of courses of political science, ideological education, foreign languages, computer, physical education, etc., to provide general education to students. Current political policies, morality education, productive work, military training, application of computer, Chinese, etc., are offered in the programmes as common obligatory courses in a number of colleges or universities. General education has attracted the attention of many universities in the present reform of higher education. Some universities have implemented experimental programmes in general education, while other universities are carrying out complete credit systems to enhance general education.

Basic courses are proposed to enable students to obtain knowledge of basic concepts of natural and social sciences, to gain preliminary training of basic skills, to enhance students' all-round qualities, and to build up a sound and solid foundation for later specialized learning. The instruction of basic courses does not necessarily emphasize on students' specialization and immediate practice. For instance, the objective of basic technological courses is to enable students to lay a theoretical foundation for learning in specialized fields in science or engineering in their future study, and obtaining further training in basic skills. In some universities, along with the instruction reform of undergraduate education, the basic courses are more or less concentrated to courses of discipline foundation, that is to say, a number of courses is provided in accordance with a specific discipline, which is intended to strengthen the specialized knowledge base of students in a relevant discipline.

Basic courses can be further divided into general basic courses and specialized basic courses. Students of the same specialization or the same branch of learning are usually required to study those courses of the same. For instance, students of engineering are required to study courses, such as higher mathematics, physics, mechanics, cartography, etc., which are regarded as general basic courses, while courses such as mechanical principles, material mechanics, mechanical cartography, etc. are taken as specialized basic courses for students specializing in 'mechanical manufacture'. The study of basic courses is regarded as a transition from general education to specialized education.

Specialized courses enable students to master necessary knowledge and skills in their special fields of learning, and to keep up with the latest achievements and trends of changes in their

major fields. These courses usually emphasize instruction of specialized theories and principles, as well as training of skills in lab work and other experiments. Therefore, students from a certain specialization are required to study specialized courses provided for that specialization. For instance, students majoring in mechanical manufacture are required to choose courses such as mechanical manufacturing technology, metal cutting and knife instrument, precise processing technology, machine tool designing, etc. Some colleges or universities offer several groups of more specialized and comprehensive courses in the programmes for students to choose, so that special skills and capacities of students can be developed.

Postgraduate programmes are designed to help postgraduate students to master specialized fundamental theories and systematic professional knowledge and practical skills.

Students of master's degrees are usually required to study courses in the first half of the study duration. A master's degree student can only enter the dissertation preparation stage when he or she has completed all required courses and obtained the required minimum credits. It should not take less than one year for students of master's degrees to prepare for their dissertations. Students enrolled in postgraduate classes of non-degree award are only required to study courses; dissertation preparation is not contained in their study programmes.

Postgraduate courses include obligatory courses and elective courses. Obligatory courses are those of political science, foreign languages and three or four specialized basic theoretical courses and specialized courses, while elective courses are more open and usually include a second foreign language, postgraduate courses of other departments or other major fields of study or related specialized courses for undergraduates. The credits for elective courses should not be less than one-third of the total credits.

Dissertation preparation should be made independently by students of master's degrees under the supervision of advisers. The dissertation must reveal new understanding of the subject, and shows that the writer has developed necessary abilities for conducting scientific research independently in the relevant major field.

Doctoral students usually start to prepare their dissertations after having finished studying required courses. The required courses include political science, foreign languages and two or three specialized foundational theoretical courses and specialized courses. Doctoral student accessed from other major fields or without obtaining master's degrees are required to take some specialized courses in the programmes for master's degrees in addition according to their current major fields, but no credits should be given.

Dissertation preparation of doctoral students should take two thirds of the study duration, and be finished independently under the supervision of advisers. The dissertation has to show that the writer has mastered the fundamental theories and professional knowledge of the major field broadly and systematically, has developed abilities to conduct scientific research independently and effectively, and has achieved new professional results in the relevant major field with theoretical or practical value.

5.3 Practical experience

Practical experience is taken seriously in the programmes of undergraduate education at colleges and universities in China. It is generally required in the programmes and certain credits are given to it in a number of colleges or universities. Practical experience usually takes the form of practice

teaching, probation, productive labor, military training, social investigation and services, scientific research, etc. The allocation of academic hours to these activities in the programmes of regular courses is by and large as follows: 4-8 weeks or so for productive labor and military training, and the time for practice teaching and probation depends on major fields of learning, i.e., 3 weeks for the major fields of science, 10-14 weeks for the major fields of engineering, 20 weeks for the major fields of agriculture, and 6 weeks for practice teaching. Time provided for other activities of practical experience is different among colleges or universities, some of them such as social investigation and services are carried out in the summer or winter vacations. There are also differences among colleges and universities, even among different major fields of study within a university. For instance, at Huazhong University of Science and Technology, the total credits required for major practical training, extra-curricular activities and practice are 37 in the programme of Mathematics and Applied Mathematics, 47 in the programme of Materials Science and Engineering, and 62 in the programme of Industrial Design.

Postgraduates are required to take practice teaching or other practical work such as lab work, work as assistant administrators before graduation, and the academic hours allocated to it is about 4 weeks.

Doctoral students should engage in scientific research and participate in activities organized by relevant teaching units or research units of the department or institute. Those who have not experienced employment before have to participate in activities of social practice, but there is no unified provision among colleges and universities. Students of master's and doctor's degrees are also nominated as part-time assistant professors, assistant researchers or assistant administrators at colleges and universities. These are intended to enrich practical experience of students.

5.4 Grading and evaluation

Students are required to pass an examination or test at the completion of each course. Examinations usually employ forms of written examination, oral examination, formal assignment, or experimental operation, while tests mainly adopt forms of class tests, record of class attendance and performance, exercises, short papers, etc. The obligatory courses generally take an examination, but the elective courses may choose either an examination or a test as the requirement of a specific programme.

Both the examination and the test should be graded. The results of examinations are assessed by either a hundred-mark system or a 5-grade system (excellent, good, fair, pass and fail). The conversion principle between two systems is as follows: 90 and above equals excellent, 80-89 equals good, 70-79 equals fair, 60-69 equals pass and 59 and below means fail. The results of tests are generally assessed by two grades, qualified or unqualified. Certain credits are granted for each course upon passing the examination or test at colleges or universities where the credit system is practised. The final examinations and tests at the end of a term or a school year are usually organized upon a unified agreement by the institutional authority.

As for students of master's degrees, the 'pass' requirement of an examination for an obligatory course is 70 marks, while a qualifying grade for the test of an elective course for 'pass' is set, and credits are granted upon passing an examination or a test.

As for doctoral students, examinations of obligatory courses are more flexible, however, it is required to keep the records of examinations and answers in written examinations, records or tape recording in oral examinations, and manuscripts or written materials in academic reports.

For graduation in colleges or universities, students are required to obtain all-round development in three perspectives: morality, intelligence and health. Each student is given a comprehensive evaluation before graduation and only those who can pass the evaluation will be granted graduation.

6. ADMISSION REQUIREMENTS

An annual, unified College Entrance Examination (CEE) is held by the Ministry of Education for the enrollment of all colleges and universities in China. Requirements for applicants to access colleges or universities are as follows: loving the motherland, high morality, abiding by the laws and regulations, graduation from upper secondary schools or possessing equivalent intelligence for studies, and healthy. Young people manifesting excellence with rich practical experience may access colleges and universities without taking the college entrance examination upon the approval of the government authority.

The admission to colleges and universities is under the leadership of the Ministry of Education, whose responsibility covers decision-making of the policies, standards, subjects, dates of the examination, etc. The college admission offices of local governments are in charge of organization and management of application, examination and recruitment. Colleges and universities recruit students selectively upon comprehensive examination of the applicants from three perspectives: morality, intelligence and health in accordance with the authorized admission programme.

Traditionally, there are two group examinations of subjects provided for the applicants to choose in CEE. One group is political science, Chinese, mathematics, history, geography and foreign languages for applicants of humanities and social sciences; the other is political science, Chinese, mathematics, physics, chemistry, foreign languages and biology for applicants of science, engineering, agriculture, medicine, etc. At present, some changes have been made to the courses of the two group examinations: applicants of both groups have to take examinations of three common courses, including Chinese, mathematics and foreign languages, while an elective comprehensive examination is provided to each group. Applicants can choose the comprehensive examination either for humanities and arts, social sciences or for mathematics, natural sciences and engineering.

There are options of six foreign languages in CEE for applicants to choose from, which include English, Russian, Japanese, French, German and Spanish.

Since 1993, reforms have been carried out in the CEE in Beijing City and some other provinces with the approval of the Ministry of Education, in which subjects taken in the examination have been changed into: Chinese, mathematics, foreign languages, political science and history for examinees of humanities and social sciences; and Chinese, mathematics, foreign languages, physics and chemistry for examinees of science, engineering, agriculture, medicine, etc. After 1999, new reforms have been tried out again, in which courses of the examination have been changed into: 3 plus X where '3' means courses of Chinese, mathematics and a foreign language that are obligatory courses for all applicants. 'X' means that there is an examination of some courses provided, such as physics, chemistry, biology, political science, history and geography and applicants can choose some courses, in accordance with their advantage and the offerings of specific colleges or universities.

Overseas Chinese and applicants from Hong Kong, Macao and Taiwan are admitted to Jinan University in Guangdong Province, Overseas Chinese University and Xiamen University in Fujian Province, Beijing University in Beijing City, and more than 60 other colleges and universities with the approval of the Ministry of Education. The requirements for these applicants are as follows: graduation from upper secondary school (equal to the sixth grade in secondary schools), good manners and right conduct, free from mental and infectious diseases, and generally healthy. Courses taken in the admission examination are as follows: Chinese, mathematics, history, geography and English for applicants of humanities, arts and social sciences; Chinese, mathematics, physics, chemistry and English for applicants of science, engineering and agriculture; Chinese, mathematics, physics, chemistry, biology and English for applicants of medicine. In 2002, the mainland colleges and universities enrolled 766 applicants from Hong Kong, 1,131 from Macao, 816 from Taiwan, enrollment at Jinan University and Overseas Chinese University not included.

Examination rooms are set up in Guangzhou City, Xiamen City, Hong Kong, and Macao for the convenience of the applicants. Traditionally, the examination date is fixed in the second weekend to the next Monday in June each year. The cut-off score for recruitment is decided by the Ministry of Education; colleges and universities recruit applicants selectively according to the grades and other relevant information provided by the applicants.

There are three ways for postgraduate admission in China that include national standard examination, recommendation without specialized course examination and examination held by individual colleges or universities authorized by the office of the Degree Committee of the State Council, among which the first way is the major. The requirement for applicants mainly covers: loving the motherland, good morality, abiding by the laws and regulations, graduation from college or university of regular courses or possessing equivalent academic intelligence, healthy, and below 40 years old. Applicants for postgraduate education in service can exceed 40 years old.

The postgraduate admission examination is divided into two parts including preliminary examination and re-examination. Before 2002, courses taken in the national standard preliminary examination are as follows: political science, foreign languages and three specialized ones, but the courses for specialized examination have been changed into two since 2002. The examination papers for political science, foreign languages and some other common courses are prepared by the Ministry of Education, while the examination papers for specialized courses are generally prepared by individual colleges or universities. The re-examination is a kind of face-to-face test held for applicants who have passed the preliminary examination. The dates and methods for re-examination are basically decided by individual colleges or universities. The contents of re-examination now include a specialized face-to-face test, an oral test of foreign languages, and a test of a specialized basic course. The re-examination usually employs modes of oral examination, written examination, experiment operation, skills test, etc. Marks or comments should be given to the results of the re-examination. Colleges or universities selectively recruit those who have passed the re-examination and conformed to other requirements for admission in accordance with the admission plan issued by the Ministry of Education.

Admission of doctoral students is operated separately by individual colleges or universities under the direction of the Degree Committee of the State Council. The requirements for applicants are as follows: loving the motherland, high morality, abiding by the laws and regulations,

master's degree awarded or possessing equivalent academic intelligence, healthy, usually not exceeding 45 years old, and recommendations of two professors or associate professors in the relevant major field.

The examination for doctoral students' admission is also divided into preliminary examination and re-examination. The subjects, date and question items in the examination are decided by individual colleges or universities. The preliminary examination usually includes one foreign language and two or three specialized subjects. Applicants with equivalent academic intelligence should take an additional examination that contains two or more specialized subjects. The re-examination is held by a group of faculty members composed of advisory professors and some other relevant professors, and systems of oral examination, written examination or experiment operation are usually adopted. A grade is given by the group to the re-examination result either excellent, good, pass or fail. Only those who have passed the preliminary examination and re-examination with better achievement be recruited by the institution authorized by the Degree Committee of the State Council considering provisions for qualifying characteristics in morality, health and other conditions.

7. DEGREE CONFERRING AGENCIES

In China, bachelor's degrees are conferred by colleges or universities authorized by the Ministry of Education, while master's and doctor's degrees are awarded by colleges, universities or national scientific research institutions authorized by the Degree Committee of the State Council.

A college or university that is qualified to confer bachelor's degrees should:

- be able to provide basic courses of the major fields mostly taught by qualified faculty with titles above lecturer;
- be able to provide supervision in required laboratory work at a fairly high level;
- have a certain number of teachers with titles above lecturer to supervise graduates to complete their theses or graduate projects; and
- have established a sound examination and assessment system for grading results of instruction and learning.

An institution that is qualified to award master's degrees has to reach the following requirements in the corresponding fields of learning:

- having developed its faculty with a fairly high academic level in teaching and research;
- the advisers of postgraduates are generally required to be professors and associate professors;
- able to provide all obligatory courses and selective courses on basic theories, specialized theories and laboratory operation;
- able to provide necessary equipment for experiments and research, and reference materials for completing dissertations; and

- having established a sound examination and assessment system for postgraduate education.

The accreditation of awarding doctor's degrees is mainly limited to those key colleges, universities and national scientific research institutes. Some major fields in other universities with the following conditions can also be qualified to award doctor's degrees:

- having adviser professors with fairly high academic attainments and outstanding achievements in teaching and research;
- able to provide favorable conditions of learning and research for doctoral students to the fullest extent of need to complete required studies; and
- having established a sound examination and assessment system for programmes of doctoral students.

By 2002, there were 599 colleges and universities authorized to confer bachelor's degrees, 457 colleges and universities authorized to confer master's degrees, and 245 colleges and universities authorized to award doctor's degrees.

The system of accreditation and assessment of HEIs in China has been newly set up since 1980s, and is still not completed. The accreditation and assessment of colleges or universities are under the leadership of the Ministry of Education of the State Council and the provincial governments, and implemented by the leading groups and expert committees founded in the ministries and commissions of the Central Government and the provincial governments.

8. ASSESSMENT OF HIGHER EDUCATION INSTITUTIONS

The National Accreditation Council of Higher Education Institution (NACHEI) was established by the Ministry of Education with the responsibility of accreditation of all colleges and universities in the country. The accreditation process for regular HEIs is as follows :

- (a) The Ministry of the central government or provincial government that plans to establish a regular college or university applies to the Ministry of Education for accreditation. The application is divided into preparation application and admission application.
- (b) The application authority prepares a demonstration report on the basis of foundation demonstration. The report has to cover the following aspects: the name of the college or university proposed, site of the institution, major fields of learning and areas of specialization to provide, education objectives, size of student intake, leadership systems, regions of admission and employment of graduates, forecast of the requirement of manpower and efficiency of education, sources for faculty recruitment and fund-raising, capital build-up programme, etc.
- (c) ACHEI examines the application and documented report with the entrustment of the Ministry of Education, and recommends approval of the Ministry of Education.
- (d) NACHEI examines the first graduates of the newly built college or university according to the standard provision, in order to ensure the quality of the programme of study.

The college or university, establishment approved by the Ministry of Education, has to satisfy the indicators monitored as to size, faculty development and other education conditions in 10 years from the date of approval. The Ministry of Education or an organization entrusted by the Ministry of Education is responsible for this evaluation.

The evaluation of study programmes of colleges or universities is implemented by evaluation committees set up by relevant government authorities. The process of study programme evaluation generally includes the following steps:

- (a) Individual college or university applies for evaluation of the leading group of the evaluation committee for respective programme or relevant government authority.
- (b) The college or university plans and carries out self-evaluation in accordance with the standard evaluation indicators, and submits a self-evaluation report to the leading group or the evaluation committee entrusted.
- (c) Field investigation is done by an expert group entrusted by the evaluation committee, and an evaluation report with conclusions or suggestions is prepared and submitted to the evaluation committee by the expert group on the basis of examination of the self-evaluation report and field investigation.
- (d) The evaluation committee poses a formal evaluation conclusion on the basis of the expert's report.
- (e) The leading group approves the report after examining all evaluation documents, and reports the conclusions to the Ministry of Education as needed.
- (f) If the college or university disagrees with the report, it can appeal to the Ministry of Education within a month after the evaluation conclusion report has been submitted.
- (g) The leading group of study programmes evaluators of the Ministry of Education will organize a new group of experts to re-examine the study programmes and the evaluation report made by the former leading group, and makes an arbitration which is the final report on the evaluation.

The accreditation of private HEIs is different from the public ones. The preparation application of a private college or university should be submitted to the education authority of the provincial government. A group of experts formed by the authority is responsible for examining the preparation application and completing an examination report with conclusions. The report is submitted to the provincial government for approval. If the application is approved, a copy of the approval should be sent to the Ministry of Education to be documented.

The accreditation process of the admission application of a private college or university is somewhat more complicated, as it is done in the following process:

- (a) The founder applies for admission accreditation to the corresponding provincial education authority.
- (b) The application is passed on to the Ministry of Education on the basis of the examination and approval of the provincial government.

- (c) NACHEI, entrusted by the Ministry of Education evaluates the application and prepares an accreditation report with subsequent recommendations.
- (d) The Ministry of Education makes the decision to approve or disapprove based on the examination of the application, accreditation report and notices of the provincial government.

9. DEGREE AND PROFESSIONAL COMPETENCE

The holders of degrees and diplomas of higher education have been regarded as cadres of the country with vocations or jobs provided or allocated by the government for tens of years. Since the middle of 1980s, the system of professional qualification and license has been put into practice. Entrance regulation is applied to a number of professions, such as lawyers, teachers, registered accountants, etc.

Degrees and diplomas of higher education are a major requirements for achieving professional qualifications and licenses. For instance, different diplomas and degrees are required for teacher qualifications at different school levels, e.g. teachers of lower secondary schools are required to have diplomas of colleges or universities of short-cycle courses; teachers of upper secondary schools are required to obtain diplomas of colleges or universities of normal courses; teachers of college or universities are required to gain master's or doctor's degrees and diplomas.

10. INTERNATIONAL RECOGNITION OF DEGREES

There has been a gradual expansion of international co-operation and exchange in higher education with the implementation of the policy of opening-up to the outside world. China is one of the signatories of the UNESCO Regional Convention on the Recognition of Studies, Diplomas and Degrees in Higher Education in Asia and the Pacific, which was formally approved by the National People's Congress in 1984.

China has reached a number of bilateral and multilateral agreements regarding recognition of degrees and diplomas of higher education with many countries. By February 2003, China has reached bilateral agreements regarding recognition of degrees, diplomas and certificates of higher education with 16 countries.

China has made great progress in international exchange and co-operation in higher education. The exchange of higher learning students between China and other countries has developed very rapidly in recent years. More than 40,000 Chinese students went to take higher education in foreign countries in 2000, and the amount increased to 84,000 in 2001, and 125,000 in 2002. Among the overseas Chinese students, over 90 per cent paid tuition fees by themselves. Meanwhile, foreign students recruited by Chinese colleges and universities have increased swiftly, too. There were over 14,000 foreign students in Chinese colleges and universities in 1992, but the amount increased to 44,711 in 1999, and more than 90 per cent paid tuition fees by themselves. The co-operation between sino-foreign institutions of higher education has become a new major method in the international education exchange and co-operation in China. By the end of 2002, the institutions or projects of sino-foreign cooperation in higher education were 712, which is nine times the number in 1995. In facing the new situation of international exchange and co-operation in higher education, the State Council enacted Regulations on Sino-foreign

Co-operation in Education in the People's Republic of China, which provides new guidance for international exchange and co-operation in higher education.

11. THE PRESENT REFORM

Since the 1990s, the Chinese government has quickened the step of higher education reforms and made an over-all reform in the aspect of macro-management. The contents of the reform mainly include: preliminarily establishing a new system of higher education management which contains a structure of the two-level management including the central and the provincial authorities with a focus on decentralization of management power as a whole, promoting mass merger of universities and colleges, carrying out the construction of the 211 projects, the world's first-class universities in China, setting up hundreds of vocational and technical colleges, etc. The colleges and universities have largely increased their enrollment since 1999. The gross enrollment rate of higher learning among the adult population has reached 15 per cent in 2002.

1. COUNTRY PROFILE

India is one of the most ancient civilisations in the world with a rich cultural heritage. In the modern period, after long periods of invasions by a series of foreign rulers and British colonial rule for more than two centuries, India attained independence in 1947, and became a republic in 1950. Ever since, the country has made rapid progress in terms of social, economic and cultural development. Five-year plans have been adopted as an important strategy of development in independent India.

India has a federal system of government with two-layer administration: the union government at the centre and state governments at state (or provincial) level. In addition, there are local levels at district and village levels with elected bodies form the third layer of administration. Presently, there are 29 states governed by elected legislatures and six union territories administered by the union government. States are further divided into districts and there are currently 593 districts in all.

The country, geographically spread over 3,287 thousand square kilometres, has an estimated population of 1,037 million in 2002, living in more than half a million villages. Accounting for about 18 per cent of the world's population, India is second only to China in the world. With respect to the size of the total gross national product, India ranks fairly high even among the developed countries, particularly after adjustment for purchasing power parity; but the national income per capita is comparatively very low, (US\$450) in 2000. According to various available estimates, about one-fifth to one-fourth of the population live below the poverty line.

There are 16 prominent Indian languages officially recognised, and numerous dialects. Hindi and/or English are recognised as official languages throughout the country. According to the 2001 census, the effective literacy rate of the age-group 7+ was 65.4 per cent.

There are significant differences in the case of social, cultural and economic dimensions between different states and groups of population. While Hindus constitute the religious majority, other prominent religious groups include Muslims, Christians, Sikhs, Buddhists, and Jains. Differences between religious and caste groups are marked. Generally, public policy provides protection against discrimination to social (identified by religion, caste and gender) and economic weaker sections of the population in education, employment and other social and economic services. Protection against discrimination policies are also in practice in favour of women.

2. EDUCATION SYSTEM

The education edifice in India is one of the largest ones in the world, with a network of 981 thousand institutions with 194 million students enrolled at various levels in 2000-01. Higher

education system alone accounts for more than 8.5 million students (2001-02), though this forms only about six per cent of the relevant age group population. The number of students in all education institutions India outnumbers the total population of Germany, England and Canada taken together. Every sixth student in the world enrolled at primary level, every seventh in the secondary level and every eighth in the tertiary level is an Indian. During the post-independence period, the education system grew rapidly and extensively - 95 per cent of the population are served by a primary school either within their own habitation of residence or within a walking distance of one kilometre. Other levels of educational institutions are also fairly accessible to a large proportion of the population of the country. To note briefly, there are 639,000 primary schools, 206,000 upper primary schools, and 126,000 secondary schools. At higher level of education there are 272 universities and more than 13,000 colleges (2002-03).

In the federal framework, as per the Constitution, education was a 'state' responsibility until 1976, when it was brought into a 'concurrent' list of the Constitution that gave more powers and responsibilities to the union government. But even until 1976, the union government was responsible for the maintenance and improvement of quality in higher education, and a few other areas of school education. In general, though education is a concurrent subject, state governments enjoy a considerable degree of autonomy in designing courses, curriculum, planning and general management of the system. At the higher education level, however, the University Grants Commission (UGC) plays a significant role. Given the changing role of the UGC, there is a move to rename the UGC as Higher Education Development Council.

Both central and state governments have responsibility for providing education. Both together invest about 4.1 per cent of national income on education in 2000-01, as per the latest available statistics. This amounts to about 14 per cent of all government revenue expenditure. The government has resolved to raise the proportion of national income to be invested in education to at least 6 per cent as early as possible.

2.1 Structure of the education system

Like most modern education systems in the world, the education system in India comprises mainly of three levels: primary, secondary and higher. In all, they can be listed in detail as follows:

School Level:

Pre-Primary

Primary

Upper Primary (or middle)

Secondary (or high)

Senior (or Higher) Secondary (or junior/intermediate college)

Post Secondary:

Technical

Higher Level:

Undergraduate Level

Postgraduate (Master's level)

Research (Pre-Doctoral, Doctoral and post-Doctoral) levels

Diploma/Certificate courses

Primary and upper primary level together, known as elementary education has to be provided free to all, as per the Constitution of India. At senior secondary level, there are two separate streams: general (or academic) and vocational. The vocational education stream is not linked to formal higher education, in the sense that students coming out of the vocational stream cannot normally join colleges/universities for undergraduate courses. (Recently, vocational courses are being introduced at college level also.) Further, it has to be noted that an upper primary school is a school offering education from Grade I to Grade VIII (Grade VII in some states). But a secondary school can have Grades I to X or Grades VI to X. So does a higher secondary school - it can have grades I to XII or VI to XII. In some states, the senior secondary level education is provided either exclusively in junior/intermediate/pre-degree colleges of which there are about 4,600 in the country, or in the undergraduate colleges that provide bachelor's degree courses as well. In all school education, including intermediate/junior college level, is of 12 years duration: 10 years (up to secondary) and 2 years of senior secondary level. At the school level, in addition, non-formal education for children of the age-group 9-14 and adult education for the 15+ age group population is provided outside the formal system.

Post-secondary, but not necessarily called higher education, also includes education and training in polytechnic institutions, industrial training institutes and other training institutions that offer post-secondary (matriculate) but below degree level diploma and certificate courses.

Both at undergraduate and postgraduate levels, education leading to not only degrees but also diplomas and certificate courses are offered.

Figure 1 shows the educational structure in general and Figure 2 specifically of higher education in India.

3. HIGHER EDUCATION

Higher education in India includes education imparted after senior secondary level of education (12 years of schooling) and consists of bachelor's and master's degree level studies and doctoral and pre-doctoral level research.

3.1 Types of higher education

Higher education is essentially of two types: general education and professional education. While many normal universities in India provide both types of education, there are some universities, which exclusively provide professional education only, and some are exclusively general. Among the professional universities there are about 40 agricultural universities, about 30 engineering and technological universities, 20 medical universities/institutions, a few management institutions, law universities/institutions, etc. Among the few universities that are devoted exclusively to general education, mention may be made of language universities, institutions of oriental learning, and other such universities. Besides the universities and other institutions, arts, science and commerce colleges and professional (engineering, medicine, agriculture, teacher education, etc.) colleges provide these two types of education, respectively.

3.2 Types of higher education institutions

Higher education is offered in India in a variety of institutions and in a variety of ways as well. The several institutions can be listed as follows:

- Universities:
 - Central Universities,
 - Institutions deemed to be universities,
 - State Universities,
- Institutions of national importance,
- Research institutions, and
- Colleges

Central universities are established by the union government and are funded by the UGC to a great extent, while state universities are established by state governments and are funded by UGC and state governments. There are currently 18 central universities and 178 state universities in the country.

The central/state universities can also be classified into two types: affiliating and teaching, and unitary. Teaching in affiliating universities takes place in colleges (generally undergraduate courses and in a few colleges, postgraduate courses) and in university departments (generally postgraduate courses). The largest number of universities in India belongs to this type, viz., affiliating and teaching. In the case of unitary universities, all teaching, largely confined to postgraduate level, takes place in one campus. There is also a mixed type of university where teaching takes place in constituent colleges and in the university departments. Some special institutions of higher learning, generally specialised in a major area of study, are accorded the status of universities and they are called institutions deemed to be universities, e.g., Indian Agricultural Research Institute, Indian Institute of Science, Birla Institute of Technology and Science, etc. They are not generally multi-faculty institutions. These are also created by and/or with the approval of the central government. Very recently, an increasing number of institutions are being accorded the status of deemed universities. For example, many regional engineering colleges are converted into National Institutes of Technology and are given the status of deemed universities.

In addition, there are 12 institutions of national importance created by the central government, including six Indian Institutes of Technology, the Indian Statistical Institute, the All-India Institute of Medical Sciences, etc. All these institutions and universities, including deemed universities award degrees on their own.

Apart from degree-awarding university-level institutions described above, there are 13,150 colleges that provide mostly bachelor's and sometimes master's level education. A majority of the colleges are arts, science and commerce colleges offering education in humanities, natural sciences and arts. There are 1,195 engineering and technical colleges, more than 700 medical colleges and nearly 800 teacher education/training colleges.

Some of these quantitative details are given in Annex 1. Annex 2 gives a somewhat exhaustive list of the universities and other institutions in the country.

The universities are classified into several, but not necessarily mutually exclusive categories in the Annex. For instance, open universities are listed separately; but the list includes a central open university listed in the list of central universities as well. Most universities listed under state universities are general universities. Exclusive professional universities like agricultural universities, technological universities, medical universities are listed separately. But a majority of them are also state universities. The list is meant to give a flavour of the variety of types of universities and other institutions that India has.

There is yet another type of university level institution, known as research institutions (e.g., Indian Institutes of Management, 40 research laboratories of the Council of Scientific and Industrial Research (CSIR), and institutions that come under the scheme of the Indian Council of Social Science Research (ICSSR) and other institutions. These institutions are not oriented towards awarding degrees, but degrees are awarded through universities with which they are affiliated. Most of these institutions are recognised as centres of doctoral, pre-doctoral and post-doctoral research work. So they do not normally award bachelor's or master's degrees. Some of them offer diploma or certificate courses. The primary function of many of these institutions is non-degree related research, and training in some cases.

Public and private institutions

The higher education institutions in India can be further classified, by management, into two categories, viz., public and private. The public institutions are run by the government - central or state, while private institutions are managed by private bodies. Private institutions again include totally private (or familiarly known as self-financed) institutions with no state assistance, and partially private (state-assisted) institutions. The last category of institutions are generally known as private-aided institutions.

A bill providing for the opening of private universities has been under consideration of the national Parliament. But a few states have passed their own legislations, and private universities began to spring up in those states, rather rapidly. Manipal Academy of Higher Education was the first private higher education institution (with no state assistance), that was accorded the status of a deemed university. There are a few private institutions that are recognised as institutions deemed to be universities, but they receive substantial state support. In other categories, viz., research institutions and colleges, there are public and private (with or without state support) institutions. Given the quantum of state assistance, which often amounts to 95 per cent of the total recurring expenditure of the respective institution, many private-aided institutions, though are run by private bodies, have to follow almost all government rules and regulations, and as a result, they become almost identical to public institutions.

Open learning/distance education

Besides, presently there are ten open universities in the country, including one central university, run by the government. They offer a wide variety of courses leading to diplomas and degrees, many of which are identical to those awarded by formal universities. Many conventional universities also offer correspondence courses through the postal system and they are occasionally supplemented by contact classes. The courses offered and the degrees awarded are generally identical to those of the formal university system. Open universities/distance education systems offer a few additional diplomas and degrees as well. Non-credit courses are also offered by some of these institutions. Most open learning/distance education institutions also begin to use modern technology including audio, video, CD-ROM, and web/internet.

Women's universities

There are also five universities exclusively meant for women, while all other institutions are open to both males and females. There are no universities exclusively for males. Similarly, there are nearly 1,600 colleges in the country in 2000-01, which give admission exclusively to women students. In addition to providing most of the courses available in other institutions, these colleges and universities provide a few additional courses, which are of special interest to women.

3.3 Co-ordination

There are several co-ordinating agencies in higher education in India. While most of the general higher education falls within the jurisdiction of the UGC, professional institutions are co-ordinated by different bodies. The All-India Council for Technical Education (AICTE), established in 1987, is responsible for co-ordination of technical and management education institutions. The other statutory bodies are Medical Council of India (MCI), Central Council of Indian Medicine, the Homeopathy Central Council, the Indian Council of Medical Research (ICMR), Indian Nursing Council, the Dental Council, the Pharmacy Council, the Bar Council of India, the Indian Council of Agricultural Research (ICAR), etc. There are also a few such bodies at state level, such as State Councils of Higher Education which were established recently. There are three other bodies that function somewhat differently, viz., Institute of Chartered Accountants, the Institute of Costs and Work Accountants, and the Institute of Company Secretaries. All the above ones are statutory bodies and each deals with a professional field, dealing with education, training and/or practice. The UGC, AICTE, MCI, and ICAR are some of the prominent ones and others are less popular and less effective. The less popular ones take more interest in the case of practice and training, rather than in formal higher education. There is yet another type of a co-ordinating agency, called Association of Indian Universities (AIU), which was earlier known as the Inter-University Board of India. All the universities and other university-equivalent institutions are members of the AIU. The AIU has no executive powers, but plays an important role as an agency of dissemination of information and as an adviser both to the government and/or UGC and universities.

3.4 Institutional governance

The university governance consists of Visitor (generally in the case of central universities only), Chancellor, Pro-Chancellor, Vice-Chancellor, Pro-Vice-Chancellor, Senate or a Court, Syndicate or Executive Council, the Academic Council and other bodies. All universities do not necessarily have pro-chancellor and pro-vice-chancellor. The visitor (chancellor in the case of state universities) is the formal head of the university. He/She approves all statutes and ordinances made by the Executive Council and he has appellate powers and can request an inspection and inquiry into the functioning of the university. He/She appoints the vice-chancellor. Generally, he/she exercises all these powers through the Ministry/Department of Education of the government (at the centre or state). The Senate or the Court is the supreme body of the university and it has the powers to approve (or repeal) ordinances made by the Executive Council, before they are sent to the Visitor/Chancellor for approval. The Vice-Chancellor is the most important functionary in the university and is responsible for the administration of the university as a whole. He is the principal executive and academic head of the university. He/She is the ex-officio chairman of the Executive Council, the Academic Council and the Finance committee. The Executive Council is the chief governing body of the university and exercises its authority on all matters over administration, governance and financing of the university. It is, however, dependent upon the advice of the Academic Council and other bodies. The Academic Council is a large body exercising powers on all academic matters including new academic programmes, curriculum and degree/diploma programmes, which are to be later approved by the Executive Council before they are sent to the UGC for approval.

At the college level, while the principal is the head of the institution, they are governed by the government, the UGC and the university. While the role of the university in the affairs of the colleges is confined to academic matters, such as curriculum, syllabi and examinations, the role

of the government and UGC extends to planning, administration and financing issues. Colleges have little freedom to design and offer new courses, or to have their own syllabi. The syllabi, courses, etc., have to be approved by the university and the UGC. Mostly, the colleges offer only those courses that are recognised and approved by the university. The courses developed by special colleges like the 'autonomous colleges,' which now number 131 in all belonging to 29 universities in eight states in 2001, established after the National Policy on Education 1986 was formulated, also need to be approved by the university before they are introduced. The main difference between autonomous colleges and others in academic affairs is that while normal colleges adopt the courses developed by the universities, autonomous colleges can develop and propose new courses to the university for approval. Autonomous colleges enjoy academic freedom specially in designing their curriculum, evolving new methods of teaching, research and learning, framing own rules for admission, prescribing own courses of study and conducting of examinations.

4. TYPES AND CHARACTERISTICS OF DEGREES AND DIPLOMAS

Almost all degrees of the universities in India can be classified into three levels: Bachelor's, Master's and Doctoral. Doctoral degrees include pre-doctoral (M.Phil., and Pre-Ph.D.) research degrees. Other levels that include certificate and diploma courses are relatively few. Though most of them are postgraduate diplomas, there are very few undergraduate diploma courses offered by the universities in India. Thus, all courses can be divided into the following:

Certificate and Diploma courses

Bachelor's Degree Courses

Master's Degree courses

Pre-Doctoral Degree Courses

Doctoral Degrees

Annex 3 gives a list of degrees and diplomas awarded by the Indian universities and other institutions of higher education, arranged under various major areas of study.

5. STUDY PROGRAMMES

Undergraduate courses normally are of three years (four or five years in the case of professional courses), and Master's level courses are of two years duration (sometimes three years in the case of sciences and professional courses). Universities have a very varied pattern regarding pre-doctoral and doctoral courses. Pre-doctoral courses leading to M.Phil. (or Pre-Ph.D.) degrees are generally of 1-2 years (or 3-4 semesters) and doctoral studies take 2-5 years in many universities.

The sequence of course programmes is generally structured, i.e., introductory units are followed by fundamental units, which are followed by advanced units. To take advanced units, quite often the successful completion of introductory or fundamental units is a pre-requisite. Within each unit, practical work precedes the theoretical part. The syllabi, several units (papers) and their sequence are to be approved by the university's Academic Council, and later by the UGC or another appropriate body.

A number of diploma and certificate courses of varying duration (less than one year to three years) are offered by universities in India. They also cover a wide range of areas.

Some universities have adopted the semester system at master's and pre-doctoral levels but a majority of the universities and colleges do not follow a semester system.

Generally, the general and professional streams are mutually exclusive, in the sense that one who has taken courses in arts and sciences at the bachelor's level cannot join a professional course at the master's level, while the other way is generally admissible, i.e., those who have studied professional courses at bachelor's level can gain admission to general courses. This kind of streamlining takes place at the senior secondary level itself. In Grade XI in the school, a student has to choose arts, science, commerce courses or professional courses. In the case of professional courses, further streamlining is also made between medical and engineering courses. Those who have studied arts, science or commerce courses at senior secondary level are not eligible for admission into professional courses.

Generally, there is no requirement for any practical experience to obtain a degree in general education. In professional education, such as medicine, however, practical experience in the form of internship is necessary. The curriculum of most technical and professional higher education includes some practical training either in the workshop or in the actual field. The National Cadet Corps (NCC) used to be compulsory for every male student in higher education institutions, but it is no longer compulsory.

Examinations

Examinations are conducted by the universities. Very few universities or institutions have an internal assessment system. The majority of them have only public examination systems and one has to obtain 35-40 per cent of the marks in each paper to pass the course. Many universities allow students to retake examinations to improve their grades/marks. Whatever may be the method of evaluation, the performance of a student is evaluated in every individual course. Based upon the percentage of marks obtained, students are awarded classes/divisions: first class, second class and pass. Some universities award grades such as: A plus, A, A minus, B plus, B, B minus, etc.

The document finally awarded after successful completion of studies mentions the name of the student, the name of the degree, the field of study, the title of examination, year, the name of the university/institution that confers the degree, etc. Most often in the case of bachelor's and master's degree (but rarely in the case of M.Phil. degree) courses, overall grades/divisions are also mentioned in the document. In addition, a grade sheet or a marks sheet is given to every student, including those who fail in the examination, listing the marks/grades obtained in each course. At Doctoral level, dissertations are evaluated at least by three examiners in most cases, including necessarily an external examiner from a foreign university. Successful performance in a *viva-voce* examination is also usually required for the completion of the Doctoral studies.

6. ADMISSION REQUIREMENTS

Admission requirements are varied but the minimum eligibility conditions for entrance into institutions of higher education are somewhat common. Students seeking admission into undergraduate courses (bachelor's degree level education) should have completed normally 12 years of schooling and passed the senior secondary level examination conducted by either national

or state boards. They should be at least 17 years old. There are relaxations in these requirements in the case of distance education or open university programmes that allow much more flexibility. Every institution of higher education can set its own conditions above this minimum eligibility condition, say in terms of per centage of marks secured in the board examination. The majority of the programmes specify additional special requirements. Entrance to most professional courses is controlled by entrance examination conducted by each institution or by a group of institutions in the country or in a state. In a select few areas, the entrance examination is followed by interviews and/or group discussions. Entrance examinations are also held by some universities and institutions for admission to master's level courses and pre- and doctoral studies in general education.

Admission requirements in most degree/diploma courses do not include any practical training or on the job experience. But nowadays for admission in certain advanced courses, some sort of practical experience is being insisted upon. For instance, for degree and diploma courses in business management in some universities (e.g. Indira Gandhi National Open University) some amount of supervisory, managerial or professional experience is an essential qualification. However, such a requirement regarding practical experience is waived in the case of students with higher levels of qualifications (higher degrees).

In consonance with the protection against discrimination policies of the government, most institutions offer relaxed requirements in eligibility conditions to the recognized disadvantaged sections of society, in terms of percentage of marks secured in the qualifying board examination. A proportion of student places in higher education is also reserved for disadvantaged groups, including women.

7. DEGREE CONFERRING AGENCIES

Only universities, institutions deemed to be universities, and other institutions, but not colleges can confer degrees and diplomas. These institutions are authorised to do so when the course programmes have been approved by the concerned bodies like the UGC and AICTE. Since all colleges are necessarily affiliated to one university or another (or they are constituent colleges of a university), they cannot directly confer degrees or diplomas on their own, but the students in those colleges are conferred by the university with which the given college is affiliated. As already mentioned, many research institutions (not institutions deemed to be universities and institutions of national importance) do not have powers to confer degrees on their own, but they can award diplomas and certificates.

8. ASSESSMENT OF HIGHER EDUCATION INSTITUTIONS

Once recognized by the UGC or the AICTE or a similar body, an institution (university or an institution deemed to be a university, college, or institution of national importance, or research institution) is expected to maintain a good standard and quality of education, and their degrees and diplomas are recognized throughout the country. No other assessment is made, except in the case of any specific problem. No ranking of the universities based on indicators of quality of education has ever been attempted, though the need for the same has been highlighted often by quite a few committees and commissions. There are, however, provisions for penal action or withdrawal of recognition of an institution if reasonable quality and standards are not maintained and/or if an institution is found involved in serious malpractices. But these provisions are rarely used. Of late, the National Assessment and Accreditation Council (NAAC) has been given a

greater responsibility for the proper accreditation of universities, colleges and other institutions of higher education based on sound objective criteria. By 2001, 161 institutions (mostly universities and colleges) were accredited and were given a star grade depending on the performance of the respective institution.

It may be interesting to note that unlike in a few other countries (e.g. Singapore), since there are no restrictions on the use of terms like school, college and even university, there are several unrecognized and non-accredited private institutions offering education and training programmes. Neither such institutions nor the diplomas offered by them are accredited by any agency.

Further, though some private institutions are recognized by the appropriate government bodies, it does not necessarily mean that all the courses they offer are officially recognized. It is possible that many courses they offer are not necessarily recognized by government or by government bodies. Instances of such institutions offering 'fake' degrees and cheating students are not rare.

On the whole, it may have to be stated that the present levels of regulatory mechanisms, mechanisms of recognition and mechanisms of assessment and accreditation are somewhat weak, and efforts are being made to strengthen the same.

9. DEGREES AND PROFESSIONAL COMPETENCE

Generally in most fields, a higher education degree is considered as a pre-requisite for (a) admission to further education and (b) employment in the formal labour market. In the case of employment in professional areas like medicine, law, engineering, architecture, accountancy, etc., this is more important. Generally, in most professional cases, additional training or internship/apprenticeship of about one year is necessary to obtain a license for practice. These licenses are issued by the co-ordinating agencies/bodies with which they are associated.

In the case of good employment, a degree from a higher education institution is increasingly becoming an essential pre-requisite. Even in the private sector and in the informal sector this is the case, though of a lesser extent. In the case of the public and the private sectors, degrees/diplomas are, however, only an essential pre-requisite. Most organisations offering employment conduct interviews and/or tests as well.

10. INTERNATIONAL RECOGNITION

Most of the universities and the institutions recognized by the UGC or by other authorized public agencies in India, are members of the Association of Commonwealth Universities. Besides, India is party to a few UNESCO conventions and there also exists a few bilateral agreements, protocols and conventions between India and a few countries on the recognition of degrees and diplomas awarded by the Indian universities. But many foreign universities adopt their own approach in finding out the equivalence of Indian degrees and diplomas and their recognition, just as Indian universities do in the case of foreign degrees and diplomas. The Association of Indian Universities plays an important role in this. There are no agreements that necessarily bind India and other governments/universities to recognize, en masse, all the degrees/diplomas of all the universities either on a mutual basis or on a multilateral basis.

Of late, many foreign universities and institutions are entering into the higher education arena in the country. Methods of recognition of such institutions and the courses offered by them are under serious consideration of the government of India. UGC, AICTE and AIU are developing criteria and mechanisms regarding the same.

Figure 1. Structure of Education in India

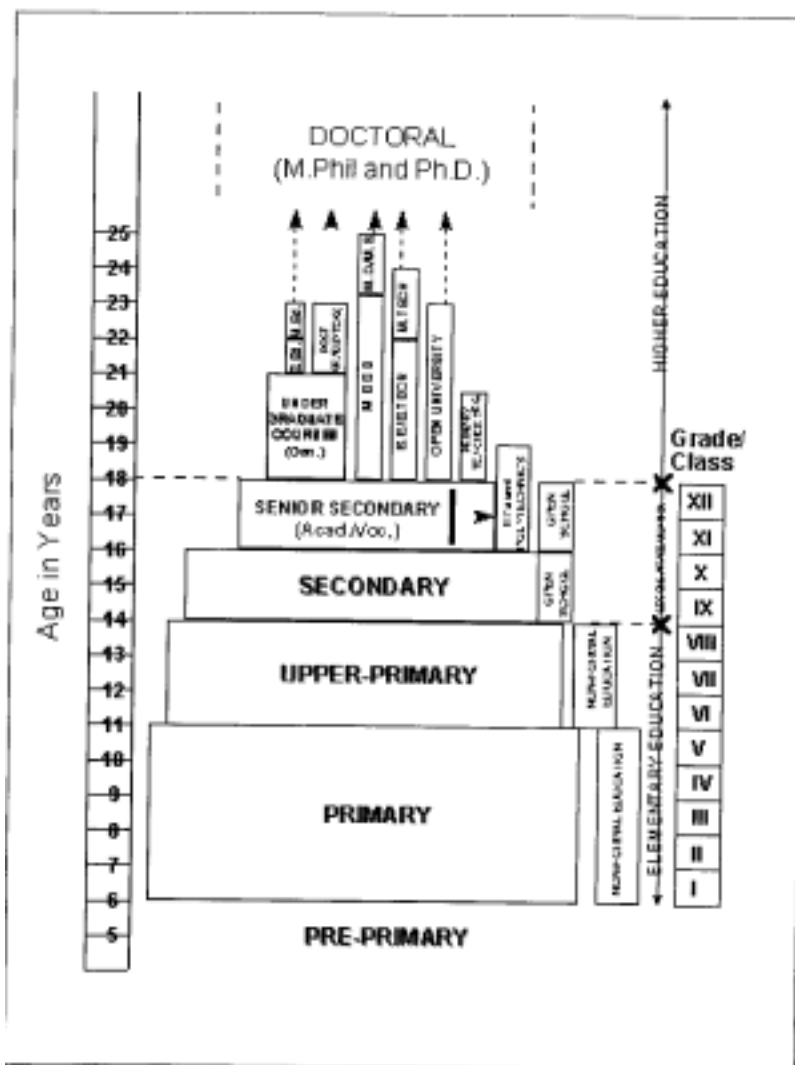
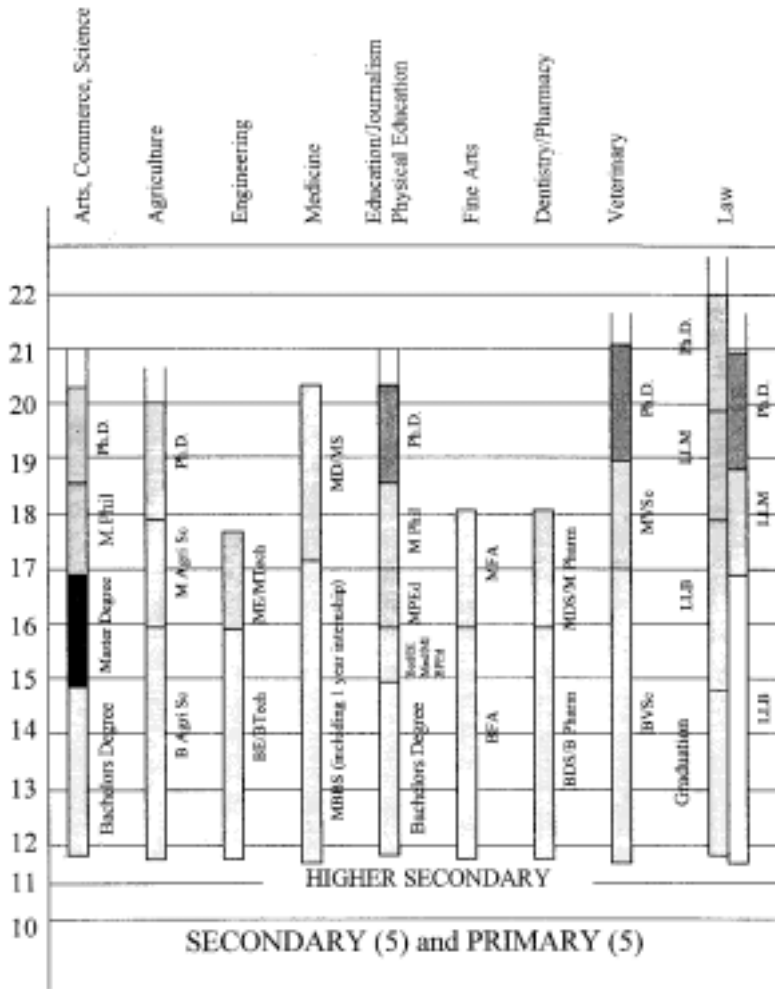

Figure 2. Structure of Higher Education in India



Annex 1

Higher Education Institutions in India, 2002-03	
Central Universities	18
Institutions deemed to be universities	76
State Universities	178
Institutions of national importance	12
Total Degree awarding Institutions	240
Colleges (Degree and above level)	13,150
<i>of which</i>	
Arts, Science and Commerce Colleges	7,926
Engineering and Technology Colleges	1,195
Medical Colleges	709
Teacher Training Colleges	833
Research Institutions	77
Other-Post Secondary Institutions	
Intermediate/Junior/Pre-Degree Colleges	4,631
Polytechnics	1,155

Source: UGC *Annual Report 2000-01* (New Delhi: UGC); *Selected Educational Statistics 2000-01* (New Delhi: Ministry of Human Resource Development) and *Annual Report 2002-03* (New Delhi: Ministry of Human Resource Development).

Annex 2

Universities and Other Institutions of Higher Education in India¹

Central Universities

Aligarh Muslim University
Assam University
Babasaheb Bhim Rao Ambedkar University
Banaras Hindu University
Central Agricultural University
University of Delhi
University of Hyderabad
Indira Gandhi National Open University
Jamia Milia Islamia
Jawaharlal Nehru University
Mahatma Gandhi Antar Rashtriya Hindi University
Maulana Azad National Urdu University
Nagaland University
North-Eastern Hill University
Pondicherry University
Tezpur University
Visva Bharati

Institutions deemed to be Universities (established under national legislation)

Allahabd Agricultural Institute
Avinash Lingam Institute for Home Sciences
Banasthali Vidyapith
Bengal Engineering College
Bharathi Vidyapeeth
Bhatkhande Institute of Hindustani Music
Bihar Yoga Bharati
Birla Institute of Technology
Birla Institute of Technology & Science
Central Institute of English & Foreign Languages
Central Institute of Fisheries Education
Central Institute of Higher Tibetan Studies
Dayalbagh Educational Institute
Deccan College Postgraduate & Research Institute
Dharmasinh Desai Institute of Technology
Forest Research Institute
Gandhigram Rural Institute
Gokhale Institute of Politics & Economics
Gujarat Vidyapith
Gurukula Kangri Vishwa Vidyalaya
Indian Agricultural Research Institute
Indian Institute of Sciences
Indian School of Mines

Indian Veterinary Research Institute
 Indian Institute of Information Technology
 Indira Gandhi Institute of Development Research
 Institute of Armament Technology
 International Institute for Population Sciences
 Jain Vishva Barati Institute
 Jamia Hamdard
 Lakshmbai National Institute of Physical Education
 Manipal Academy of Higher Education (private self-financing)
 National Dairy Research Institute
 National Institute of History of Art Conservation & Musicology
 National Institute of Mental Health & Neuro Sciences
 Rajasthan Vidyapith
 Rashtriya Sanskrit Vidyapith
 School of Planning & Architecture
 Shri Lal Bahadur Shastri Rashtriya Sanskrit Vidyapith
 Sri Chandra Sekharendra Saraswati Viswa Maha Vidyalyaya
 Sri Ramachandra Medical College & Research Institute
 Sri Sathya Sai Institute of Higher Learning
 Tata Institute of Social Sciences
 TERI School of Advanced Studies
 Thapar Institute of Engineering & Technology
 Tilak Maharashtra Vidyapith
 Vinayak Mission Research Foundation

Institutions of National Importance

All India Institute of Medical Sciences
 Indian Institute of Technology, Bombay
 Indian Institute of Technology, Delhi
 Indian Institute of Technology, Guwahati
 Indian Institute of Technology, Kanpur
 Indian Institute of Technology, Kharagpur
 Indian Institute of Technology, Madras
 Indian Statistical Institute
 Dakshina Bharat Hindi Prachar Sabha
 Post Graduate Institute of Medical Education & Research
 Sri Chitra Tirunal Institute of Medical Sciences & Technology

Institutions established under State legislation

Nizam's Institute of Medical Sciences
 Indira Gandhi Institute of Medical Sciences
 Sher-e-Kashmir Institute of Medical Sciences
 Sanjay Gandhi Postgraduate Institute of Medical Sciences
 SV Institute of Medical Sciences

State Universities

Dr B. R. Ambedkar University, Agra
 Alagappa University
 University of Allahabad
 Amravati University

Andhra University
Annamalai University
Arunachal University
Awadhesh Pratap Singh University
B. N. Mandal University
Babasaheb Bhim Rao Ambedkar Bihar University
Bangalore University
Barkatullah Vishwa Vidyalaya
Maharaja Sayajirao University of Baroda
Berhampur University
Bharathiar University
Bharathidasan University
Bhavnagar University
University of Mumbai
Bundelkhand University
University of Burdwan
University of Calcutta
University of Calicut
Ch Charan Singh University
Chitrakoot Gramodaya Vishwa Vidyalaya
Chatrapathi Sahuji Maharaj University
Deen Dayal Upadhaya Gorakhpur University
Devi Ahilya Vishwa Vidyalaya
Dibrugarh University
Dr Babasaheb Ambedkar Marathwada University
Dr Harisingh Gour Vishwa Vidyalaya
Dr Ram Manohar Lohia Awadh University
Dravidian University
Fakir Mohan
Guwahati University
Goa University
Guru Jambheshwar University
University of Gorakhpur
Gujarat University
Gulbarga University
Guru Ghasidas University
Guru Jambeswar
Guru Nanak Dev University
Guru Gobind Singh Indraprastha University
Hemvati Nandan Bahuguna Garhwal University
Himachal Pradesh University
Indira Kala Sangit Vishwa Vidyalaya
Jadavpur University
Jai Narian Vyas University
Jai Prakash Vishwa Vidyalaya
University of Jammu
Jiwaji University
Kakatiya University
University of Kalyani
Kameshwara Singh Darbhanga Sanskrit University

Kannada University
Kannur University
Karnatak University
Kashi Vidyapith
Kavi Kul Guru Kalidas Sanskrit University
University of Kashmir
University of Kerala
Kumaun University
Kurukshetra University
Kuvempu University
Lalit Narayan Mithila University
University of Lucknow
M J P Rohilkhand University
MP Bhoj University
University of Madras
Madurai Kamaraj University
Magadh University
Maharshi Dayanand Saraswati University
Maharshi Dayanand University
Maharshi Mahesh Yogi Vedic Viswa Vidyalaya
Mahatma Gandhi University
Mahatma Gandhi Gramoday Viswa Vidyalaya
Mahatma Gandhi Kashi Vidyapeeth
Makhan Lal Chaturvedi National University Institute of Journalism
Mangalore University
Manipur University
Manonmaniam Sundrananar University
Mohanlal Sukhadia University
MG Chitrakoot Gramoday
National Law School of India University
National Law Institute University
University of Mysore
Nagarjuna University
Nagpur University
National Academy of Legal Studies & Research
North Orissa University
University of North Bengal
North Gujarat University
North Maharashtra University
Osmania University
Panjab University
Punjabi University
Patna University
Periyar
Potti Sri Ramulu Telugu University
University of Pune
Pt Ravi Shankar Shukla University
Punjabi University
Purvanchal University
Rabindra Bharati University

Rajiv Gandhi Proudyogiki
University of Rajasthan
Ranchi University
Rani Durgavati Vishwa Vidyalaya
Rohilkhand University
University of Roorkee
Sambalpur University
Sampurnanand Sanskrit Vishva Vidyalaya
Sardar Patel University
Saurashtra University
Shivaji University
Shri Jagannath Sanskrit Vishva Vidyalaya
Siddu Kanhu University
South Gujarat University
Sree Sankaracharya University of Sanskrit
Sri Krishadevaraya University
Sri Venkateswara University
Swami Ramanand Teerth Marathwada University
Tamil University
Tamil Nadu Dr Ambedkar Law
Tilka Manjhi Bhagalpur University
Tripura University
Utkal University
Utkal University of Culture
VBS Poorvanchal
Veer Kunwar Singh University
Vidyasagar University
Vikaram University
Vinoba Bhave University

Open Universities

Indira Gandhi National Open University (central university)
Dr B.R. Ambedkar Open University, Hyderabad
Dr Babasaheb Ambedkar Marathwada Open University
Karnataka State Open University
Kota Open University
Y.R.C. Maharashtra Open University
Madhya Pradesh Bhoj University
Nalanda Open University
Netaji Subash Open

Agricultural Universities (State level)

Acharya Ranga Agricultural University
Allahabad Agricultural Deemed University
Assam Agricultural University
Bidhan Chandra Krishi Vishva Vidyalaya
Birsra Agricultural University
Chandra Shekhar Azad University of Agriculture & Technology
Ch Charan Singh Haryana Agriculture University
Central Agricultural

Central Institute of Fisheries Education
 Dr Punjab Rao Deshmukh Krishi
 Govind Ballabh Pant University of Agriculture of Technology
 Gujarat Agricultural University
 Himachal Pradesh Krishi Vishwa Vidyalaya
 Indian Veterinary Research Institute
 Indira Gandhi Krishi Vishwa Vidyalaya
 Jawaharlal Nehru Krishi Vishwa Vidyalaya
 Kerala Agricultural University
 Konkan Krishi Vidyapith
 Maharana Pratap University of Agriculture & Technology
 Mahatma Phule Krishi Vidyapith
 Marathwada Krishi Vidyapith
 National Dairy Research Institute
 Narendra Deva University of Agriculture & Technology
 Orissa University of Agriculture & Technology
 Punjab Agricultural University
 Punjabrao Kirishi Vidyapith
 Rajasthan Agricultural University
 Rajendra Prasad Agricultural University
 Sher-e-Kashmir University of Agricultural Sciences & Technology
 Tamil Nadu Agricultural University
 Tamil Nadu Veterinary & Animal Sciences University
 University of Agricultural Sciences, Bangalore
 University of Agricultural Sciences, Dharwad
 West Bengal University of Animal & Fisheries Sciences
 Dr Y.S. Parmar University of Horticulture & Forestry

Technological Universities (State level)

Anna University
 Cochin University of Science & Technology
 Dr. Babasaheb Ambedkar Technological University
 Jawaharlal Nehru Technological University
 Punjabi Technical University
 University of Roorkee
 Visveswaryya Technological

Medical Universities (State level)

Gujarat Ayurved University
 Maharashtra University of Health Sciences
 NTR University of Health Sciences
 Postgraduate Institute of Medical Education & Research
 Rajiv Gandhi University of Health Sciences, Karnataka
 Sikkim-Manipal University of Health, Medical & Technological
 Sciences
 Sree Chitra Tirunal Institute for Medical Sciences & Technology
 Sri Ramachandra Medical College & Research Institute
 Sri Venkateswara Institute of Medical Sciences
 Tamil Nadu Dr. M.G.R. Medical University
 University of Health Sciences Andhra Pradesh

Women's Universities

Avinashilingam Institute for Home Science & Higher Education for
Women (Institute deemed to be a university)
Lakshmbai National Institute of Physical Education
Mother Teresa Women's University
Shreemati Nathibai Damodar Thackerey Women's University
Sri Padmavati Mahila Visva Vidyalyaya

Source: *Annual Report 2002-01* (New Delhi: UGC) and *Universities Handbook* (29th Edition).
New Delhi: Association of Indian Universities, 2002.

Annex 3

Degrees and Diplomas Awarded by Indian Universities

Arts (including Fine Arts), Humanities and Social Sciences*Degrees*

BAA	Bachelor of Applied Arts
BA (Ed Deaf)	Bachelor of Arts (Education of the Deaf)
BA	Bachelor of Arts
BA(Hons)	Bachelor of Arts (Honours)
BArt	Bachelor of Art
BA(Mus)	Bachelor of Arts in Music
BA(Rs)	Bachelor of Arts (Rural Studies)
BA(Spl)	Bachelor of Arts (Special)
BD	Bachelor of Dramatics
BDance	Bachelor of Dance
BFA/Bfine	Bachelor of Fine Arts
BMus	Bachelor of Music
BLitt	Bachelor of Literature
BOL	Bachelor of Oriental Learning
BPA	Bachelor of Performing Art
BRI	Bachelor of Religions of India
BRS	Bachelor of Rural Studies
BSAS	Bachelor of Sanskrit & Applied Arts
BSSC	Bachelor of Social Science
BSW	Bachelor of Social Work
BTA	Bachelor of Theater Arts
BTh	Bachelor of Theology
BVA	Bachelor of Visual Arts
DLitt	Doctor of Literature
DMus	Doctor of Music
DOL	Doctor of Oriental Learning
DPhil	Doctor of Philosophy
DSc	Doctor of Science
DTh	Doctor of Theology
IA	Intermediate in Arts
ICom	Intermediate in Commerce
ISc	Intermediate in Science

Inter	Intermediate
MA	Master of Arts
MA (Fine)	Master of Arts (Fine Arts)
PUC	Pre-University Course
PhD	Doctor of Philosophy
MRS	Master of Rural Studies
MSW	Master of Social Work
MTh	Master of Theology
MOL	Master of Oriental Learning
MPA	Master of Performing Arts
MLitt	Master of Literature/ Mater of Letters
MMus	Master of Music
MDance	Master of Dance
MAS	Master of Applied Sociology
MFA/MFine	Master of Fine Arts

Diplomas

DSS	Diploma in Social Service
DUG&A	Diploma in Urban Government and Administration

Medicine*Degrees*

MD	Doctor of Medicine
MD (Ay)	Doctor of Medicine (Ayurvedic)
Msc (Med)	Master of Science (Medicine)
BAM	Bachelor of Ayurvedic Medicine
BHMS	Bachelor of Homeopathic Medicine and Surgery
BMRSc	Bachelor of Medical Research Science
BSAM	Bachelor of Shuddha Ayurvedic Medicine
BSc (Med)	Bachelor of Science in Medicine
BSc (Mining)	Bachelor of Science in Medicine
BUMS	Bachelor of Unani Medicine and Surgery
BUTS	Bachelor of Unani Tib & Surgery
BUMMS	Bachelor of Unani Medicine with Modern Medicine and Surgery
DAyM	Doctor of Ayurvedic Medicine
DHy	Doctor of Hygiene
DM	Doctor of Medicine
DMA	Doctor of Ayurvedic Medicine
DUM	Doctor of Unani Medicine
GHMS	Graduate in Homeopathic Medicine and Surgery
IPham	Intermediate in Pharmacy
MASc	Master of Ayurvedic Science
MAyM	Master of Ayurvedic Medicine
MBBS	Bachelor of Medicine and Bachelor of Surgery
MBS (Homeo)	Bachelor of Medicine & Surgery (Homeopathy)
MDS	Master of Dental Surgery
MS	Master of Surgery
BDS	Bachelor of Dental Surgery
BPharm	Bachelor of Pharmacy

BPhysio	Bachelor of Physiotherapy
BPhT	Bachelor of Physio Therapy
BSc (Nursing)	Bachelor of Science in Nursing
BSc (OT)	Bachelor of Science (Occupational Therapy)
BSc (PT)	Bachelor of Science (Physical Therapy)
BThO	Bachelor of Occupational Therapy
BMS (Homeo)	Bachelor of Medicine & Surgery (Homeopathy)
MPharm	Master of Pharmacy
MCH	Master of Community Health
MO	Master of Obstetrics

Diplomas

AMD	Diploma in Aviation Medicine
DA	Diploma in Anesthesia
DAM	Diploma in Sayurvedic Medicine
DCD	Diploma in Chest Diseases
DCH	Diploma in Child Health
DCP	Diploma in Clinical Pathology / Diploma in Clinical Psychology
DCPM	Diploma in Clinical Pathology & Microbiology
DD	Diploma in Dermatology
DDM	Diploma in Dermatological Medicine
DDR	Diploma in Diagnostic Radiology
DD&STD	Diploma in Dermatology and Sexually Transmitted Diseases
DDVD	Diploma in Dermatology and Venereal Diseases
DE	Diploma in Embryology
DFM	Diploma in Forensic Medicine
DFP	Diploma in Family Planning
DGO	Diploma in Gynecology and Obstetrics
DMRIT	Diploma in Medical Radio Isotope Techniques
DMLT	Diploma in Medical Laboratory Technology
DMP	Diploma in Medical Psychology
DMPB	Diploma in Medical Pathology and Bacteriology
DMR	Diploma in Medical Radiology
DMRD	Diploma in Medical Radio-Diagnosis
DMRE	Diploma in Medical Radiology and Electrology
DMRT	Diploma in Medical Radiation Therapy
DO	Diploma in Ophthalmology
DOOrth/ DOrtho	Diploma in Orthopaedics/Diploma in Orthopaedic Surgery
DOMS	Diploma in Ophthalmic Medicine and Surgery
DPaed	Diploma in Paediatrics
DPH	Diploma in Public Health
DPM	Diploma in Psychological Medicine / Diploma in Psychiatric Medicine
DPM&R	Diploma in Physical Medicine & Rehabilitation
DSTD	Diploma in Sexually Transmitted Diseases
DTCD	Diploma in Tuberculosis & Chest Diseases
DTM&H	Diploma in Tropical Medicine & Hygiene

DV	Diploma in Venereology
DV&D	Diploma in Venereology & Dermatology
DM&CW	Diploma in Maternity and Child Welfare
DMCH	Diploma in Maternity & Child Health
DLO	Diploma in Laryngology and Otology
PPC	Pre-Professional Course

Engineering, Technology & Architecture

Degrees

ME	Master of Engineering
MS (Agril Engg)	Master of Science (Agriculture Engineering)
MSc (Engg)	Master of Science (Engineering)
BCE	Bachelor of Civil Engineering
BChE	Bachelor of Chemical Engineering
BE	Bachelor of Engineering
BEE	Bachelor of Electrical Engineering
BE (Elect)	Bachelor of Engineering (Electrical)
BE (Mech)	Bachelor of Engineering (Mechanical)
BE (Meta)	Bachelor of Engineering (Metallurgy)
BE (Mining)	Bachelor of Engineering (Mining)
BE (Tele-Com)	Bachelor of Engineering (Tele-Communication)
BE & Tele	Bachelor of Electronics and Tele – Communication Engineering
BME	Bachelor of Mechanical Engineering
BMet	Bachelor of Metallurgy
BSc (Agrl Engg)	Bachelor of Science in Agriculture Engineering
BSc (Engg)	Bachelor of Science in Engineering
BSc (Min Engg)	Bachelor of Science in Mining Engineering
BText (Engg)	Bachelor of Textiles (Engineering)
BText (Tech)	Bachelor of Textiles (Technology)
DEngg	Doctor of Engineering
BSc (Tech)	Bachelor of Science (Technology)
BSc (Text)	Bachelor of Science (Textiles)
BTech	Bachelor of Technology
BTech (NA)	Bachelor of Technology (Naval Architecture)
BText	Bachelor of Textiles
BArch	Bachelor of Architecture
MSc (Food & Tech)	Master of Science in Food & Technology
MSc (Tech)	Master of Science (Technology)
MTech	Master of Technology
MCP	Master of City Planning
MTP	Master of Town Planning
MTCP	Master of Town and Country Planning
MCRP	Master of City & Regional Planning
MURP	Master of Urban and Regional Planning
MRP	Master of Regional Planning

Diploma

DME	Diploma in Mechanical Engineering
-----	-----------------------------------

Agriculture, Veterinary*Degrees*

BFSc	Bachelor of Fishery Science
BVAsC	Bachelor of Veterinary Animal Science
BVSc	Bachelor of Veterinary science
BVSc&AH	Bachelor of Veterinary Science and Animal Husbandry
BSc (Vet)	Bachelor of Science (Veterinary)
BSc (Ag)	Bachelor of Science in Agriculture
BScAg&AH	Bachelor of Agricultural and Animal Husbandry
BSc (Hort)	Bachelor of Science (Horticulture)
MVSc	Master of Veterinary Science
MSc (Ag)	Master of Science (Agriculture)
MFSc	Master of Fisheries Science

Education/Teacher Education*Degrees*

BAdED	Bachelor of Adult Education
Edn (Hons)	Education (Honours)
BT	Bachelor of Teaching
DE, Ded	Doctor of Education
MCT	Master of College Teaching
MHEd	Master of Higher Education
MEd	Master of Education

Diplomas/ Certificates

TD	Diploma in Teaching
TTE	Training for Teaching English
TTG	Training of Teachers in Geography

Law*Degrees*

BAL	Bachelor of Academic Laws
BGL	Bachelor of General Laws
BIL	Bachelor of Industrial Laws
BL	Bachelor of Laws
BSL	Bachelor of Social Law
DL	Doctor of Laws
BCL	Bachelor of Civil Laws
DCL	Doctor of Civil Laws
LLB	Bachelor of Laws
LLD	Doctor of Laws
LLM	Master of Laws

Commerce & Business Management / Administration*Degrees*

BBA	Bachelor of Business Administration
BBM	Bachelor of Business / Band Management
BBS	Bachelor of Business Studies
BHM	Bachelor of Hotel Management

BHRD	Bachelor of Human Resource Development
BHRM	Bachelor of Human Resource Management
BCom	Bachelor of Commerce
MIB	Master of International Business
MBE	Master of Business Economics
MIRPM	Master of Industrial Relations & Personnel
MAMM	Master of Agricultural Marketing Management
MAPRM	Master of Advertising And Public Relation Management
MBA	Master of Business Administration
MBF	Master of Business Finance
MBM	Master of Business Management
MBS	Master of Business Statistics
MCSMM	Master Degree in Chemical Sales & Marketing Management
MFA/MFine	Master of Financial Administration
MFAM	Financial & Agricultural Management
MFC	Master of Finance & Control
MMS	Master of Management Studies
MMSc	Master of Management Science
MTA	Master of Tourism Administration
Mcom	Master of Commerce
MLS	Master of Labour Studies
MLW	Master of Labour Welfare
MDRDM	Master degree in Rural Development & Management

Diplomas

DBA	Diploma in Business Administration
DBM	Diploma in Business Management
DIH	Diploma in Industrial Health
DHA	Diploma in Hospital Administration
DPA	Diploma in Public Administration
DLW	Diploma in Labour Welfare

Computer Sciences*Degrees*

BCA/BCs	Bachelor of Computer Application/Sciences
BCS	Bachelor of Corporate Sciences
MCA	Master of Computer Applications
MCEd	Master of Computer Education

Library Sciences*Degrees*

BLISc/BLIS	Bachelor of Library and Information Science
BLSc/BLib/BLibSc	Bachelor of Library Science / Master of Library & Information Science
MLISc/MLIS	Master of Library and Information Science

Diploma

DLSc	Diploma in Library Science
------	----------------------------

Journalism*Degrees*

BCJ	Bachelor of Communication & Journalism
BJ	Bachelor of Journalism
BJC	Bachelor of Journalism & Communication
BJ&MC	Bachelor of Journalism & Mass Communication
BMCJ	Bachelor of Mass Communication & Journalism
MCJ	Master Communication & Journalism
MCS	Master in Communication Science
MJ	Master of Journalism
MJ&MC	Master of Journalism & Mass Communication
MSC	Master in Social Communication

Diploma

JD	Diploma in Journalism
----	-----------------------

Physical Education*Degrees*

BNYS	Bachelor of Naturopathy & Yogic Science
BPE, BPEd	Bachelor of Physical Education
BPES	Bachelor of Physical Education & Sports
BYS	Bachelor degree in Yogic Sciences
MPE/ MPEd	Master of Physical Education
MPES	Master of Physical Education & Sports Sciences
MPM	Master of Physical Management
BSSc	Bachelor of Sports Sciences

Diploma

DHE	Diploma in Health Education
DPH/DPEd	Diploma in Physical Education Natural Sciences

Degrees

BS	Bachelor of Science
BSc	Bachelor of Science
BSc (Home Art)	Bachelor of Science (Home Art)
BSc (HomeEco)	Bachelor of Science (Home Economic)
BSc (Home Sc)	Bachelor of Science (Home Science)
BSc (Hons)	Bachelor of Science (Honours)
BHSc	Bachelor of Home Science
MHSc	Master of Home Science
MSc	Master of Science
MCh	Master of Chirurgy

1. COUNTRY PROFILE

Indonesia is a country made up of about 17,000 islands stretching across some 3,200 miles of equatorial ocean situated in Southeast Asia. In the North, it borders the Andaman Sea, Singapore, the South China Sea, Malaysia, the Philippines and the Pacific Ocean. In the East, it borders Papua New Guinea; in the South it borders the Indian Ocean. Approximately 5.3 million square miles of the Indonesian territory is water, which is approximately 81 per cent of the national territory. Indonesia is therefore known as a maritime nation.

Indonesia is the fourth most populous country after the People's Republic of China, India and the United States. According to the population census of 1990, Indonesia had 179.3 million citizens. The annual population growth in the period of 1980-1990 was 1.97 per cent. In 1995, the population stood at 195.7 million, with population growth as low as 1.82 per cent in the period of 1990-1995. The population growth has decreased compared with the previous decade (1971-1980) during which was 2.32 per cent. The decrease is mainly due to the success of family planning programmes.

2. NATIONAL DEVELOPMENT AND EDUCATION

At the beginning of 1994/1995 all the way up to 2018/2019, Indonesia has been entering into the Second 25-year Long-term Development Plan/PJP II (1994/1995) as the most determining phase, also known as *the take-off* era. The most significant nature of PJP II is the strong emphasis on human resources development (HRD).

The emphasis on human resource development which appears in all sectors and sub-sectors of the national development is testimony that Indonesia has made a strong commitment to attain excellence in mastering science and technology to equal other nations in the world. The Government is aware of the role of quality human resources in mastering science and technology as a governing factor in achieving excellence.

The improvement of education and culture in PJP II should be more reactive towards the numerous transformations and should be able to seize the various existing opportunities to produce Indonesian human resources who are capable of sustaining national development. Therefore, efforts to improve the education system in PJP II face several challenges. These challenges will become evident, particularly in implementing the nine-year universal basic education programme, and equitable administration of higher quality secondary education. The underlying idea, is that graduates will be more able to continue studies at universities, or enter the mid-level labor force in line with development needs, either through their knowledge and skills, or their relevant needs.

The role of technology in supporting economic and industrial growth as well as development in all other sectors will be more important in PJP II. The development strategy which

relies more on natural resources is no longer appropriate, due to the finite nature of natural resources as an economic engine. Development should rely more on human resources who are capable of generating and engineering technology. Therefore, all of these require improvement of human resources in science and technology through more strategically developed education.

As the main issues reside in human resources development, the Ministry of National Education (MOEC) is accountable in the framework of national education development for the improvement of human resources quality. For this reason, it is critical for MOEC to apply numerous policies on education that will address the above challenges. The development of national education and culture cannot be separated from elements that affect economic development. Various studies indicate that among the significant elements, the population and labor force possess close association with the development effort of the national education and cultural systems.

Future challenges

The structural shift of the economy, labour force, science and work skill, generates numerous trends and challenges which in turn affect the education system of the future. Among those are: (a) the importance of value-added orientation, (b) changes in social structure, and (c) effect of the globalization process.

The first challenge, the value-added orientation, is a great necessity to enhance the national productivity levels and economic growth as a means to maintain and improve further overall social development. The value-added orientation to increase the competitiveness of the Indonesian people can only be achieved by creating superior quality human resources who have mastered science and technology effectively, and have begun to adapt to a national industrial culture.

The second challenge is the transformation process from agricultural to industrial society. This is one of the indicators that the take-off process in our national development is taking place. The transformation transpires as a consequence of the rise of the industrial sector which is revealed by the emergence of new and various kinds of positions which require innovative skills and expertise that are conducive to the advancement of science and technology. The various kinds of new positions and expertise also cause changes in the physical and social structure and accompanying shifts in the value system.

The third challenge confronted by the Indonesian people is the globalization process. The massive and extensive globalization which affects political and economic conditions and which is influenced by international socio-cultural limitations is still a hazy concept. Globalization is expected to generate intensified competition among nations, particularly in the fields of economies as well as science and technology. Only nations that excel in the areas of economics and technology can utilize this great opportunity of globalization. Supremacy in the field of economy and technology can primarily be achieved by the quality of human resources. When the quality of our human resources is low, numerous opportunities cannot be optimally utilized and will be wasted. From the national perspective, globalization creates a perception that we are citizens of a global society and can therefore, take benefit from it. From another perspective there is a thrust to preserve and strengthen the national identity. These two perceptions are neither contradictory nor optional, but are complementary to each other.

3. NATIONAL EDUCATION SYSTEM

According to Law No. 20/2003 on the National Education System, the objectives of the national education development are to develop the learners' abilities and the national character and

civilization with dignity in aiming at making the life of the nation intelligent, developing the learners' potential in order to become human beings with belief and piety to God, to have noble conduct, to be healthy, knowledgeable, skillful, creative, independent, democratic and responsible citizens.

Overview of education development

The development of national education has been given the top priority in national development. This commitment is in accordance with the 1945 constitution which stipulates in Article 31 that (a) every citizen has the right to obtain education, and (b) the government provides one national education system which is arranged by law. Moreover, the provision appears in the National Guidelines of the State Policy (GBHN) and in Education Law No. 20/2003, which provide direction to the government in its national development efforts and its guidance of the national education system.

The development of human resources, through the provision of equal distribution of learning opportunities, has experienced fast progress since Indonesia's independence in 1945, when less than 6 per cent of the population of Indonesia was literate. In 1951 this percentage increased to 20 per cent. In 1985, 81 per cent of the population older than 10 years of age was literate. The population census of 1990 indicates that 84.1 per cent of the population older than 10 years of age are literate. This shows the success of the development in the education sector in particular of primary education, which has developed fast in the 25 years following the pre-independence period, and even faster during the First 25-Year Long-Term Development Plan.

More and more school-age children and youths are going to schools or attending out-of-school education programmes. The education statistics show that the number of students at every level of the school system has grown extremely fast within the last 25 years. During that period, the number of school students rose more than double (206 per cent) for primary school, four-and-a-half-fold, (451 per cent) for the junior secondary school, eight times (803 per cent) for the senior secondary schools, and about 10 times (per cent) for the higher education. This reality of education will gradually change a great deal the structure of the labor force of Indonesia.

Another example of success achieved is the expansion and balanced distribution of educational opportunities at primary schools. This effort has been on its way since 1973, when large numbers of new schools began to be built through the Presidential Decree Programme for primary schools (INPRES SD). This achievement enabled the government to make basic primary education compulsory from 1984.

Today, the compulsory basic education programme has yielded large numbers of primary school graduates. Most of them are 12 years of age and according to the Labor Law they cannot yet be categorized as members of the productive work force. The number of school drop-outs is still high. Eventually, primary school drop-outs and primary school graduates will be unemployed because they do not have enough skills required to do productive work particularly in industrial sectors of the economy. Having planned to establish an industrial society, Indonesia needs to enhance skills and productivity of the basic education graduates to become productive industrial workers. For such a reason, the number of years of compulsory basic education is extended to 9 years, adding three years of schooling for those of 12-15 years of age. The curriculum of the junior secondary school is also expanded with skills training, especially for students who are not able to continue to senior secondary education.

Keeping in mind that the resources available for the implementation of universal basic education are limited, the role of the community and parents in providing 9 years of basic education is important. Madrasah Ibtidaiyah (Islamic Primary School), Madrasah Tsanawiyah (Islamic General Junior Secondary School), private and public schools of primary and junior secondary all play an equally important role in providing basic education.

Religious education is considered important in the development of human resources quality. Therefore, the government has subsidized the private madrasah schools a great deal in terms of building, teachers, and operational cost. Besides maintaining religious content the academic subjects' contents have also been expanded in the madrasah school's curriculum, reaching the level taught in the regular basic education system.

In order to support the programme of compulsory 9-year basic education, out-of-school education has also a very important role to play. In addition to elimination of illiteracy, it also provides an education equivalent to primary and junior secondary school. Therefore, school and out-of school education are mutually supportive in aiming at providing a 9-year basic education opportunity.

Within the context of improving the quality of human resources, the government's programme related sectors, aiming at equity and equality improvement, have been well integrated. During the First 25-year Long-Term Development Plan period, the government was able to meet the basic needs of people in terms of food, clothing and housing. The industrial and agricultural sectors continue to develop so as to provide more employment opportunities. Education and health care have been made available to virtually all. Indonesia is therefore well placed to provide further education opportunities to its people and thereby enhance the skills and qualities of its human resources.

National education is aimed at improving the intellectual life of the nation, and developing the Indonesian people fully, i.e., people who are devoted to God, who have knowledge and skills, who are in good physical and spiritual health, who are independent and fair, and who feel responsible for their countrymen and nation.

National education also strives to create a patriotic spirit, strengthen love for the fatherland, enhance national spirit, social solidarity and awareness of national history, instill honor for the national heroes, and create a forward-looking attitude.

The learning and teaching climate has to generate self-confidence and a learning culture at all layers of society that induces an attitude and behavior of creativity, innovative thinking, and orientation towards the future.

Overview of the education system

The national education system has its roots in Indonesian culture. The system based on Pancasila, the 1945 State Constitution, and Law No. 20/2003 about the national education system, aims to generate abilities and to increase the standard of living and dignity of the Indonesian people in order to achieve the national development objectives. According to Law No. 20/2003, the national education system is identified in terms of units, paths, types, and levels of education.

The units of education

A unit of education (school or out-of-school) organizes learning and teaching activities which are implemented within and outside the formal school system as well.

The paths of education

The education system recognizes two different education paths, i.e., school and out-of-school education. School education is organized in schools through teaching and learning activities which are gradual, hierarchical, and continuous. Out-of-school education is organized outside the formal schooling through teaching and learning activities which do not have to be hierarchical and continuous. Education in the family as an important part of the national education system (out-of-school education) functions in providing religious, cultural and moral values and skills.

Types of education

The national education system (school as well as out-of-school) consists of seven types of education, they are: (a) *general education* which prioritizes expansion of general knowledge and improvement of skills for the students. Specialization is also needed in the last grade; (b) *vocational education* which prepares students in mastering a number of specific vocational skills needed for employment; (c) *special education* which provides important skills and abilities for students with physical and/or mental disabilities; (d) *service related education* which aims at increasing abilities required as a job preparation for an official or a civil servant candidate for a government department or non-department government agency to implement a certain task; (e) *religious education* which prepares students to play a role which demands the mastering of specific knowledge about religion and related subjects; (f) *academic-oriented education* which focuses primarily on improving mastery of sciences; and (g) *professional education* which prepares students primarily to master specialized or job related knowledge and skills.

Age	Yr	Stages	Level	In-School						Out-of-School
27	21	Doctorate	Higher Education	I	n	S3				OPEN UNIVERSITY
26	20									
25	19									
24	18	Master's		i	S2					
23	17									
22	16	Under-graduate		e	S1	P	O	A	D3	
21	15									
20	14									
19	13									
18	12	3		Secondary Education	G	V	R	O	S	
17	11	2								
16	10	1								
15	9	3								
14	8	2	Basic Education	Junior Secondary School						Package B Programme
13	7	1								
12	6	6								
11	5	5		Primary School						Package A Programme
10	4	4								
9	3	3								
8	2	2								
7	1	1	K i n d e r - g a r t e n	Pre-school						
6		0A								
5		0B								

<i>SMU</i>	=	<i>Sekolah Menengah Umum</i>
<i>SMK</i>	=	<i>Sekolah Menengah Kejuruan</i>
<i>SMKd</i>	=	<i>Sekolah Menengah Kedinasan</i>
<i>SLB</i>	=	<i>Sekolah Luar Biasa</i>
<i>MA</i>	=	<i>Madrasah Aliyah</i>

Levels of education

The formal school system consists of the following levels of education: basic education, secondary education, and higher education. Apart from the levels of education mentioned above, pre-school education is also provided.

Pre-school Education

Pre-school education is aimed at stimulating physical and mental growth of pupils outside of the family circle before entering primary education.

The objective of pre-school education is to provide an early basis for growth and development of attitudes, knowledge, skills and initiative.

Among the types of pre-school education available are kindergarten and play groups. Kindergartens are part of the school-based education system while the play groups are part of the out-of-school system. Pre-school is provided for children from 4 to 6 years old for a one to two years period of education, while play groups are attended by children of 3 years and below.

Among the most important subjects taught in kindergarten are:

- The moral Pancasila
- Religion
- Discipline
- Language skills
- Intellectual stimulation
- Creativity
- Emotional harmony
- Social skills and physical ability

SCHOOL SYSTEM IN INDONESIA

Official School Age		Academic Education		Professional Education		
		Islamic	General	Professional	Diploma	Diploma
22	Higher Education	Islamic Doctorate Programme	Doctorate Programme	Professional Programme		
21		Islamic Master's Programme	Master's Programme	Professional Programme		
20		Islamic Graduate Programme	Graduate Degree Programme	Diploma 4 Programme	Diploma 3 Programme	
19					Diploma 2 Programme	Diploma 1 Programme
18	Secondary Education	Islamic SSS		General SSS		Vocational SSS
17						
16						
15	Basic Education	Islamic SSS		General SSS		
14						
13						
12						
11						
10		Islamic School	Primary	Primary School		
9						
8						
7						
6	Pre-School	Islamic Kindergarten		Kindergarten		
5						

Over the years since 1969, kindergartens have increased in terms of total number of school buildings, students and teachers. This shows that the community has become aware of the importance and strategic role of pre-school as a tool in the improvement of attitude, knowledge, skills and mental creativity of young children.

Basic Education

Basic education is in principle a general education of nine years, consisting of six years of primary school education and three years of junior secondary education. The goal of basic education is to provide the students with basic skills to develop themselves as individuals, members of society, citizens and members of mankind, as well as to prepare them to pursue their studies in secondary education.

Primary school provides six-year primary education programmes. It consists of two different types of education, i.e., general primary school (SD), and special primary school for handicapped children (SDLB).

Junior secondary school programmes organize a three-year education programme after the six-year primary school programme. It consists of two different types of education, i.e., junior secondary (general), and special junior secondary school (for handicapped children).

In addition to the types of education above, there is also an Islamic Primary School administered by the Ministry of Religious Affairs. The Islamic Primary School (Madrasah Ibtidaiyah or MI) is equivalent to primary school (SD), and the Islamic Junior Secondary School (Madrasah Tsanawiyah or MTs) is equivalent to junior secondary school (SLTP).

At the beginning of the fourth period of the Five-Year Development Programme (1984) the government of Indonesia implemented a six-year compulsory education for primary school age children (7-12 years). The result of this new policy was significant, the participation rate in primary school sped up to the level of 92.16 in 1993 compared to 79.3 per cent in 1983. Currently, the programme has been extended to the 13-15 year-old population (Junior Secondary School) since it was proclaimed by then President Soeharto on May 2, 1994. The policy, then, has been recognized as *Wajar Dikdas 9 tahun* (Compulsory Nine-year Basic Education). The compulsory nine-year basic education is meant to give ample opportunities to Indonesian citizens to get basic education. In this connection, the extension from six to nine years of basic education is also intended to alleviate the problem of child labor and to keep children in school up to the point that they are able to keep up with the changing demands of their society, especially for those who cannot afford to pursue a higher level of education.

The core content of basic education curriculum consists of: Pancasila (state ideology), religion, civic education, Indonesian language, reading and writing, mathematics (including arithmetic), introduction to sciences and technology, geography, national and world history, handicrafts and art, physical and health education, drawing, English, and local content. They are not the names of subject matters, but are more in terms of studies to form personality and elements of ability which are taught and enhanced through basic education. More than one element may be combined into one subject matter or, the other way around, one element may be developed into more than subject matter.

At the initial stage, the new 1994 basic education curriculum was implemented stepwise starting in 1994-1995 academic year with grade one and grade four of primary school. In the 1995-1996

academic year, it was increased to grade two and five, and the curriculum was fully implemented in the 1996-1997 academic year. Likewise, at the Junior Secondary level the new curriculum was initially implemented at grade one in 1994-1995 academic year, grade one and grade two in 1995-1996, and all grades in 1996-1997.

The number of primary schools has grown rapidly since 1974, when the INPRES-SD programme was started to build primary schools throughout the country. Likewise, the number of junior secondary schools increased significantly from 1969 to 1995-1996.

Secondary Education

Secondary education is available to graduates of basic education. The objectives of secondary education are:

- (a) to develop students' knowledge to continue their studies to higher levels of education and to develop themselves in accordance with the development of science, technology and arts; and
- (b) to develop students' ability as members of the society to interact with their social, cultural and natural environment.

The types of secondary education include general secondary school, vocational secondary school, religious secondary school, service secondary school, and secondary school.

- General secondary education gives priority to expanding knowledge and developing students' skills and preparing them to continue their studies to the higher level of education.
- Vocational secondary education gives priority to expanding specific occupational skills and emphasizes the preparation of students to enter the world of work and expand their professional attitude.
- Religious secondary education gives priority to the mastery of special religious knowledge.
- Service secondary education is education which emphasizes improving the ability in the execution of service tasks of civil servants or candidates for civil service.
- Special secondary education is especially intended and designed for physically and/or mentally disabled students.

General Secondary Education

General Secondary Education consists of two different types of education, i.e.; General Secondary School, and Madrasah Aliyah (Islamic Senior Secondary School).

The curriculum of general secondary education consists of general and specific teaching programmes. The general education programme is implemented in the 1st and 2nd grades, while the specific teaching programme starts to be implemented in the 3rd grade.

The curriculum for the general secondary education is implemented in phases; in the 1995-1996 academic year with the 1st and 2nd grade; and in the 1996-1997 academic year covering all grades (1st-3rd grades) of the senior secondary education. By the end of Repelita VI at the latest, the whole curriculum of the general secondary school will be fully implemented.

Vocational Secondary Education

A unit of education which organizes vocational secondary education is called vocational secondary school. The vocational secondary education programmes are classified into six different groups of vocational fields:

- Agriculture and Forestry,
- Technology and industry,
- Business and Management,
- Community Welfare,
- Tourism, and
- Arts and Handicraft.

The implementation of vocational education is based on the national curriculum and adjusted to the local and environmental needs, and distinctive features of the concerned vocational education.

The curriculum of vocational secondary school consists of general and vocational education programmes.

The general programme consists of a number of compulsory normative subject matters aiming at molding the character and personality of students. The general programme consists of the following subjects:

- Pancasila and Civic Education,
- Religious Education,
- Indonesian Language and Literature,
- Physical and Health Education, and
- National and World History.

The vocational programme that composes basic and professional vocational subject matters aims at forming an ability to develop and adapt in accordance with the development of science, technology and arts. The professional subjects aim at generating a productive ability to be applied in the concerned field of work.

During the first 25-year long-term development period, secondary education had grown rapidly while maintaining equity. The number of schools increased with an average of 1,712 new schools every five years between 1968 and 1992. Likewise, an average of 50,761 new teachers were recruited every five years in the same period.

Higher Education

Higher education is an extension of secondary education which consists of academic and professional education. Academic education is mainly aimed at mastering science, technology, and research, whereas professional education is aimed more at developing practical skills.

The institutions providing higher education are typically academies, polytechnics, institutes and universities.

- An *academy* conducts applied science education in one or part of a discipline, technology or the arts. A polytechnic conducts applied science education in several particular fields. Both of these forms of higher education are categorized as professional education.
- A *college* conducts academic and professional education in one particular discipline.
- An *institute* consists of faculties conducting academic and/or professional education disciplines which belong to the same group of professions held.
- A *university* consists of several faculties conducting academic and/or professional education in several disciplines, technologies and/or the arts.

In line with the efforts to strengthen national education, higher education aims to:

- (a) prepare students to enter society with academic and/or professional skills that can be applied, further developed and/or create a new science and/or technology or the arts;
- (b) develop and disseminate science, technology and the arts and apply its usage for improving the people's welfare and enrich the national culture; and
- (c) as practiced in other countries, higher education is not only managed by the government but also by the private sector.

Higher education that is provided by the government is managed by the Ministry of National Education and other ministries and agencies such as the Military Academy and the College for Civil Servants.

Each year, there is an increase in enthusiasm of high school graduates to continue studies at a higher level. Enrolment of new students into a national university is based on national entrance test and achievement monitoring process (portfolio assessment) (PMDK).

Those who are accepted through the PMDK procedure are not required to take an entrance test as they are judged to have displayed eligible academic performance ever since they were enrolled at senior high school level. However, this type of selection is not implemented at all universities. To ensure qualified graduates, the development of higher education is aimed at:

- (a) improving the quality of lecturers in academic activities and research by providing additional training;
- (b) improving the development of science and technology by increasing the number of research and development activities on the basis of present and future needs;
- (c) developing the campus as a dynamic scientific enclosure with a national orientation outlook;
- (d) developing centers of excellence for sciences as a means for students and freelance scientists to develop and improve their professional skills to participate in national development;

- (e) developing the higher education campus as a democratic environment, allowing for academic freedom, freedom of speech, and the university autonomy growing at its intellectual and professional capacity in society; and
- (f) providing facilities which conduct education, research and the development of science and technology.

Between 1968 and 1993, the participation rate in higher education increased by 5.84 per cent per year. In absolute numbers, however, enrolment in higher education multiplied more than 10-fold during the period. Among the reasons for the relatively slow growth in the participation rate, an important factor is that the vast majority of senior secondary school graduates opted for the job market and employment rather than higher education. An average of 14,540 additional teachers were recruited for higher education every five years between 1968 and 1993.

4. HIGHER EDUCATION LONG-TERM STRATEGY

4.1 *Historical perspective*

Higher education in Indonesia does not have a long history, since it was just started in the end of 19th century by establishing medical education for indigenous doctors in Jakarta. Before the Second World War, the number of students was merely around 200. After the independence in 1945, the system has been significantly expanded, particularly after the Education Act in 1961 was enacted. Currently, the system enrolled more than 3.5 million students.

In 1975, the first initiative to develop a national higher education policy was launched by developing the first Higher Education Long Term Strategy (KPPTJP) for the period 1975-1985. The national system, comprising public and private sectors, emphasized on the aspect of relevance by recognizing the need to establish strong linkages with the regional and national development. In addition to the introduction of a dual system, consisting of academic and professional streams, three programme levels in higher education were introduced, i.e., Diploma, Sarjana, and Graduate programme. The organizational and management aspects were given serious attention through the introduction of credit system, student academic evaluation, student load, and staff promotion system.

In 1986-1995, development was focused on consolidating previous achievement and improvement of quality. The economic downturn caused by the sudden drop of oil prices had prevented the student enrollment to further expand. Nevertheless, the enrollment in private sector has steadily expanded at the rate of 9 per cent per annum. An early attempt to introduce reforms in higher education by issuing a new Government Regulation (PP) 30/1990 did not achieved the expected outcome due to inadequate public and political support.

The 3rd KPPTJP 1996-2005 was developed based on the assumption that the economy will grow steadily at the rate of 6-8 per cent per annum as it was in the last ten years. In order to meet the future needs and demand three major issues are identified, namely, the need of a more dynamic management mode in higher education to cope with the dynamic changes, the need to take quality and relevance as the basic reference for higher education development, and the need for enhancing social mobility and equity through higher education development. The strategy comprises the following three core programmes: (a) implementation of the new paradigm in higher education management; improvement of relevance and quality; and (c) geographical and social equity. Based on these three core programmes, the main programme categories and main programmes are then developed.

All of a sudden, in 1997 East Asian countries, including Indonesia, experienced the worst ever economic crisis, followed by the fall of its political and social system. Between 1998 and 1999, the economy contracted by -13% and -1% respectively [World Bank, 2000]. The economic growth has only been crawling at 4% in 2002, and the previous growth of 7% enjoyed in the 1990s is not expected to revive in the next three to 5 years. The fall of the authoritarian government creates euphoria in almost every sector that the stability previously taken for granted is currently become a luxury. The centralistic approach taken by the KPPTJP III immediately becomes obsolete and cannot cope with these new types of challenges.

Meanwhile, a funding mechanism based on the new paradigm concept (the first core programme) has been implemented since 1995 and the proportion of DIP allocated under this scheme has increased to 25 per cent in 2002. All competitive funding schemes under this concept take improvement of quality and relevance (the second core programme) as its primary objective. The third core programme, expansion of enrolment to achieve geographical and social equity, however, does not meet the expectations due to financial constraints.

4.2 Vision 2010

In order to contribute to the nation's competitiveness, the national higher education has to be organizationally healthy, and the same requirement also applies to institutions. A structural adjustment in the existing system is, however, needed to meet this challenge. The structural adjustment to be carried out aims to have, by the year 2010, a healthy higher education system, effectively coordinated, demonstrated by the following features:

(a) Quality:

- education that is effectively linked to student needs, to develop their intellectual capability to become responsible citizens, and contribute to the nation's competitiveness;
- research and graduate programmes serving as the incubators responding to the needs of an adaptable, sustainable, knowledge-based economy; and integrate state-of-the-art technology to maximize accessibility to and applicability of advanced knowledge;
- system contributing to the development of a democratic, civilized, inclusive society, meets the criteria of accountability as well as responsibility to the public; and
- comprehensive financial structure nourishing participation of stakeholders (including local government), and is directly linking new investment with recurrent budget in the subsequent years.

(b) Access and equity system providing opportunities for all citizens to a seamless learning process, inspiring and enabling individuals to develop to their highest potential levels throughout life, so that he/she can grow intellectually, well equipped for work, and contributes effectively to society, as well as achieve personal fulfillment.

(c) Autonomy

- in decentralizing the authority from the central government and providing more autonomy as well as accountability to institutions; and.

• in legal infrastructure, financing structure, and management processes that encourage innovation, efficiency, and excellence.

4.3 Basic policies

The nation's competitiveness

The world is facing unprecedented challenges arising from the convergent impact of globalization, the increasing importance of knowledge as an engine of growth, and the ICT revolution. The nation's competitiveness, which is defined as a country's share of world markets for its products, comes less and less from abundant natural resources and cheap labor, and more and more from technical innovations and creative use of knowledge, or a combination of both (Porter, 2002). The ability to produce, select, adapt, commercialize, and use knowledge is critical for sustained economic growth and improved living standards. The study conducted by Solow, illustrates the empirical evidence of striking difference in GDP between countries resulting from investment in knowledge (Solow, 2001).

The nation's competitiveness can only be achieved under the framework of strong national character and civilization. In this respect, the higher education system has the responsibility in providing students with strong knowledge and understanding to be good citizens, and lead meaningful lives. The higher education system should also contribute to the process of shaping a democratic, civilized, and inclusive society, maintaining national integration through its role as moral force, and act as the bearer of public conscience.

Meanwhile at the same time, Indonesia is still in the stage of reconstruction its economy, social, and political system after experiencing the worst crisis ever. In acquiring public funds, the higher education sub-sector has to compete with more pressing sectors, i.e., basic education, poverty alleviation, and health. Although the urgency to prioritize these sectors is undeniable, neglecting and providing inadequate support to higher education would cost the nation dearly in terms of its nation's competitiveness (Solow, 2001). The strongest justification for allocating public funds to higher education is its contribution to the nation's competitiveness, critical in a knowledge-driven economy. Another important contribution is its role in supporting basic and secondary education, particularly in producing quality teachers, although in order to successfully discharge this function it requires the co-operation of agencies responsible for recruitment and deployment of its graduates. The third justification for allocating public funds is to intervene in the market mechanism, by ensuring access to higher education for academically potential but financially disadvantaged students (Salmi, 2002). Lastly, it is to protect the national interests, i.e., national integration, nation and character building, and defense.

The government, represented by the DGHE, has a responsibility to put in place an enabling framework and infrastructure to encourage institutions to be more innovative and responsive to the needs of improving the nation's competitiveness. It should also nourish and promote community and local government participation in developing institutions in a synergistic manner. It is realized, however, that the higher education system as well as the individual institution are not adequately prepared to play this role and meet such tall order.

Nevertheless, opportunities are also emerging from these challenges. The role of higher education in the construction of a knowledge economy and democratic society is stronger than ever. Its contribution to the knowledge-driven economic growth and poverty reduction is carried out through the capacity to: (a) train qualified and adaptable work force, (b) generate new knowledge to increase nation's competitiveness, and (c) access and adapt global knowledge to local use.

Autonomy

Indonesia is a highly pluralistic country and a diverse nation, reflected by its national credo: *Bhinneka Tunggal Ika* or *Unity in Diversity*. With dozens of existing ethnic groups and several hundreds of different local dialects, the country might only be comparable with Europe in terms of diversity. The diversity becomes more visible by considering the disparity in economic, social, technological infrastructure and natural resources. In such a highly pluralistic country, a universal policy that applies to every institution is not suitable. Although in urgent problems requiring quick decisions uniformity is sometimes seen as the best short-term solution; it does not fit such a heterogeneous system. Inability to centrally manage a large and complex system could also be illustrated in malpractices such as diploma mills, new types of provider (though ineligible and dubious in terms of quality), fail to be accountable in executing the requirements of the education process.

Decentralizing authority and providing more autonomy to institutions is considered as the best approach in managing such a highly complex higher education system. Bundled with decentralization and autonomy, the role of the central government, represented by the DGHE, should also shift from regulating into more empowering, enabling and facilitating. However, it could still intervene through resource allocation and other means within the context of the national higher education system. By shifting the role, responsibility and accountability will also be shifted to institutions. Providing autonomy and demanding accountability, however, needs a comprehensive and consistent policy. Each relevant aspect has to be adjusted following the policy shift such as, funding policy, personnel policy, governance, and quality assurance system.

The DGHE's role is particularly critical in preparing the coherent infrastructure to impose implementation of the new policy. For example, institutional framework and legal infrastructures are two essential aspects to be prepared, in addition to the expansion of the implementation of the new paradigm. Legal infrastructure includes Higher Education Law, necessary Government Regulations, Ministerial decrees, etc., whereas institutional framework includes adjustment of the structure and responsibility of DGHE and BHE, as well as NAB and university (including its legal status).

Organizational health

Organizational health is referred to as a state of good health or well-being in an organization. In an academic institution, such a healthy organization is characterized by its ability to flourish academic freedom, highly value innovation and creativity, empower individuals to share knowledge and work to build organization success. It should also be assembled in a healthy system. It will explicitly encourage a pro-active approach to managing change and each individual in becoming an efficient and effective organization, with clear definition of rights, responsibilities, and accountabilities. A healthy organization provides its members with the tools they need to adapt to complex and difficult situations. It gives them enough leeway and autonomy to deal with unusual demands and unforeseen circumstances. Imbedded in a healthy organization is an internally driven quality assurance mechanism, i.e., self-assessment and external evaluation.

A system comprising healthy institutions alone does not guarantee that it has the capacity to respond to the environment appropriately. Likewise, a system consisting of unhealthy institutions would not have the capacity to provide the expected response. Each institution is responsible

for the organizational health within its own institution, whilst the DGHE is responsible for the organizational health of the entire system. Although a healthy institution should also take into account various aspects in its environmental context (relevance, market trends, etc.), its focus is more toward its own organizational health. The same argument is applicable to the system-wide organizational health, where it should focus more on how the higher education system, as a subsystem, should respond to national demands.

The implementation of a market economy in a pure sense, without adequate institutional framework and legal infrastructure to protect underprivileged groups and prevent unfair competition, is never recommended, should even be avoided. A tiered competition, by grouping institutions having similar development stage, type, or focus, is more appropriate. Some institutions might not even possess the minimal capacity to conduct self-evaluation, the basic prerequisite to entry to any competition. The DGHE, therefore, has to develop policies and programmes (funding and institutional infrastructure) that would encourage institutions to improve their organizational health by providing incentives, technical assistance, and corrective measures (but should be efficient in exercising it). The improvement of organizational health would be the goal in all government programmes, and is chosen as the primary target.

Managing a higher education institution is, however, a complex operation with multibillion Rupiah turnovers. They are in receipt of large sums from public sources but many also generate significant funds from other sources. Even if the institutions are autonomous there must be a proper balance between accountability for public funds in this autonomy. Managers must attend to a vast range of requirements, from ensuring cost-effectiveness and efficiency to assuring the highest academic standards.

Unfortunately, due to the previous highly centralized system that prefers compliance to a uniform standard, such capacity in most institutions is inadequate. In order to reach the level of a healthy organization, a tremendous cultural change is needed during the transition. The DGHE has, therefore, the responsibility to develop and implement a systematic programme to improve the institutional management capacity.

5. INTERNATIONAL CO-OPERATION AND RECOGNITION

In the broad context of society and national development, education services, on the one hand, are to keep and maintain the collective knowledge and experience of the nation accumulated through centuries of history, and on the other hand, to generate the knowledge, skills and scientific progress that will maintain national development in the 21st century. Indonesian education policies are in line with the Education for All Programme which was initiated by UNESCO in 1987 and confirmed by the World Conference on Education for All in Thailand, March 1990.

As early as 1988, Indonesia established a working group known as APPEAL, the Asia and Pacific Programme on Education for All. APPEAL involves governmental departments and agencies, academic institutions and other relevant organizations. Its mandate is to coordinate efforts to provide education to all citizens.

Over the years, Indonesia has received international widespread recognition for its achievement in education for all. President Soeharto was awarded the UNESCO Avicenna award in June 1993 for his successful leadership in education development. Despite enormous progress in education, particularly in the areas of primary school enrolment and illiteracy eradication, much remains to be done.

The government has recently become committed to the virtual elimination of illiteracy by the year 2000. Meanwhile, major challenges are identified as the expansion of compulsory basic education from six to nine years, the improvement of the quality of primary and secondary education, and enhancement of the learning achievement for all levels.

Indonesia's commitment to the further development of education is based on the recognition that development goes hand-in-hand with advancement in science and technology, as Former President Soeharto has pointed out: "A nation that studies diligently is a nation that will in the future become a master of science and technology".

5.1 Types of higher education institutions

There are currently 51 state/public universities (including several teacher training institutions), 26 state/public polytechnics (engineering, commerce and agriculture) and 1,328 private higher education institutions (including academies, polytechnics and teacher training institutions). Besides, there are also Islamic higher education institutions (both private and state/public) which are under the control of the Ministry of Religious Affairs.

5.2 Co-ordination of higher education

The coordination is done by the Ministry of National Education except for the Islamic higher education institutions as described earlier. The Minister of Education and Culture then delegates the authority in these higher education matters to the Directorate General of Higher Education.

5.3 Institutional governance

At each higher education institution there is a body called a Senate which acts as a normative body to the institution. Every major decision including degree and diploma granting procedures should be approved by the Senate.

6. CHARACTERISTICS OF DEGREES AND DIPLOMAS

6.1 Types of degrees and diplomas

- A certificate is issued for short-term programmes such as courses given in continuing education or credit-earning activities.
- A diploma is granted for the diploma programmes conducted either in the polytechnics (Diploma 2 and Diploma 3) or in the academies (Diploma 2 and Diploma 3) or even the diploma programmes conducted in the universities (Diploma 3). Diploma programmes are considered to be a professional programme rather than an academic programme.
- *Sarjana* is granted for the programme conducted in the university or institute which lasts for 4 to 4.5 years after high school. This is the first academic degree in higher education.
- *Magister* is granted for the graduate programme conducted in the university or institute which lasts for nominally 2 years after *sarjana* programme (after the first academic degree).

· *Dokter* is granted for the graduate programme conducted in the university or institute which lasts for 3 to 4 years after the *magister* programme. In some cases participants can pursue doktor degree programme directly after the first degree depending upon the academic potential. *Dokter* degree is the highest academic degree granted by an Indonesian university or institute.

6.2 Title and abbreviation of degrees and diplomas

Degrees in Arts and Sciences (undergraduate degree/first degree)

No.	Study Programme	Academic degree	Abbreviation
1.	Literature	Sarjana Sastra	S.S.
2.	Law	Sarjana Hukum	S.H.
3.	Economy	Sarjana Ekonomi	S.E.
4.	Political Science	Sarjana Ilmu Politik	S.IP.
5.	Social Science	Sarjana Ilmu Sosial	S.Sos.
6.	Psychology	Sarjana Psikologi	S.Psi.
7.	Medical Science	Sarjana Kedokteran	S.Ked.
8.	Public Health	Sarjana Kesehatan Masyarakat	S.K.M.
9.	Dentistry	Sarjana Kedokteran Gigi	S.K.G.
10.	Agriculture	Sarjana Pertanian	S. P.
11.	Agriculture Technology Pertanian	Sarjana Teknologi	S.T.P.
12.	Animal Husbandry	Sarjana Peternakan	S.Pt.
13.	Fishery	Sarjana Perikanan	S.Pi.
14.	Forestry	Sarjana Kehutanan	S.Hut.
15.	Veterinary Hewan	Sarjana Kedokteran	S. K.H.
16.	Mathematics and Natural Science	Sarjana Sains	S.Si.
17.	Engineering	Sarjana Teknik	S.T.
18.	Computer and Informatics	Sarjana Komputer	S.Kom.
19.	Arts	Sarjana Seni	S.Sn.
20.	Education	Sarjana Pendidikan	S.Pd.
21.	Religious Studies	Sarjana Agama	S.Ag.

Graduate degrees in Arts and Sciences:

No.	Study programme	Academic degree	Abbreviation
1.	Literature	Magister Humaniora	M.Hum.
2.	Women's Studies	Magister Humaniora	M.Hum.
3.	Management	Magister Manajemen	M. M.
4.	Law	Magister Humaniora	M.Hum.
5.	Economy	Magister Sains	M.Si.
6.	Political and Social Sciences	Magister Sains	M.Si.
7.	Regional Studies	Magister Sains	M.Si.
8.	Environmental Science	Magister Sains	M.Si.

9.	Library Studies	Magister Sains	M.Si.
10.	National Resilience	Magister Sains Studies	M.Si.
11.	Sociology	Magister Sains	M.Si.
12.	Psychology	Magister Sains	M.Si.
13.	Mathematics and Natural Sciences	Magister Sains	M.Si.
14.	Health Studies	Magister Kesehatan	M.Kes.
15.	Public Health	Magister Kesehatan	M.Kes.
16.	Dentistry	Magister Kesehatan	M.Kes.
17.	Agriculture	Magister Pertanian	M.P.
18.	Veterinary	Magister Pertanian	M.P.
19.	Animal Science	Magister Pertanian	M.P.
20.	Development Counseling	Magister Pertanian	M.P.
21.	Agriculture Technology	Magister Pertanian	M.P.
22.	Forestry	Magister Pertanian	M.P.
23.	Fishery	Magister Pertanian	M.P.
24.	Engineering	Magister Komputer	M.P.
25.	Computer Science and Informatics	Magister Komputer	M.Kom.
26.	Arts	Magister Seni	M.Sn.
27.	Education	Magister Pendidikan	M.Pd.
28.	Religious Study	Magister Agama	M.Ag.

Professional degrees:

No.	Study programme	Professional degree
1.	Medical Sciences	Dokter
2.	Pharmacy	Apoteker
3.	Economy	Akuntan
4.	Veterinary	Dokter Hewan
5.	Dentistry	Dokter gigi
6.	Psychology	Psikolog
7.	Law	Notaris, pengacara
8.	Architecture	Arsitek

Information contained in the diploma will include: date and title conferred, field of study and the name of the institution.

7. STUDY PROGRAMMES

7.1 Number of credits

The following are the credit requirements: 144-160 semester credit units (scu's) for sarjana programme, equivalent to 4 to 4.5 years (8 to 9 semesters); 36-44 scu's for magister programme, equivalent to approximately 2 years (4 semesters). For obtaining a dokter degree, there is no scu requirement since it is mostly research-based and independent study. However, there is a residential requirement for 2 years and the candidate should pass the examinations conducted every year (to check the progress in research).

7.2 Practical experience

It is mandatory for a student to take this before he/she graduates. The practice could last from 4 to 6 months depending on the programme and capability of the concerned parties. Usually students take this practice in his/her final year. The component of this practice could be in the form of field study, industrial training, etc.

7.3 Grading and evaluation

The grading system uses letters A, B, C, D and E (fail), in which A is considered to be 4, B is 3, C is 2 and D is 1. Numbering is for the purpose of calculating grade point average (GPA). To graduate from all institutions in higher education, participants should maintain a minimum cumulative GPA of 2.00.

8. ADMISSION REQUIREMENTS

Admission to the sarjana programme in the state/public universities is done through the national entrance examination or through direct selection by the university (or talent scouting). Admission to other programmes is done directly by the university.

9. ASSESSMENT OF HIGHER EDUCATION INSTITUTIONS

The body which is responsible for the assessment and accreditation of the programme is the National Accreditation Board (BAN). The accreditation process is conducted by doing desk evaluation and also by site visits; both private and public institutions would be treated equally. The BAN is an independent body which reports to the Director General of Higher Education.

10. DEGREES AND PROFESSIONAL COMPETENCIES

The license for practice will be issued by the professional association or by a joint team between universities with professional associations. The sarjana graduate could not immediately practice in industry but he/she has to follow several in-house training programmes, or he/she follows a formal professional programme or specialist programme. Some associations require some experience from the candidate before the license is issued.

11. INTERNATIONAL RECOGNITION OF DEGREES

Indonesia has not yet signed the UNESCO Regional Convention on the Recognition of Studies. Efforts in setting up recognition of degrees are being made through co-operation with higher education institutions overseas enhanced by such programmes as twinning/double degree agreements.

SOME STATISTICAL DATA IN 2000, 2001, AND 2002

- Number of state or public universities: 76 (2000), 80 (2001), 81 (2002).
- Number of private universities: 1,749 (2000), 1,931 (2001), 2,169(2002).
- Number of students enrolled at state or public universities: 795,000 (2000), 845,110 (2001), 851,934 (2002).

- Number of students enrolled at private universities: 1,992,320 (2000); 2,114,060 (2001); 2,223,780 (2002).
- Number of faculty members at state or public universities: 53,207 (2000); 55,296 (2001); 56,955 (2002).
- Participation rate in higher education: 12.4% (2000); 13.0% (2001); 13.6% (2002).
Percentage of budget in higher education institutions (state or public institutions): 48% recurrent budget provided by the government, 37% development budget provided by the government and 15% of the budget obtained from tuition fees, etc. This figure is for the 2003 fiscal year

ISLAMIC REPUBLIC OF IRAN

Abdolmajid Eskandari

1. COUNTRY PROFILE

The term Persia evokes at once the image of a land of a long ago and that of a present reality in the heart of Asia. Known to the west as Persia until 1935, Iran was settled by a group of closely related Aryan tribes as early as the 9th century B.C. The Medes who first established an empire, were superseded in 550 B.C. by the Persians who eventually attributed the name of Iran to the country. Since then, in the course of history of Iran many monarchs had come and gone. With the culmination of the Islamic Revolution, Iran became officially the Islamic Republic of Iran in 1979.

Iran with an area of 1,648,000 square kilometres, is a vast region in Southwest Asia. Its neighbours consist of Turkey and Iraq in the West, Turkmenistan, Azerbaijan-Naxicvan and Armenia in the North, Afghanistan and Pakistan in the East. Iran also has a total of 2,500 kilometres of sea frontier including the Persian Gulf, the Oman Sea in the South and The Caspian Sea in the North.

Out of the total area of Iran, about 20.7 per cent is desert and unarable land, 54.9 per cent natural pastures, 7.6 per cent forest land and the remaining 14.4 per cent is potentially arable land. The northern shores of Iran, along the Caspian Sea are lush green lands, covered with forests. The southern shores of Iran stretch over 1,800 kilometres along the Persian Gulf and the Oman Sea. The mountainous regions, serve as suitable places for animal husbandry and migratory groups. The central plateau of Iran has a limited agricultural activity on account of its climatic conditions but it is extremely rich in its underground resources. The well-known deserts of Iran have a very wide expanse.

Iran has a variety of climates. The population of Iran is about 68.9 million. More than half of the country's population is the active group within the age levels of 15-64 while about 46 per cent of the total population are under 14 years of age.

As Iran is situated on the direct route of Central Asia, Turkey and Arab countries, a variety of racial groups are found to be living there (Persian, Azeri, Gilaki, Mazaandarian, Kurd, Arab, Lur, Balooch, Turkmen and others). The official and common language and script of Iranians is Farsi (Persian). The beginning point of the calendar year is the year of the emigration of the holy prophet of Islam from Mecca to Medina. The twenty-first of March is adopted as the first day of the New Year (No-Ruz). The official calendar basis of the country is the Hejira Solar year. The official religion in accordance with article 12 of the Islamic Constitution is Jafari faith of the twelve Imams. About 98.5 per cent of the population are Muslims, most of whom belong to the Shi'a sect. Other religious Islamic sects are Hanafi, Shafe'i, Maleki, Hanbali and Zeidi, all of which are respected and enjoy full freedom. The rights of Zoroastrian, Christians and Jewish groups have been formally recognized.

The government of Iran is the Islamic Republic of Iran which the nation affirmed in the National Referendum held on April 1st 1979, with a majority of 98.2 per cent. The main exports of Iran include oil, natural gas, copper, mineral stones, carpets, caviar, agricultural products, etc.

2. NATIONAL EDUCATION SYSTEM

A glimpse at the history of higher education in Iran reveals the significance of education among Iranians. On its several thousand years history from ancient times to the Ackamanid era and from then up to the present time, Iran has been the cradle of science and scientists. Incessant efforts have been made in this connection. An example is the existence of schools like Jondishapour, which after a while had Beitolhakameh as its follower and in a short time proved to be the pioneer of different branches of science. Despite the ancient history of higher education in Iran, the establishment of modern higher education centres dates back to the 19th century when Amir Kabir founded the Darolfonoon polytechnic school and awarded scholarships to students to go overseas to pursue their studies in order to upgrade higher education in Iran in all spheres.

Education

The education system of I.R. of Iran consists of one year Pre-School (Kindergarten), five years Primary School, three years Guidance School, three years Secondary School and one year Pre-University programme. The Ministry of Education is responsible for Pre-Higher Education programmes.

Pre-School education is a one-year period in which 5-year old children are prepared for the primary school. In bilingual areas where Persian is not their mother tongue, they will be taught the Persian language. The Primary School for children in the age group 6-11 is the first stage of formal education. The Guidance School takes three years of children from 12-14 years old.

Secondary Education

It comprises three years schooling for children of the age group 15-17. It offers three branches namely:

- Theoretical
- Technical-Vocational
- Skill-Knowledge (Kar-Danesh)

Each are divided into different fields. The courses are offered in the form of the unit credit system. The required total number of credits leading to Secondary School Diploma is 96. The offered courses in the first year are common and after successfully completing the first year, based on aptitude, interest and the grades in guidance school and the first year programme are directed to the concerned branches and can continue their studies.

Note: In the first common year, if a student fails in passing a unit credit, he/she is considered failed and has to repeat the whole unit credits (one-year programme) and then take part in the examination. If he/she fails in two consecutive years, he/she is not permitted to continue studies in regular classes and is obliged to study in evening classes.

Note: In the Second and Third year of Secondary Education, if a student fails to pass a unit credit, he/she can pass it in summer and it will not disturb his/her continuing his studies.

One-Year Pre-University Programme (32 Units)

This course prepares students to enter universities and higher education centres. To enter this course, the students should pass the concerned examination. After successfully passing the one-year period (two semesters, each term of approximately 4 months), the students are granted the Pre-University Certificates and are permitted to take part in the Nationwide Entrance Examination of universities and higher education centres.

Note: The qualified students entering Technical-Vocational and Skill-Knowledge branches can continue their studies either leading to Post-Diploma Degree-Technical, (170 unit credits) or take part in the Pre-University Examination.

Note: Those who wish to acquire skills before completing the secondary education period, can enter the Skill-Knowledge Branch and receive First (48 unit credits) or Second (32 unit credits) Class Skill Certificate or can take part in the Pre-University Examination as well.

Note. All students can take part in Pre-University Examination. Those with high GPA can take part in regular classes and those with low GPA will take part in evening classes.

Non-Profit Schools (Private)

According to the law passed by the Islamic Parliament in May 1988, bona fide persons can establish Non-Profit Schools. The educational curriculum, textbooks and degrees and the rate of tuition fees are governed by the general regulation of the Ministry of Education. The tuition fee is paid by the students upon registration.

Non-Formal Education (Sub-Division of Formal Education)

Literary Movement Organization (LMO)

It began its activities after the victory of Islamic Revolution in 1979 and educates illiterates in three stages namely: Elementary, Supplementary and Final leading to degrees acceptable for the continuation of studies.

Adult Education

This provides education for those who have not been able to finish their studies in proper periods. It is represented in the 5th year of elementary level evening classes and secondary education. It is implemented in semesters and the youngest age of the learner is 18. The subjects, except for physical education are the same as in formal education.

Technical and Vocational Centres

They are conducted by the Technical and Vocational Training Organization of the Ministry of Labour and Social Affairs and also by some other ministries. The graduates are granted different certificates of skills based on global standards.

Teacher training affairs have been centralized in one unit called the Teacher Training Bureau affiliated to the Ministry of Education.

Rural Teacher Training Centres

These centres select the students among the native graduates of guidance schools and they offer two kinds of programmes: 4-year and 2-year programmes. The native graduates are selected to be trained in their own areas.

International Schools

There are International Schools for foreign students which perform the programmes of International Association of Schools and follow the world standards.

Special schools for the Exceptional (Retarded) children are also offered by the Ministry of Education. The gifted students have also their own specific schools. Education for minority groups, migrant tribes (Ashayer), etc., are also offered by the Ministry of Education.

3. HIGHER EDUCATION SYSTEM

3.1 Types of higher education institutions

Encompassing the universities, institutes, colleges and higher educational centres, they are in the form of public, non-profit, open and comprise the following categories:

- Comprehensive universities in which all educational fields are offered.
- Specialized universities in which only one of the educational fields is offered.
- Comprehensive universities of Technology offering all technological education.
- Medical Science universities offering the medical and allied medical education.
- Comprehensive University of Applied Sciences.

A. Public Sector

Educated manpower and specialists are supplied by the Ministry of Science, Research and Technology (MSRT) in Iran. However, other ministries and public institutes are also involved in training specialists. Since medical education was delegated to the Ministry of Health, Treatment and Medical Education (MHTME) in July 1985, all duties and responsibilities of the MSRT in the area of medical education were transferred to the new ministry for the purpose of efficient use of facilities and hospitals.

Presently, a great number of universities and institutes of higher education are active under the Ministry of Science, Research and Technology and Ministry of Health, Treatment and Medical Education. There are other higher education institutes that are affiliated with other ministries. They specifically provide pre- service and in-service courses for their current and prospective employees. Finally, students pay no tuition fee to public universities.

Note: The list of academies of sciences, universities and higher education research institutions (Public and Private Sectors) of the I.R. of Iran are presented in Annex 1 of this report.

Distance Education

Payame Noor University (PUN)- Public Sector

This university was established in 1988. This university primarily aimed at providing distance (corresponding) education around the country. Teaching is mainly through correspondence courses and by the use of audio-visual materials. Self-instruction materials are frequently used but the students also have a possibility of attending classes. It allocates some of the broadcasting time of IRIB network to broadcast its educational programmes. There is no age limit for the students. The programmes of the university are based on the integration of education and information technology.

Higher Education Evening Programmes

Higher Education evening programmes follow the same rules as the regular public educational centres and only the tuition is paid by the students. The duration of study for associate and bachelor's degrees is four and eight years, respectively.

University Teacher Training Programmes

Due to the need of the country for qualified high school teachers, these centres have been established. Students who wish to study in these universities should mention their interest in the Nationwide Entrance Examination and apply for scholarship.

Instructor Training University

Tarbiat Modares University (TMU) (Public Sector)

Tarbiat Modares University (TMU) was founded in 1982 after the Islamic Revolution of Iran. The main goal of this university is training academic staff of universities as well as researchers required for universities and higher education centres. This university focuses exclusively on graduate studies, primarily aiming at meeting the increased demand of universities for qualified faculty members.

Comprehensive University of Applied Sciences (Public Sector)

It was established on October 10, 1993. It aims at providing grounds for co-operation between organizations and institutions in both the government and private sectors in terms of human resource development. Programmes offered aimed to help employed people to increase their skills in order to perform their jobs better in various organizations. It also strives to promote scientific applied education and to equip the graduates with necessary knowledge and skills. Moreover, the Comprehensive University of Applied Sciences is also active in improving vocational training and supplying skilled manpower for industry, agriculture and service sectors.

Among other universities and institutions of higher education centres founded after the Islamic Revolution are Imam Sadeq (AS) University, Shahed University and Shahid Motahary Higher Education School.

In-Service Training

In order to update the teachers' knowledge and skills and to train administrative personnel, the Ministry of Education and other ministries offer special short term and long term courses which lead to higher education degrees.

Teacher Training Centres

These post secondary institutes select their students from high school graduates by entrance examination. There are two types of teacher training centres i.e., General and Technical-Vocational. In the General type, the students are boarded during their two-year studies and are awarded Associate Degree and can teach in primary or guidance schools. In the Technical-Vocational type, the students are selected from the graduates of secondary technical and vocational school and they are active in training technicians for the secondary technical and vocational schools.

Imam Khomeini International University

As the first international university in Iran, it was founded in 1984 with the mission of disseminating Islamic knowledge and offers different educational programmes for foreigners as well as Iranians. The main campus of the university is located in Qazvin.

The language of instruction in all higher education centres of Iran is Persian (Farsi) and there are special classes for teaching Persian to the foreign students.

B. Private Sector

Qualified bona fide persons, having academic qualifications and sufficient financial abilities can establish universities or other educational and research institutions by obtaining the required patent from the Ministry of Science, Research and Technology. Private universities and institutes were established in order to increase public contribution to higher education, to relieve the government's financial burden, and to meet the ever-increasing social demand for higher education.

Islamic Azad University (Non-Profit Private)

Due to the increasing social demand for higher education, the Islamic Azad University was established in 1982. The main objective of the university has been directed towards mobilizing all potentials of the country for the expansion of higher education. With branches in most cities of the country, this university is the first non-governmental university established since the Islamic Revolution. The Islamic Azad University, with the exception of tuition fees which requires the students to pay upon registration, follows the educational regulations of public institutions. Students are selected through nationwide university entrance examinations for medical, non-medical and part-time courses.

Note: All universities and higher education centres of Islamic Republic of Iran are open to both males and females. There is also one university (Azzahra University) which gives admission exclusively to women students.

3.2 Coordination of higher education

Supreme Council On Higher Education Planning

After the victory of the Islamic Revolution, for the purpose of training specialized manpower according to the economic development plan and to make use of the full capacities of the universities, a centralized planning for higher education was adopted. The task is undertaken by the Supreme Council on Higher Education Planning (SCHEP) and the Minister of Science, Research and Technology (MSRT) acting as its chairman. The SCHEP was approved by the Supreme Council of Cultural Revolution (SCCR) on its 10th session February 17, 1984. The main functions of SCHEP are as follows:

- to design the future trends of higher education in Iran;
- to supervise the new programmes, curricula and courses; and
- to draw up the rules, regulations for the different levels of higher education.

Due its function, the SCHEP is composed of the following divisions/offices: Council of Chairmen, eight Specialized Planning Groups, Rules and Regulations Committee and Secretariat.

3.3 Institutional governance

Different institutions in the universities, based on the general educational policies made by SCCR and SCHEP undertake part of the responsibility of governing the higher education centres.

Board of Trustees

Universities and institutions of higher education and research are supervised by Boards of Trustees which include:

- the Minister for MSRT (Non-Medical Universities) or MTHM (Medical Universities),
- the President of the University,
- 4-6 Academic, Cultural, Social and Local Figures,
- the Head of Planning and Budgeting Organization or his/her representative.

The Board draws the general regulations, budget affairs, funds, evaluates and determines the methods of teaching, etc.

University Council

The University council in each university supervises and draws the concerned educational programmes and assists the president.

Board of Promotion

It approves the academic competency of the teaching staff for promotion of ranks and employment regulations as well.

The Central Administration Board

The President of the University and the Vice-Presidents in each university supervise and coordinate the implementation of educational and administrative regulations.

4. CHARACTERISTICS OF DEGREES AND DIPLOMAS

4.1 Types of degrees and diplomas

Higher education in Iran encompasses four levels: Associate degree (Post Diploma), Undergraduate leading to B.A. or B.S. degree, Graduate leading to M.S. or M.A. and Ph.D. In Medical Sciences (Continuous programme), the professional doctorate degree and postgraduate medical certificate/diploma, as well as advanced post graduate diploma are granted.

Education Field

The higher education system of Iran encompasses the following fields:

- (1) Human Sciences
- (2) Basic Sciences
- (3) Veterinary and Agriculture Education
- (4) Teacher Training Co-ordination
- (5) Technical and Engineering Education
- (6) Medical Education
- (7) Art
- (8) Technological Education (Scientific-Applied)

The specialized groups of SCHEP also operate based on the above-mentioned classification.

Credits

Higher education throughout the country is based on the unit system, i.e., credits are awarded on the semester-hour basis. A total of at least 17 hours classroom work, or 34 hours laboratory work or 51 hours practical (workshop) is required for the students to gain one credit.

(Continuous or Split) programmes

The Bachelor's and Master's programmes are performed in two types: Continuous and Split. In the Bachelor's Continuous type, the students are selected among the graduates of secondary education (old system) or Pre-university programme (reformed system) and in Split type they are selected among the graduates of associate programmes.

In masters' programmes (Continuous type) the students are selected among the graduates of secondary education (old system) or Pre-university Programmes while for split type the students are selected among the graduates of bachelor's programmes.

4.2 Title and abbreviation of the degrees and diplomas

The following degrees and diplomas are awarded upon completion of specific requirements:

- Associate in Arts (A.A.)
- Associate degree in Sciences, Engineering, Medical Sciences, Agriculture (A.S. [A.D.])
- Bachelor of Arts (B.A.)
- Bachelor of Science (B.S.)
- Bachelor of Laws (L.L.B.)
- Master of Arts (M.A.)
- Master of Science (M.S.)
- Master of Laws/Criminal and Criminology (L.L.M.)
- Doctor of Philosophy (Ph.D.)
- Doctorate Professional Degree in Medicine (M.D.)
- Doctorate Professional Degree in Pharmacy (Pharm.D.)
- Doctorate Professional Degree in Dentistry (D.D.S.)
- Doctor of Dental Surgery
- Doctorate Professional Degree in Veterinary Medicine (D.V.M.)
- Fellowship Certification/Residency Certification/Board Subspecialty Certification (Medicine)
- Post Graduate Medical Certificate/Diploma

Advanced postgraduate Medical Diploma

Note: The A.A./B.A. degrees are granted to the graduates of arts, human sciences and A.S.(A.D.)/B.S./M.S./ degrees are conferred to the graduates of basic sciences, agriculture, engineering, medical sciences (except the professional doctorate degree in medicine, dentistry, pharmacy, veterinary medicine) and Ph.D. is granted in all above-mentioned educational fields.

Note: L.L.B. in Judicial branch and L.L.M. in criminal law, criminology and civil law are awarded to the concerned graduates, respectively. Holders of Postgraduate Medical Certificate or Diploma use the title of their specialization such as Neurologist, Ophthalmologist, etc.

4.3 Information contained in the document

The following are contained in the document: personal data of the recipient, date of graduation, level of the degree, name of the field of study, name of the institution, signature of the dean of the faculty and the president of the university, and in advanced postgraduate degree in medical science the signature of the concerned minister.

5. STUDY PROGRAMMES

Each academic year includes two semesters, 16 weeks each. The first semester begins in September and ends in January and the second semester begins in February and ends in July. Each summer programme includes 6 weeks of education. There is a summer recess from July 15 to September 10. Examinations are held at the end of each semester. Courses in undergraduate programmes are divided into the following categories: general, basic, major and specialized. General courses are designed to develop general knowledge, whereas basic courses are intended

to provide an academic base for major and specialized courses. Major courses are the basis of specialized courses, which in turn enhance the theoretical and practical ability of students. Academic courses are mainly compulsory, with a few elective ones relevant to the field of study. Teaching is done through lectures, seminars, as well as laboratory classes and fieldwork.

5.1 Number of credits and sequence of study

Depending on the major of the course, the number of credit units for obtaining the **Associate degree** is 68-72. (It usually takes two years to complete) and 65-70 for split **Bachelor's degree** (two years, i.e., four semesters). It is 130-135 units for the Continuous undergraduate programme leading to a bachelor's degree (four years, i.e., eight semesters). In Technical Engineering programmes leading to a bachelor's degree the maximum units are 130-140. For a **Master's degree** (Split), it is 28-32 unit (two years, i.e., four semesters) including the submission of a thesis (4-10 units).

Note: Through passing the educational stage of doctorate programmes, the university instructors can promote their scientific capabilities and find opportunity to get a higher rank.

The **Ph.D. programme** which is the highest education level in Iran is performed in two stages: Academic and Research. The students start research after passing 16 to 30 credits as well as the comprehensive examination. They will obtain the Ph.D. by writing their dissertation and defending it before the dissertation committee (Board of Jury). The course duration is 4.5 years (42-50 unit credits). In exceptional cases, upon the suggestion of an adviser and confirmation of the faculty, 3 semesters can be added to the permitted duration of studies.

Professional Doctorate Degree in Medicine, Dentistry, Pharmacy, or Veterinary Medicine

Medicine comprises General Courses in 4 stages namely:

- First stage: Basic Sciences (5 semesters, 91 theoretical and practical credit units) if the students pass the comprehensive examination they can attend the next stage
- Second stage: Symptomatology and physiopatology (2 semesters, 30 practical and theoretical units)
- Third stage: Externship (95 units) during the 9 months in this stage they attend hospitals and if they pass the pre-internship examination successfully, they can continue their study and attend the next stage
- Fourth Stage: Internship (68 credits units) 18 months. The last stage requires the submission of a thesis (6 units) and a total of 290 units for obtaining the professional Doctorate degree in medicine. In this stage the students can practice medicine. Then the students can take part in the "examination of residency programme" (3-5 years) in different fields such as ENT, Dermatology, Cardiology, Pediatrics, etc.

At the end of the programme, if they pass the Pre-board examination, they will be awarded the Pre-board certification and can practice medicine only but if they pass both Pre-board and Board examination, they can be employed as a member of the academic staff and upon confirmation and agreement of their concerned university, can begin their advanced programmes (1-3 years), fellowship (1 year) and if they succeed can obtain an advanced postgraduate medical diploma.

Professional Doctorate Degree in Dentistry

The duration is 6 years or 11 semesters; 2 years for basic sciences. After successfully passing the comprehensive examination, they can continue their specific courses which lasts for 3 years and at the end, by submitting a thesis they are awarded Doctor of Dental Surgery degree and can practice dentistry.

There are postgraduate specialized programmes that are based on interest which they can continue such as Oral Pathology, Orthodontics, Endodontics, Oral Medicine and Diagnosis, Fixed Prosthodontics, Removable Prosthodontics, Periodontics, Oral and Maxillofacial Surgery, Pedodontics, Operative Dentistry, and Dental Material, Oral and Maxillofacial Radiology, etc., and if they pass the Board Examination, they are considered specialists in that concerned field.

Professional Doctorate Degree in Pharmacy

The total units are 203 including the basic sciences with 88 credit units and specialization programmes comprising 114 credit units including practical supervised training in pharmacy or pharmaceutical factories. At the end, by submitting a thesis, they are awarded the professional doctorate degree in pharmacy, can practice pharmacy and if their total GPA is above 15, can take a specialized programme in different fields such as pharmacology, pharmaceutics, pharmacognosy, etc., in the form of Ph.D. programmes which include two years theoretical and educational courses, a comprehensive examination and two-and-a-half years practical courses and a thesis as well (total of six years).

Professional Doctorate Degree in Veterinary Medicine

The total period is 6 academic years, 227 units and includes two summer periods of full-time field training between the 4th, 5th and 6th years while maintaining a satisfactory level of performance in all course work. Degree candidates must submit a thesis as well. (The course work is divided into four phases: General Courses, Basic Veterinary Sciences, Pre-veterinary and Clinical Sciences and Internship). At the end, they are awarded D.V.M. Holders of a D.V.M. degree may apply for admission to residency programmes in different fields such as Veterinary Anatomy, etc.

Note: In case of utilizing the advantages of free education, all graduates should offer educational services in different parts of the country to fulfill their commitment.

5.2 Practical experience

Prior practical experience for some departments such as sculpture and music is an advantage in the practical competition for entering the university. In some other educational fields such as medicine, pharmacy, veterinary medicine and dentistry, agriculture, teacher training centres, practical experiences are undertaken as an essential part of the educational curricula and is compulsory. In some foreign languages in which the students have no experience, the universities provide special pre-requisite classes.

5.3 Grading and evaluation

Grades are given to each student on the basis of a 20-point grading system with the following considerations. The minimum acceptable grade in each course are:

- Grades less than 10: unacceptable for Associate/Bachelor's degree programmes
- Grades less than 12: unacceptable for Master's degree programmes
- Grades less than 15: unacceptable for Ph.D. programmes
- The total GPA for Associate / Bachelor degree no less than 12
- The total GPA for Master's degree is no less than 14
- The total GPA for Ph.D. degree no less than 15

In the professional doctorate programme in medicine, the lowest grade for basic sciences, symptomatology, physiopathology is 10 and for each of the theoretical courses of Externship and Internship, it is 12. The GPA in each semester of the first and second stages should not be less than 12, and if not, he/she will be enrolled conditionally. The total GPA in the second stage must not be less than 12 and in the third and fourth stages not less than 14.

The standard for evaluating educational achievement is the grade of students in every course and is determined numerically between 0-20 and also depends on the rate of class attendance, activities, assignments and the results of the mid-term examination. The professor of that class is considered the best evaluator of the student.

6. ADMISSION REQUIREMENTS

All applicants for higher education institutions including Associate, Bachelor's degree programmes and Master's degree programmes (Continuous), Professional Medical Science Doctorate Programmes should pass the Nationwide Entrance Examination held by the Ministry of Science, Research and Technology annually. The different fields of study in the Nationwide Entrance Examination have been divided into 4 main groups: namely, Mathematics and Technical Sciences, Experimental Science, Human Sciences and Art.

The Ph.D. programmes have a specific entrance examination which are held by each university individually. They also follow the general approved rules made by SCHEP. For Master's degree programmes (split), the applicants also should take part in the centralized examination held annually by the Ministry of Science, Research and Technology.

Having a secondary education diploma or Pre-university Certificate is acceptable for higher education, and passing the Nationwide Entrance Examination and making pledges for offering service or paying the tuition fees are essential requirements for entering universities in Associate, Bachelor's and Master's (Continuous) degree programmes.

In Ph.D. programmes, the applicants should hold an M.A./M.S. degree or Professional Doctorate Degree, pass the entrance examination, as well as the interview, and present at least two recommendations from two former professors and should pass a foreign language examination.

There is no age limit for studying in Ph.D. programmes. Those who wish to obtain a scholarship may face an age limit, for instance not more than 33 years of age.

For **International Students**, information on admission of Foreign Students are presented in the website of each individual university and respective ministries as well.

7. DEGREE CONFERRING AGENCIES

Each institution which formally follows the approved regulations of SCHEP is authorized to confer degrees and in any case the original degree will be submitted to the graduates by the official confirmation made by the concerned ministries.

8. ASSESSMENT OF HIGHER EDUCATION INSTITUTIONS

The Ministry of Science, Research and Technology based on the criteria approved by the Higher Council of the Cultural Revolution and SCHEP issues the approval for establishing any kind of educational institution and monitors and supervises their affairs.

In other words, the Ministry of Science, Research and Technology and the Ministry of Health, Treatment and Medical Education undertake the responsibility of the proper implementation of approved rules.

9. DEGREES AND PROFESSIONAL COMPETENCE

To practice Medicine, Dentistry, Pharmacy, or Veterinary Medicine one should satisfy his/her commitments including military services (males), offering services in different deprived areas in the country and then he/she can request a license from the concerned Ministry.

Teachers can be selected either among the graduates of Teacher Training Centres or free applicants through examination and interview. Graduates of law can have notary public office, provided that they pass the examination held annually by the General Organization of Documents and Estates of Iran or practice law and become a general attorney at law.

10. INTERNATIONAL RECOGNITION OF DEGREES

Iranian degrees are generally accepted and recognized internationally. The graduates of Iranian Universities are accepted directly into the leading universities throughout the world. Generally speaking, each year the Ministry of Education, Ministry of Science, Research and Technology and Ministry of Health, Treatment, and Medical Education sign cultural memorandums with higher education centres in different countries in which an article is devoted to the mutual freedom to evaluate and recognize each other's degrees.

The General Office for Foreign Graduates Affairs, affiliated to the Ministry of Science, Research and Technology and the Ministry of Health, Treatment and Medical Education, based on the standard rules made by the Evaluation Council (which comprises educational staff and experts), evaluates the level of degrees granted by different universities and higher education centres throughout the world. In the process of evaluation the degrees granted by foreign universities, type and reputation of the university, admission requirements, duration of studies, number of units, scores, quality of thesis, number of scientific papers which have been published in connection with these are considered as important criteria.

REFERENCES

- A Guide to Students Educational Information, Academic Year, 2002-2003*, Office of the Vice-President for Academic Affairs, University of Tehran, 2002.
- A Guide to Nationwide Entrance Examination*, Islamic Azad University, Farhang Afrinsh, 2001-2.
- A Glance at Higher Education in the Islamic Republic of Iran*, (Office of the Deputy Minister for Students and Cultural Affairs), Ministry of Science , Research and Technology, 2003.
- Bulletin of Tehran University of Medical Sciences*, 2003.
- General Rules of New System of Secondary Education*, Ministry of Education, Fifth Edition, 2003.
- Higher Education in Iran, A National Report 2000*, Ministry of Science , Research and Technology, August 2001.
- Higher Education Statistics at a Glance*. Institute for Research and Planning in Higher Education, Ministry of Culture and Higher Education, September 1994.
- Islamic Republic Of Iran Today*, 1st Edition (published by the Islamic Propagation Organization), 1987.
- The Development of Education*, National Report of Islamic Republic of Iran by the Ministry of Education and Ministry of Culture and Higher Education, 1994.
- University of Tehran Bulletin**, The University of Tehran Press, 2002-3.

Diagram 1

Structural Chart of the Educational System (Reformed System)

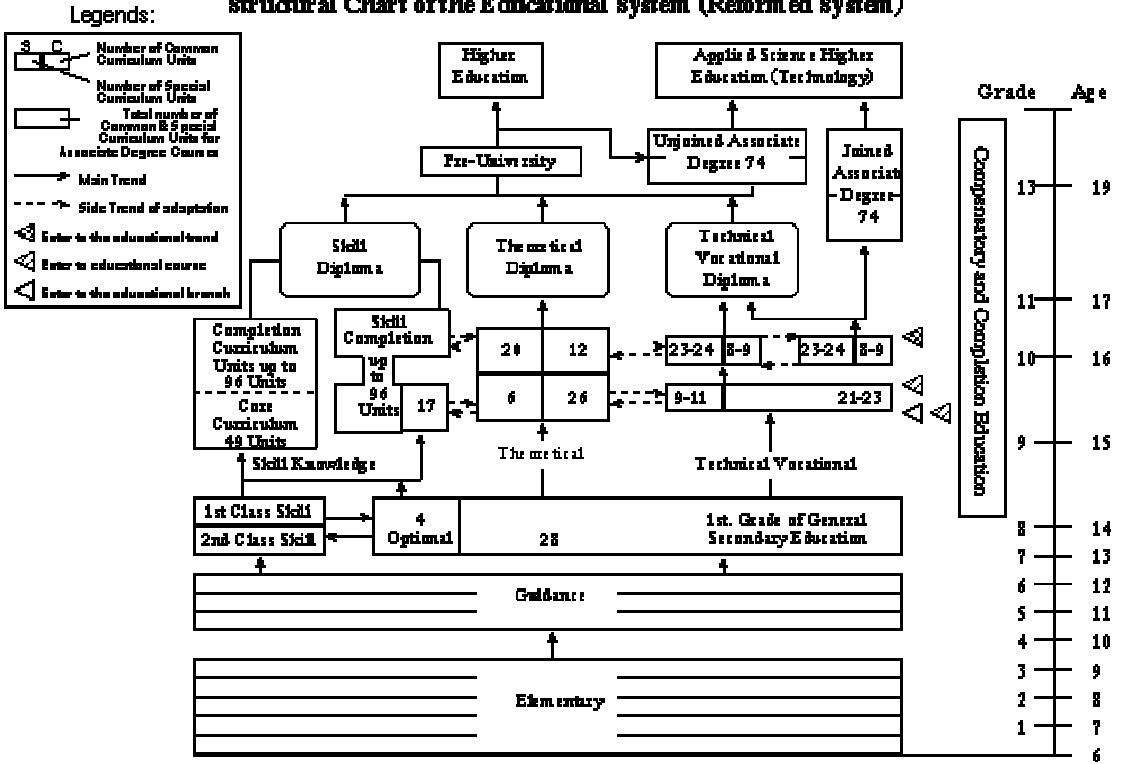
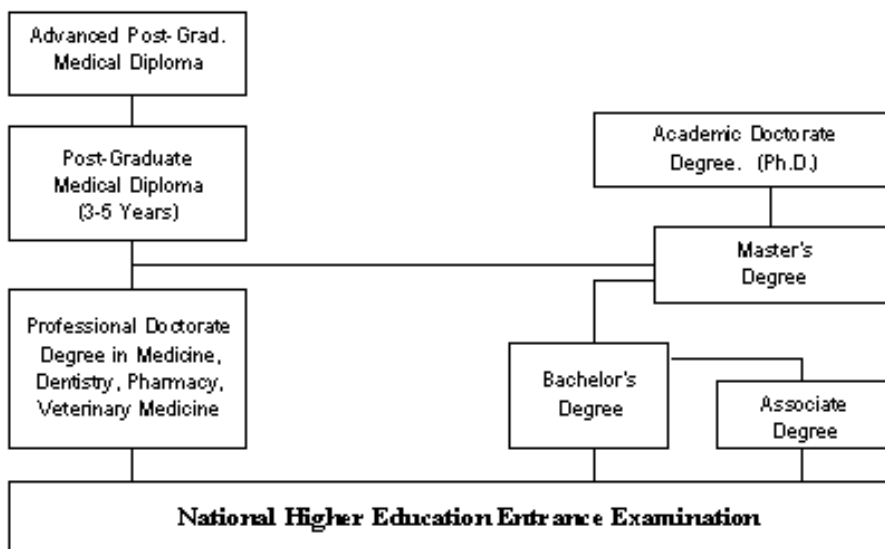

Diagram 2
Chart of Higher Education System



Annex 1**List of Academies of Sciences in the Islamic Republic of Iran**

The Academy of Persian Language and Literature of Iran
 The Academy of Medical Sciences of the Islamic Republic of Iran
 The Academy of Sciences of the Islamic Republic of Iran
 The Academy of Art of the Islamic Republic of Iran

List of Universities and Institutes of Higher Education affiliated with The Ministry of Science, Research and Technology

Arak University
 The University of Eilam
 Azzahra University (Exclusively for Girls)
 University of Isfahan
 University of Orumiyeh
 University of Birjand
 Bou Ali Sina University
 Payame Noor University
 University of Tabriz
 Imam Khomeini International University
 Tarbiat Modarres University
 Teacher Training University of Tabriz(Tabriz University of Tarbiat-e Mo' alem)
 Teacher Training University of Tehran
 Teacher Training University of Sabzevar
 Persian Gulf University
 University of Tehran
 Comprehensive University of Applied Sciences
 University of Zanjan
 Razi University
 Sahand University of Technology, Tabriz
 University of Semnan
 University of Sistan and Baluchestan
 University of Zabol
 Shahed University
 University of Shahrood
 University of Shahrekord
 Shiraz University
 Shahid Chamran University of Ahvaz
 Shahid Beheshti University
 Shahid Bahonar University of Kerman
 Sharif University of Technology
 Sahand University of Technology, Tabriz
 Isfahan University of Technology
 Khadjeh Nassir-Al-Deen Toosi University of Technology
 Amir Kabir University of Technology
 Iran University of Science and Technology
 Domghan College of Basic Science
 Allameh Tabatabai University
 Gorgan University of Agriculture and Natural Resources
 Kashan University

Ferdowsi University of Mashad
The University of Qom
Gilan University
Kurdistan University
The University of Mazandaran
The University of Mohaghegh Ardebili
The University of Lorestan
Centre for Graduate Studies in Pure Sciences , Zanjan
The University of Vali-Asr , Rafsanjan
The University of Art
The University of Hormozgan
Yazd University
The University of Yasooj

List of Universities and Institutes of Higher Education affiliated to the Ministry of Health , Treatment and Medical Education

Arak University of Medical Science
Ardabil University of Medical Science
Ahvaz University of Medical Science
Orumiyeh University of Medical Science
Isfahan University of Medical Science
Eilam University of Medical Science
Iran University of Medical Science
Babol University of Medical Science
Bousher University of Medical Science
West Azarbaijan Province University of Medical Science
Birjand University of Medical Science
Tehran University of Medical Science
Jahrom University of Medical Science
Rafsanjan University of Medical Science
Sabzevar University of Medical Science
Zahedan University of Medical Science
Zanjan University of Medical Science
Shahrood University of Medical Science
Semnan University of Medical Sciences
Shahid Sadooghi , Yazd University of Medical Science
Shahid Beheshti University of Medical Science
Shahrekord University of Medical Science
Fars Province University of Medical Science
Fasa University of Medical Science
Qazvin University of Medical Science
Qom University of Medical Science
Kerman University of Medical Science
Kashan University of Medical Science
Kurdistan University of Medical Science
Golestan University of Medical Science
Kermanshah University of Medical Science
Gilan University of Medical Science
Lorestan University of Medical Science

Gonabad University of Medical Science
 Mazandaran University of Medical Science
 Mashad University of Medical Science
 Hormozgan University of Medical Science
 Hamedan University of Medical Science

List of Universities and Institutions affiliated to other Ministries and Government Organizations

Imam Hossein (AS) University
 Imam Ali (AS) University
 Faculty of Economic Affairs
 Shahid Rajaei Teacher Training University
 University of Industries and Mines
 University of Oil Industry
 Shahid Sattari School of Aviation
 Malek Ashtar University of Technology
 The University Law Enforcement Science
 Imam Khomeini Marine Science University, Noshahr
 Cultural Heritage Higher Education Centre
 The School of International Relations
 IRIB Faculty
 Faculty of Judicial and Administrative Services, Ministry of Justice
 Shahid Abbaspour School of Power and Water Industry
 Shahid Motahari Higher School

List of Private Universities and Institutions of Higher Education

Islamic Azad University
 Imam Sadeq(AS) University
 The Institute for Rural Development
 Imam Reza (AS) University
 The School of Ossoul Din
 Baqer Al-Oloum Higher Education Institute
 Ershad Higher Education Institute
 School of Hadith Studies
 Azarbaijan Institute for Accounting and Management
 The Iranian Institute for Industrial Research
 Khatam Higher Education Institute
 Khayam Higher Education Institute
 Mofid University of Social Sciences
 Raja Higher Education Institute
 Sura Higher Education Institute, Tehran
 Razavi University of Islamic Sciences
 Sajjad Higher Education Institute
 Sheikh Bahaei Higher Education Institute
 Shomal Higher Education Institute
 Shahid Motahhari Higher Education Institute
 Taberstan Higher Education Institute
 Shahid Ashrafi Higher Education Institute
 Mohhadeth Noori Higher Education Institute
 Karr Higher Education Institute

Nabi Akram Higher Education Institute
The School of Economic Affairs

Research Institutions

Asnad Research Institute
The Research Institute for Economic Affairs
The Institute of Research and Planning for Higher Education
The National Centre for Oceanography
The Research Institute for Social Sciences and Cultural Studies
Iran Polymer Research Institute
The Institute for Research on Planning and Development
The Research Institute of Education
The Research Institute of Meteorology and Oceanic Sciences
National Centre for Scientific Research
The National Institute of Forestry
The Research Institute of Occupational Health
The Research Institute of Bonyad Daneshnameh Bozorg Farsi
The International Research Institute of Earthquake Studies and Engineering
The Research Institute of Construction and Housing
The National Research Institute of Veterinary Sciences
The Research Institute of Earth Sciences
The National Research Institute of Genetic Engineering and Biological Technology
The Research Centre for Chemistry and Chemistry Engineering
The Research Centre of Dry Farming
The Research Institute for Children with Special Needs
The Research Centre of Cereals
Iran Research Institute of Minerals
Iran Research Institute of Telecommunications
The Great Islamic Encyclopedia
The Iranian Research Organization for Science and Technology
The Research Institute of Metrology
The Centre of Information and Scientific Documents
The Research Institute of Materials and Energy
The Research Institute of Nirou(Power)

Research Institutions affiliated to the Ministry of Health, Treatment and Medical Education

Ibn-Sina Research Institute for Biology , Biotechnology, Reproduction and Barrenness
The Research Institute of Medical Ethics
The Research Institute of Neuroscience (Kerman University of Medical Science)
The Research Institute of Metabolism and Glands, Isfahan
The Research Institute of Neuroscience
The Research Institute of Immunology of Asthma and Allergy
The Research Institute of Microbiology of Abdolvahab Alborzi
The Research Institute of Dentistry
The Research Institute of Cellular Science (Royan Research Institute)
The Research Institute of Biotechnology
The Research Institute of Tuberculosis and Pulmonary Diseases

The National Research Institute of Medical Science
The Research Institute of Pharmacology
The Research Institute of Metabolism and Glands, Tehran
The Research Institute of Digestion and Liver
The Research Institute for Skin Diseases and Black Leprosy
Daroupaksh Medical Research Institute
The Research Institute of Microbiology
The Research Institute of Endocrinology and Metabolism
The Research and Treatment Institute of Infertility , Yazd

*Akira Arimoto
Akihiro Asonuma*

1. COUNTRY PROFILE

The total land area of Japan is 377,708.09 square kilometres. The estimated population as of October 1, 2002 (based on the national census of 2000) was 127,435,000 consisting of 62,252,000 males and 65,183,000 females. This country is now shifting to having the largest aging population in the world, while having the smallest birth rate. The language used is mainly Japanese, though most people start to learn English during their secondary education.

The change in the Japanese society since Meiji restoration, more than a century ago, enabled it to show the earliest, as well as the most rapid modernization among Asian countries. Almost all areas of society now accommodate such traits as high industrialization, urbanization, mass expansion, information and technology orientation, and rational bureaucratic organization. The standard of education is high, as shown by the fact that mass expansion has been increasingly attained throughout the whole education system, including higher education. Education is highly valued among the people to the extent that the society is often called a degree-craic or credential society. This now extends to women who are getting higher academic degrees and possess more social power.

The political system is that of a democracy with three fully independent branches: parliament, an executive cabinet, and a judicial system. Through the post-war period, the political structure had remained stable. It is often said that Japan's growth has been promoted by an able and efficient bureaucratic administrative system, but now deregulation and administrative reforms are becoming an issue for the first time in 60 years since the war. Diplomatic relations with foreign countries are based on a defense alliance between Japan and the United States of America. Economically, Japan is a country with a free market economy, and notable as the country with the highest imports of raw materials and exports of manufactured products. Internationally, in terms of GNP and national income it is one of the largest among nations. It has rapidly become an economic power in the world due to high economic growth since the latter half of the 1950s. Particularly, since the latter half of the 1980s it has made great growth, to the extent that economic friction has developed between Japan and the USA, focusing on issues of the intrinsic economic structure of Japan. Furthermore, the Burst of the Bubble Economy during the late 1980s to around 1992 seems to be making a drastic transformation of the structure of systems of permanent employment and promotion by seniority. It also promoted governmental administrative and finance reforms. It is planned as part of curtailment of government fiscal expenditure and the policy of deregulation that the National Universities become corporations independent of the government from 2004.

2. NATIONAL EDUCATION SYSTEM

A dual-track school system coined in the pre-war period was reformed in the post-war academic reforms in accordance with the ideal of providing equal educational opportunity. The basic stream of educational system in the post-war period, known as *gakko-kyoiku-ho* (the School Basic Law), is as follows: elementary school at the primary stage (6 years); lower middle school at the early secondary stage (3 years); upper middle school at the later secondary stage (3 years); universities and colleges at the tertiary education stage (4 years, but 6 years for medicine, dentistry, and veterinary courses). Among these, the first nine years constitute schooling in elementary and middle schools comprise compulsory education. Children enter schools at the age of six, though before that age many of them go to kindergartens and/or nursery schools.

Additionally, there are schools for the blind, deaf, and those who are otherwise handicapped, at both elementary and secondary education levels; there are colleges of technology, special training colleges, miscellaneous schools at the upper secondary education level; and universities and junior colleges at tertiary level. A small portion of those who graduate from universities enter graduate school. Universities have graduate schools from *shushi-katei* (master's course) of two years; or *hakase-katei* (doctoral course) of five years which is divided into *shusi-katei* (master's course) or *hakase-zenki-katei* (the first two years of doctoral course) and *hakase-katei* (doctoral course) or *hakase-kouki-katei* (the second three years of doctoral course). An exceptional case is found at Tsukuba University, *hakase-katei* is not divided into two parts. In a decade, variations to the standard systems have been introduced: *dokuritsu-daigakuin* (independent graduate schools); *dokuritsu-kenkyuka* (independent graduate courses); *daigakuin-daigaku* (graduate school without undergraduate courses); and *rengo-daigakuin* (confederate graduate schools). These new types have been introduced since *Daigaku-Shingikai* (the University Council) drafted a recommendation in 1988 entitled "On making the university system flexible". Furthermore, *Senmon-Daigakuin* (specialized graduate schools) were inaugurated as graduate schools (master's course) aiming at training advanced professionals in 1999. However, the specialized graduate school was bound by the frame of the existing graduate school, and had difficulties in taking flexible educational organization. Then, the *Senmonshoku-Daigakuin* (professional graduate school) was introduced in 2003.

3. HIGHER EDUCATION SYSTEM

3.1 Types of Higher Education Institutions

According to the statistics of 2000 by MEXT (Ministry of Education, Culture, Sports, Science and Technology), there are the following number of Higher Education Institutions and students:

	Number of Universities	Number of Students
(a) daigaku (universities)	649	2,740,000
(b) tanki-daigaku (junior colleges)	572	327,680
(c) koutou-senmon-gakko	62	56,714

The division of the sectors:

(a) national sector universities	99	624,082
(b) junior colleges	20	7,772
(c) colleges of technology	54	49,897
(d) private sector, universities	478	2,008,743
(e) junior colleges	497	298,847
(f) colleges of technology	3	2,261
(g) public sector universities	72	107,198
(h) junior colleges	55	21,061
(i) colleges of technology	5	4,556

Correspondence schools:

(a) private universities	19	138,453
(b) private junior colleges	10	28,108
(c) hoso-daigaku (Open University)	1	81,258

3.2 Co-ordination of Higher Education

Of the various kinds of co-ordination bureaucratic, political, market-oriented, the most fundamental is that of governmental co-ordination provided by the Ministry of Education, which was reorganized by the Ministry of Education, Culture, Sports, Science and Technology (MEXT) in 2001, especially for private foundations. In relation to chartering academic institutions, for example, the standard for academic accreditation was originally made by *Daigaku-Kijun-Kyokai* (JUAA: Japan University Accreditation Association) and subsequently amended by an ordinance of the Ministry of Education which requires permission of *Daigaku Shingikai* (the University Council) when the Ministry of Education seeks any amendment. The Ministry of Education provides administration related to the foundation and accreditation of institutions after asking the *Daigaku-setti Gakko-hojin Shingikai* (the Council for University Chartering and School Trustees) about the standards of academic accreditation. The Ministry of Education also provides qualitative as well as quantitative control of Higher Education by conducting decision-making in regard to higher education planning on the basis of this administration of foundation and accreditation. It is also responsible for administrative guidance by inspecting universities and colleges by members of *Shigakukan* (Committee of School Inspection).

In matters of finance, the Ministry of Education co-ordinates the national sector by controlling the amount of funds provided to individual institutions; and also in the private sector by controlling amounts of subsidies provided to private institutions. Research grants as well are effectively controlled by the Ministry of Education, since most of them are allocated by the Ministry.

A trend of deregulation is increasingly recognizable among various Ministries and other relevant bureaucracies in the national government. The effects on the universities and colleges are to the extent that they can now enjoy more freedom than they ever had previously. Even so, nationwide implementation of academic reforms, an increase in the number of new establishments and restructuring of institutions offers greater opportunity of co-ordination by the Ministry of Education by strengthening its financial control through the enlarged allocation of funds to the selected institutions.

The Ministry of Education, the Bureau of Higher Education, the Bureau of Research Promotion, and the Bureau of Science and Technology Policy are mainly responsible for control and coordination related to universities and colleges. The Bureau of Higher Education, *daigaku-ka* (University Division) is in charge of accreditation and finance for the national universities and colleges; *shigaku-gyosei-ka* (Private Education Institution Administration Division) is responsible for accreditation and finance, and *shigaku-josei-ka* (Private Education Institution Aid Division) for private universities and colleges; *gakusei-ka* (Student Affairs Division) for student scholarship, *senmon-kyoiku-ka* (Special Education Division) for technology education, *igaku-kyoiku-ka* (Medical Education Division) for medical education, and *kyoiku-daigaku-shitu* in *daigaku-ka* (Department of Teachers Training Colleges in the University Division) for teachers training. The Bureau of Research Promotion, *kenkyu-josei-ka* (Research Aid Division) is in charge of research grants and *kenkyu-kikan-ka* (Research Institution Division) for research institutes and related organizations.

Today's most important organization responsible for academic administration is the *chuo kyoiku shingikai* (National Central Council of Education), though previously the *Daigaku Shingikai* (University Council), the *chuo kyoiku shingikai* (National Central Council of Education), and *Rinji Kyoiku Shingikai* (Ad Hoc Temporary Council of Education) had much more important positions.

3.3 Institutional Governance (on Academic Degrees)

Article 68-2 of *gakko-kyoiku-ho* (School Education Law), one of the ordinances of the Ministry of Education, states that degrees are to be conferred either by universities or *Daigaku-Hyoka Gakui-Juyo Kiko* (National Institution for Academic Degrees and University Evaluation). For degrees to be awarded, the recommendation is required of a committee of referees consisting of university professors and others having high quality of scholarship (*gakui-kisoku* Article 5) and more detailed procedures are defined in *gakui-kitei* [rules for degrees] in individual universities).

With regard to *gakushi* (bachelor's degree), the president approves decisions of academic staff meetings such as *gakubu-kyoujukai* (faculty meeting). In the case of master's and doctoral degrees, the president asks *kenkyuka-iinkai* (a committee of the graduate school) to examine an applicant after receiving the necessary documents including a dissertation. The Graduate School Committee usually establishes an examination committee and on the basis of their report it decides whether the university should confer the degree. The committee reports to the president who informs the applicant of the decision and sends a report to the Ministry of Education.

As indicated above, councils and trustees in universities and colleges are not substantially involved in the process of examination and conferment of degrees.

4. CHARACTERISTICS OF DEGREES AND DIPLOMAS

4.1 Types of degrees and diplomas

In this description institutions of Higher Education are restricted to universities, junior colleges and colleges of technology. Previously in Japan, degrees had meant only those of master's and doctoral level, and so bachelor's degrees were not included in the category of degrees until amendment of *gakui-kisoku* (Rules for the Award of Degrees) in 1991 when degrees came to

consist of bachelor's, master's, and doctoral degrees. At the same time, *Jun-gakushi* (associate degree) was introduced not as a title which is conferred to graduates from both junior colleges and colleges of technology. At the level of the doctoral degree, there are *katei-hakase* (doctorate by course work) which is conferred on those who graduate from a graduate school programme and *ronbun-hakase* (doctorate by dissertation) which is conferred on those whose dissertation has passed examination.

4.2 Title and abbreviation of degrees and diplomas

In Japan, no clear distinction is made between academic degrees and professional degrees, though it is occasionally true that master's degrees such as those in business management and education are generally considered to be professional degrees. Foundation of the professionals graduate school mentioned above aims at clarifying this distinction.

Titles of degrees were identified for degrees at the level of bachelor, master and doctor. For bachelor's degrees in literature, education, divinity, sociology, law, science, medicine, and engineering, based on article 34 of the former "*daigaku-setti-kijun*" (Standard for Universities and Colleges Charters). Master's degrees had 28 categories including such titles as *gakujuutsu-shushi* (M.A., M.Sc.), *bungaku-shushi* (master's degree in literature), *kyoikugaku-shushi* (master's degree in education), *singaku-shushi* (master's degree in divinity), *shakaigaku-shushi* (master's degree in sociology), *hougaku-shush* (master's degree in law), *rigaku-shushi* (master's degree in science), *ikagaku-shushi* (master's degree in medicine), *kogaku-shushi* (master's degree in engineering), based on the former "*gakuikisoku*" (Degree Rules). Doctoral degrees fall into 19 categories, including titles such as *gakujuutsu-hakase* (Ph..D.), *bungaku-hakase* (Doctor of Literature), *kyoikugaku-hakase* (Doctor of Education) based on the same rule (Suzuki, ed., 1980).

Such distributions of categories, however, were abolished by the amendment of *gaku-kisoku* in 1991, keeping only a framework of three kinds of degrees: bachelor's, master's and doctoral. But, even so, the new *gaku-kisoku* defined in article 10 that the name of the specialty will be provided as a supplementary note, and universities and colleges will decide the name of specialty to be noted.

4.3 Information contained in the document

Degrees may be awarded at three levels; *hakase*, *shushi*, *gakushi*. The highest level of degree is *hakase*, followed by *shushi* which is conferred on those who have completed the master's course or the first half of the doctoral course, and by *gakushi* which is conferred on those who have completed bachelor's course.

According to *gaku-kisoku* in Articles 10 and 11, the supplementary notes to the degree will include the name of its specialization and of institution conferring the degree. It is difficult to obtain an accurate figure related to the number of different specializations used by various institutions, since the initiative for deciding the names rests with individual institutions. According to a survey by *Daigaku-Hyoka Gaku-Juyo Kiko* in 2001, the number of specializations identified for degrees at the various levels are as follows: *hakase*, 216; *shushi*, 310; *gakushi*, 443. It was defined that only universities conferred *gakushi* degree and graduate schools conferred *shushi* and *hakase* degrees before the amendment of *gakko-kyoiku-ho* (School Education Law) and *gaku-kisoku* which took place in 1991; subsequently, *gaku-juyo-kiko* was introduced as an agency empowered to award degrees in addition to the universities and graduate schools.

5. STUDY PROGRAMMES

5.1 Number of credits

As *gakui-kisoku* (Degree Rules) states in Article 2, *gakushi* (bachelor's degree) is conferred on those who graduate from a university. Further *daigaku-setti-kijun* (Standard for University Charters) states in Article 32, qualification for university graduation requires a student to study in a university not less than four years and to obtain not less than 124 credits. Credits awarded per programme were changed greatly by deregulation of the *daigaku-setti-kijun* in 1993. The previous standard classified educational programs into four fields: general education, foreign languages, gymnastics, special education; it requires 36 or more credits in general education, which had three fields in humanities, social sciences and natural sciences; 8 or more credits for foreign languages; 4 or more credits for gymnastics, including lectures and practical work; and 76 or more credits in special education. Amendment of *daigaku-setti-kijun*, however, has abolished these separations, classifying only required subjects, elective subjects, and optimal subjects. Each university has been given more freedom to arrange its educational programs. According to *daigaku-setti-kijun* in Article 21, a credit consists of a programme which has content corresponding to 45 class hours: 15-30 class hours in case of lectures and seminars; 30-45 class hours in case of experiments, practical, and performance work. A class is usually expected to last for a term of 10 or 15 weeks; fewer weeks are occasionally permissible (*daigaku-setti-kijun* Article 23). Medicine and dentistry courses require six years and 188 credits; for veterinary science six years and 182 credits.

Master's degrees are conferred on those who graduate from a master's course as mentioned above. Qualifications for the award, according to *daigaku-setti-kijun* in Article 16, requires a candidate to have completed classes and not less than 30 credits, and to have satisfied oral and written examinations on a master's dissertation. For a candidate who is able to demonstrate outstanding achievement, only one year's schooling is necessary.

Doctoral degrees are conferred on those who graduate from a doctoral course (*daigaku-setti-kijun*, Article 4). Qualifications for the award, according to Article 17 of *daigaku-setti-kijun*, requires a candidate to have completed classes and directed study over a period of five years at graduate school (including two years at a master's course or first two year's of the doctoral course), to have obtained not less than 30 credits, and to have satisfied oral and written examination on a doctoral dissertation. For a candidate who is able to prove outstanding achievement, only three years study (including two years at a master's course or first two years of the doctoral course) is considered adequate. Notwithstanding the requirements for *ronbun-hakase* (doctoral dissertation) listed above, a doctoral degree may be conferred on a candidate who has not satisfied all the formal course conditions. In order for this to be done, a candidate would be required to demonstrate by examination in the graduate school, a level of academic achievement equivalent to those who have completed the programme of course work (*Daigaku-Hyoka Gakui-Juyo Kiko*, Article 4, Item 2).

5.2 Sequence of study

At undergraduate level, professional education as well as general and special education takes place. Within the four years of an undergraduate course, the first half in *Kyoyo-bu* (Faculty of General Education) has been focused on General Education and the second half in the Faculty of specialized education is focused on special subjects (not necessarily on professional education). It is recognized that professional education largely takes place as part of the specialized education,

though schooling gradually proceeds from general education to specialized education. Of course, this depends on the specialization: there are some specializations which have much professional education from an early stage and some which have less professional education. For example, professional education is emphasized in faculties such as medicine, dentistry, and teacher training.

Due to the introduction of the deregulation policy of the Ministry of Education in 1991, this traditional pattern, consisting of two years general education and two years specialized education, has been faced with revision by expanding the university's options in arranging its programme. One consequence has been the abolition of *Kyoyo-bu* (Faculty of General Education) established in the post-war academic reforms. This has gradually brought about expansion of specialized education to parallel the reduction of general education, though this has not necessarily led to more expansion of professional education. On the other hand, there is much opinion that general education should be stressed at the undergraduate level. In this regard, today is a time of groping when various experiments are being conducted in the academia over the arrangement of the curriculum and construction of programmes. This is clearly testified by the books and articles related to self-monitoring and evaluation (Cf. Arimoto ed., 1996; 2003).

It is defined in *daigaku-setti-kijun* in Article 3 that the master's course should aim at cultivating high ability essential for professions which need research ability and specialist expertise. The arrangement of an educational programme, however, is necessarily differentiated to a considerable degree according to university diversification and subject specializations. Today is a time of expansion of graduate schools, especially at the master's level where a trend toward professional schools is strongly recognizable: most graduate schools which have introduced new and notable reforms are stressing practical and professional education: for example, a typical case is seen in graduate schools for adult students and master's courses in management. However, on the other hand, it remains important that attention be paid to education in master's courses which retains a broad perspective and does not concentrate exclusively on specialization. This is why the new "professionals graduate school" started in 2003.

It is defined in *daigaku-setti-kijun* in Article 4 that doctoral courses should aim at cultivating advanced research and profound scholarship essential to researchers who will conduct their own autonomous research activity or highly professional work in a specialist field. The extent of specialization is higher in that research ability is stressed more strongly in a doctoral course than a master's course. But, the doctoral course has a similarity to the master's course in that the arrangement of the educational programme is diversified among universities and academic disciplines. It might be said that a doctoral course provides highly concentrated professional education because most of today's graduate from doctoral courses become researchers, but in this sense, the extent of the degree of professional education is less than that in a master's course.

5.3 Practical experience

It is stated in *daigaku-setti-kijun* in Article 25 that classes are to be conducted by lecture, seminar, experiment, practice, practical skill, or jointly by the use of all of these. A qualitative definition of these is given in *daigaku-kijun* (University Standard) and *daigakuin-kijun* (Graduate Standard) of *Daigaku-Kijun-Kyokai* (Japan University Accreditation Association) and such defined standards are referenced at the curriculum arrangement. But even so, no clear unified definition exists on the necessary extent of practical training and therefore interpretation of the term varies among universities and disciplines.

Concerning the undergraduate course, in junior and senior years (in school of medicine and dentistry 5th and 6th years) when specialized education is given, practical training is conducted in the forms of seminar, experiment, and practice. Credits for such practical training is authorized as a part of qualification for graduation. Especially, in such graduate schools as medicine, dentistry, and education, where professional education is emphasized, practical training or education practical skill constitute indispensable subjects. Clinical practice in schools of medicine is usually conducted in the 5th and 6th years for about forty weeks; in the Faculty of Education, teaching practice is conducted in junior and senior years for about four weeks; in schools of engineering, junior and senior year students are attached to *kenkyu-shitu*(research laboratories) where they are required to participate in practical training as part of a study held in *kenkyu-shitu*. Additionally, senior students take part in experiments, practical work, and seminars in their special subjects, since they are required to complete a graduate thesis even if it is not connected with professional education.

The extent of classes taught in lecture style is reduced in master's courses (the first two years of doctoral course) compared with undergraduate course so as to increase the weight of experiment, material collection, analysis, and dissertation writing in order to prepare their master's dissertations.

In the second three years of the doctoral course, students are mainly involved in practical training such as experiment, seminar, and practical work in order to prepare their dissertation. In other words, most post graduate education is devoted to practical experiences for training of researchers.

5.4 Grading and evaluation

Grading and evaluation of students is usually made by way of assessment of class attendance, examination, etc. The criteria for evaluation varies between universities and fields of specialization. It is true to say that both overall consensus can be seen among faculties and at the same time differentiation can be seen among them. The assessment may be embodied in various ways such as grades A, B, C, or scores from 0 to 100, or marking *yuu* (excellent), *ryo u*(good), *ka* (pass), *huka* (fail), etc. Whatever form it takes, credit based on such assessment is authorized as a necessary qualification for graduation.

As stated previously, qualification for master's and doctoral degrees principally requires credits in advance of passing an examination related to the dissertation. In the case of a bachelor's degree, students require credits and in some cases are required to write dissertations or complete research projects, both of which will constitute part of necessary credit. In other words, credit is treated as a number of total credits so that evaluation of credit is not directly connected with getting a degree. Accordingly, as far as the process of getting an advanced degree, perhaps a doctoral degree, is concerned, holding a degree from a previous stage is only a pre-requisite for admission; the final achievement depends on the outcomes of a series of theses and dissertations, at undergraduate, master's and doctoral level. There are differences in that obtaining the required credit is most important for getting a bachelor's degree, while completing an outstanding dissertation is most important for a doctoral degree, with the master's degree being intermediate between these two.

6. ADMISSION REQUIREMENTS

At the undergraduate stage, an entrance examination is taken for all universities except the open university. Examination mostly consists of a form of written test and interview. To a considerable degree, admission is based on a form of recommendation. A qualification for taking the entrance examination is graduation from senior high school, though there are many exceptions to the rules as described in *gakko-kyoiku-ho* (School Education Law) in Article 69. Generally, it is said that Japan's entrance examination is so difficult that there is even a word "*shiken-jigoku*" (examination ordeal) to establish it as a social problem; subsequently though it is fairly easy for students to graduate from universities and drop-out rate are raw. The difficulty and ease of admission, however, varies greatly among institutions. There are some institutions that effectively adopt open-door admission policies in order to fill a fixed enrollment, even if they require a formal entrance examination. In contrast, there are some institutions where the proportion of applicants to successful candidates is extraordinarily high: typical cases are found among prestigious universities (for example, universities such as Tokyo, Kyoto, Keio, Waseda, etc.) and also schools of medicine in national universities.

At the master's course level, an entrance examination is usually required. Candidates used to proceed directly to the graduate course from the undergraduate course at the same institution they graduated from but recently they are increasingly entering to graduate course at other institutions. Accordingly, more complicated entrance examinations are taking place at the graduate stage compared to those at the undergraduate stage.

For a doctoral course an entrance examination is held for admission to all full five-year courses, but when the course is divided into a first two-year part and the second three-year part, there are two procedures: a candidate who completes the required master's dissertation can subsequently proceed directly to the second part; or alternatively the candidates have to pass an entrance examination. Enrolling in the second part of doctoral course, candidates are usually required to take an entrance examination.

The main pattern of admission to universities is as follows. Commonly, a student takes a trial examination held by one of the special agencies for preparing students for the entrance examination such as *yobiko* (cramming school). Based on the results, the candidates decide to apply to several institutions. A written examination forms the main part of the entrance examination, while interviews and other exercises are used to some extent. Examinations are held over one or two days, either as preliminary or secondary examinations. All national universities and a number of private universities ask applicants to take the unified preliminary examination held by *daigaku-nyushi-center* (National Center for University Entrance Examination) in advance and then to take the secondary examination held by the individual institutions. The modal time for these examinations is in the months from January to March. Students usually apply to several universities and also to several faculties within them. Students usually seek admission to a faculty, but sometimes it is to a specific department or educational organization. After passing the examination, applicants are enrolled after paying entrance fees and tuition.

For the master's and doctoral courses, examinations are usually held twice in a year: first in the period September-October, and second in the period February-March. The practice for admission to graduate courses has become different from that at undergraduate level, especially in the field of science and engineering, in that a candidate usually makes contact with a professor, as a dissertation advisor, in advance of taking the examination and to identify which *kenkyu-shitu* he or she wants to belong after enrollment.

7. DEGREE CONFERRING AGENCIES

Degrees are conferred by individual institutions. A university president has the right to confer bachelor's degrees and the president of a university having a graduate school has the right to confer master's and doctoral degrees. The Ministry of Education receives reports of these awards from university presidents (*gakui-kisoku* Article 12). But, besides universities, as described above, degrees can be conferred by *Gakui-Juyo-Kikou* (National Institution for Academic Degrees) which was established in 1991 and was reorganized as *Daigaku-Hyoka Gakui-Juyo Kiko* (National Institution for Academic Degrees and University Evaluation) in April 2000. This agency confers bachelor's degrees to the following people: those who not only graduate from junior colleges and colleges of technology but also obtained additional credits in colleges and universities; and those who graduated from one of agencies defined as educational faculties by *gakko-kyoiku-ho* (School Education Law) including, for example, *kancho-shokan-gakko* (government-office-sustained schools). *Daigaku-Hyoka Gakui Juyo Kikou* (NIAD: National Institute of Academic Degree) is considered to be analogous to a university organization in the sense that it is a joint usage agency in which faculty members of national, public and private universities and colleges can participate, its work is conducted by these university- and college-related participants, and evaluation in the process of degree conferment is conducted by faculty members inside academic institutions as well as scholars and men of experience outside them.

8. ASSESSMENT OF HIGHER EDUCATION INSTITUTIONS

After having made an evaluation of institutions when they apply for membership, *Daigaku Kijun Kyokai* (Japan University Accreditation Association) as a trustee for private foundations is responsible accreditation of higher education institutions consisting of *daigaku* (universities) and *tanki-daigaku* (junior colleges). As of 2003, the membership comprised 253 universities, or 42.1 per cent of all universities, if we add the supporting membership of 300 universities to them, the total number becomes 553 universities, or 85 per cent of all universities. Before 1996, the unit of organization to be evaluated in attaining membership was the faculty, so that a university consisting of several faculties could obtain university-wide membership automatically on the basis of just one faculty. Since 1996, however, the association has performed mutual evaluation to a regular member. The number of the universities which have been evaluated mutually since 1996 is 111. The number of the universities which have been examined for the judgment of affiliation and have become a regular member is 101. The number of universities which have been evaluated under the present system is 295, which is over the half of the number of regular members.

It is often said, however, that the accreditation system has not functioned adequately for about fifty years since it was established in 1947 (Cf. Amano, 1994; Kitamura, 1986). It was considered that chartering and accreditation are the two vehicles of academic evaluation immediately after the war when the accreditation system as well as *Daigaku Kijun Kyokai* were first introduced. But accreditation has not been conducted well though chartering has functioned satisfactorily. In this context, it might be said that responsibility for maintaining quality, particularly after achieving chartered status, was devoted to individual institutions. Even so, various external evaluations of higher education institutions do occur as is shown by the examination-passing-industries such as *yobiko* and *juku* (cram schools) and the various indicators produced by journal dealing with recruitment and placement, and newspapers.

In general, chartering has been stressed more than accreditation. The Ministry of Education, which was reorganized by the Ministry of Education, Culture, Sports, Science and Technology

(MIXT) in 2001, is responsible for the standard of chartering. Granting chartered status has been decided on the basis of recommendation of the *Daigaku-setti-Gakko-hojin Shingikai* (Council for Chartering and School Trustees) to the Ministry of Education. In this sense, it is manifest that the Ministry of Education has been mainly responsible for the evaluation of higher education institutions, not only national and public but also private universities and colleges, particularly at the time of their establishment. It has also made evaluation of the national universities at the stage when they seek their annual financial support. This trend seems to be increasing under the situation today that equal budgetary allocations among institutions is being shifted to one of priority allocation. In addition to the process of chartering, private universities have also been evaluated by the Ministry of Education when they have restructured with quantitative regulation for enrollment numbers related to appropriation for financial support. There are also evaluations by the Ministry of Education through a system of school inspectors.

Under recent academic reforms, every faculty and department is individually and organizationally conducting self-monitoring as well as self-evaluation exercises to a considerable degree. It is natural to say that academia is making attempts to innovate itself in order to cope with social change. Putting this concretely, this trend is observable as an expectation that the Ministry of Education will pay much more attention both to selective allocation of the budget in order to provide for expansion of the graduate school; and to recognized approval of restructuring of institutions and organizations caused by academic reforms. Observing these results, it is clear that the Ministry of Education still has much power to control institutions nationwide in the overall evaluation process (Arimoto, 1996). The start of the evaluation by the third party (2001) is promoting such a tendency. Since the Ministry of Education thought that the self-evaluation by each university was inadequate, this third party evaluation system by *Daigaku-Hyoka Gakui-Juyo Kiko* (NIAD) was introduced. It seems that however, control of the Ministry of Education is becoming strong, because the evaluation result of *Daigaku-Hyoka Gakui-Juyo Kiko* is used for governmental financial resource allocation in spite of being third person evaluation. The Ministry of Education began to allocate the budget for a large-scale research project to the university in 2002 (COE-Center of Excellence budget), and began to allocate the teaching-project budget in 2003 (COL-Center of Learning budget). The Ministry of Education leaves distribution function of the COL budget to the *Daigaku Kijun Kyokai*. However, there is a tendency for the Ministry of Education to strengthen the influence in the whole university evaluation, as a result.

On the other hand, evaluation of educational programs of higher education institutions by not the government but the professionals organization also started. Japan Accreditation Board for Engineering Education (JABEE) began the professional accreditation in the engineering field in 2000.

9. DEGREES AND PROFESSIONAL COMPETENCE

A person who wants to get a medical doctor's license is required to pass a national examination for medical practitioners. Candidates qualified to take the national examination for medical doctors are not necessarily graduates (e.g., holders of doctors degrees) from a faculty of medicine or six-year medical school, but in fact, almost all candidates are degree holders. They take clinical training before graduation and 80 to 90 per cent of graduates from faculties of medicine and medical schools succeed in the national examination for medicine and dentistry. In general, graduation from these faculties and schools leads directly to professional status. It is institutionalized by *Ishi-ho* (the Law of Medical Practitioners) that those who have passed the

national examination engage in clinical research activity for two years after getting their license as medical doctors before they practice independently as a medical doctor.

It is necessary for a graduate who wants to become a judge, a public prosecutor, or a lawyer to pass the national examination for administration of justice. Again, though qualification for taking examination does not require an academic degree, a candidate is exempted from the preliminary examination if he or she holds an Associate or Bachelor's degree, or has credit for the subjects of general and liberal arts required by the rules. It is also necessary that a graduate who wishes to become a licensed tax accountant or a certified public accountant should pass a national examination. In this field, too, almost the same qualifications as well as exemptions are adopted as in the case of the examination for administration of justice. Most graduates (degree holders) from the faculties of law at universities are recruited to jobs other than those in these specific professions and accordingly, getting a degree does not lead directly to professional license. In the case of lawyers, a person who obtains a license can engage in practical activity for the first time only after graduating from a two year *shiho-shushusei* (student of the Legal Training and Research Institutes). The professional graduate school which just started in 2003 will change such a feature partially. In the field of law, Law Schools, which specialize in professional education in the legal field start in 2004. Graduation from Law School becomes the eligibility requirements for taking an a new bar examination, although graduation does not become judicial officer-related qualification acquisition as it is. In addition to Law School, Accounting School, whose graduation is eligibility requirements for an examination for becoming a certified public accountant, will also start, corresponding to the reform of the system of the examination for becoming a certified public accountant.

In the field of engineering, there are various kinds of national licenses. Some require a bachelor's degree as a qualification as well as credits for some subjects in the education program as conditions for taking the license examination. Some licenses exempt candidates from additional examinations if an applicant has such a degree; conversely, some licenses need a fixed term of field study after graduation from an undergraduate course.

As for licenses for teachers in elementary and secondary education, a precise description is given in *kyoshoku-menkyoho* (Licenses for the Teaching Profession). As a rule, graduation from universities and colleges, or obtaining a bachelor's and/or a master's degree, is required as a basic qualification. To obtain a license, an applicant should also get the required credits in universities. But, a license holder cannot become a teacher automatically: a candidate can only become a teacher by passing the examination for recruiting teachers for the local government schools, held by the local government, or for private schools, by the private schools.

10. INTERNATIONAL RECOGNITION OF DEGREES

Degrees awarded in foreign countries are usually recognized as a qualification for enrollment in universities and graduate schools in Japan. *Gakko kyoiku-ho* states in article 70 that those eligible for enrollment in graduate schools are as follows: "those who have completed a sixteen-year programme (eighteen years for qualification for a doctor's course in the field of medicine including dentistry and veterinary science) in school education on foreign countries". It also states in Article 70-2 with regard to master's courses that those eligible for enrollment in master's courses are "those who have been awarded a degree equivalent to the master's degree".

The number of international students is gradually increasing as a result of the national government's policy, issued in 1983, of intending to accept 100,000 international students by

the year 2000. The number of foreign students which stays in Japan as of May 1, 2002 is 95,550. Especially in recent years, exchange activity is becoming more and more lively with the introduction of programmes of short-term study abroad on the basis of mutual agreements between domestic and foreign universities on exchange of credits, even though this is not intended to focus on awarding degrees.

Japan's participation in the project of University Mobility in Asia Pacific (UMAP) has brought about much discussion on recognition of credits as well as the problem of financing in relation to programs of short-term study abroad. As a result, according to this project, agreements of exchange programmes are increasingly found among universities and colleges. Japan has yet to take part in a regional meeting about higher education research, diploma, and degrees in the Asia and Pacific area and it is natural to point out that present situation needs to be improved as soon as possible.

REFERENCES

- Amano, Ikuo. 1994. *Koto-Kyoiku no Nihonteki Kozo* (Japanese Structure of Higher Education) Tokyo: Tamagawa University Press.
- Arimoto, Akira (ed.). 1996. *Gakubu Kyoiku to Curriculum no Kaikaku* (Undergraduate Education and the Reforms of Curriculum) Research Institute for Higher Education, Hiroshima University.
- Arimoto, Akira. 1996. "Cross-National Study on Academic Organizational Reform in Post-Massification Stage." *Research in Higher Education*, No. 25, March 1996.
- Arimoto, Akira (ed.). 2003. *Daigaku no Curriculum Kaikaku* (University Curriculum Reforms), Tokyo: Tamagawa University Press.
- Arimoto, Akira and E de Weer. 1994. "Higher Education Policy in Japan", in *Higher Education Policy: An International Comparative Perspective* edited by Leo Goedgebuure, Frans Kaiser, Peter Maassen, Lynn Meek, Frans van Vught and Egbert de Weert, Pergamon Press.
- Ichikawa, Shogo (ed.). 1995. *Gendai no Daigakuin Kyoiku* (Graduate Education Today) Tokyo : Tamagawa University Press.
- Kitamura, Kazuyuki 1986. *Koto-kyoiku no Rekishiteki-Kosatsu* (Comparative Study On Higher Education) Tokyo : Tamagawa University Press.
- Daigaku-Hyoka Gakui-Juyo Kiko (the National Institution for Academic Degrees and University Evaluation). 2003. *Gakui ni hukisuru Senko-Bunya no Meisho* (The Name of the Major Field Appended to Degrees, (www.niad.ac.jp/info/major/index.htm), October 1, 2003).
- Daigaku Kijun Kyokai* (Association of University Accreditation). 1995. *Daigaku Kijun Kyokai Kijunshu* (Compilation of Standards by the University Accreditation Association).

- Daigaku Kijun Kyokai (Association of University Accreditation). 2003. *Kaiinnko no Uchiwake* (The items of member schools) (www.juaa.or.jp/main/frame09.html, October 1, 2003).
- Tachi, Akira (ed.). 1995. *Tenkansuru Daigaku Seisaku* (Academic Policy in Turning) Tokyo: Tamagawa University Press.
- Minshu Kyoiku Kyokai (Institute of Democratic Education). 1994. *Gendai no Koto-Kyoiku* (Higher Education Today) No. 357.
- Monbusho Koto-Kyoiku-Kyoku (Bureau of Higher Education, Ministry of Education). 1991. *Daigaku Shiryo* (University Documentation) No. 117.
- Monbusho. 2001. *Heisei 12 nendo Gakko Kihon Chosa Houkokusho* (Digest Statistics of Basic Survey on Schools, 2001) Tokyo: Ministry of Finance Press.
- Monbusho. 2001. *Heisei 12 nendo Wagakuni no Bunkyo Shisaku* (Policy on Education, Science Sport, and Culture, 2001) Tokyo: Ministry of Finance Press.
- Monbusho Koto-Kyoiku-Kyoku Kikaku-ka (Planning Division, Bureau of Higher Education, Ministry of Education). 1992. *Daigaku Setti Shinsa Yoran* (Bulletin of Review for University Chartering).
- Monbusho Daiijin Kanbo Somu-ka (Department of General Affairs, The Minister's Secretariat, Ministry of Education). 1996. *Monbu Horei Yoran* (Bulletin of Education Law) Tokyo: Gyosei Publishing Co.
- Monbusho Koto-Kyoiku-Kyoku Daigaku-ka Horei Kenkyukai* (Research Meeting for Law, University Division, Bureau of Higher Education, Ministry of Education) 1996 (Annually enlarged).
- Daigaku Kankei Jimu Teiyo* (Regulation for Clercal Work Related to University).
- Suzuki, Isao, (ed.). 1980. *Chikujo-Gakko-Kyoiku ho* (School Education Law in Detail) Tokyo: Gakuyo Shobo Publishing Co.

KOREA, REPUBLIC OF

Hyun Chong Lee

1. COUNTRY PROFILE

1.1 Location and area

Poised strategically in the northeastern part of the Asian continent, the Korean Peninsula thrusts in a southerly direction for about 1,000 kilometres. To the north are regions of China and Russia, while the Chinese mainland lies directly to the west. To the east, the peninsula faces the islands of Japan. With its north-south elongation, Korea separates the Yellow Sea from the East Sea. The Korean Peninsula and all of its associated islands its between 124° 11' 00" E and 131° 52' 42" E and between 33° 06' 40" N and 43° 00' 39" N.

The area of Korea is 221,607 square kilometres (about 85,563 square miles). At present, the land is divided into two parts: the Republic of Korea (South Korea) and the Democratic People's Republic of Korea (North Korea). The administrative area of the Republic of Korea is 99,237 square kilometres or about 45 per cent of the whole of Korea.

1.2 Population

In 2001, South Korea had a population of 45,985,289, a density of 475.6 persons per square kilometre.

1.3 Language

The Korean Language is spoken by more than 70 million people living on the Peninsula and its outlying islands as well as the 5.6 million Koreans living in other parts of the world. Speaking and writing the same language among the entire people has been a crucial factor in forming strong nationality. Korean, like Japanese, also includes a rich vocabulary borrowed from Chinese in the same way that many European languages include a large number of words from Latin and Greek derivations. *Han-gul*, the Korean alphabet was invented in 1446 by great King Sejong and his court, and consists of 10 vowels and 14 consonants which are used to form numerous syllabic groupings.

1.4 Social and economic development

Korea's economy has made an outstanding performance despite unfavorable initial conditions for development. Since Korea launched its first five-year development plan in 1962, real GNP has expanded by an average of more than 8 per cent per year. As a result, Korea's GNP grew from \$2.3 billion in 1962 to \$477.0 billion in 2002, and per capita GNP increased from a meager \$9,700 to \$10,013, all at current prices. The key to this success was the adoption of an outward-looking development strategy making exports the engine

of growth; a strategy that reflected Korea's insufficient natural endowments, its limited domestic market, and its abundant, well-educated, industrious manpower.

Because of the changing global situation, Korea's competitive edge in labor-intensive industries such as textiles, footwear, and parts assembly has been eroding. In these industries, Korea is facing much tougher competition from other developing countries. On the other hand, in trying to move into the high-growth technology market, it meets formidable challenges posed by the increasingly rapid technological advances being made by industrialized countries.

As of 2001, there were 6,801 research and development (R&D) related institutions in Korea, which included 188 public research institutes, 276 at universities, colleges and junior colleges, and 6,337 belonging to private enterprise. The total R&D investment increased from a mere 2.61 per cent of GNP in 1991 to 8.77 billion US dollars or 2.96 per cent in 2001.

In order to train technical manpower and expand employment in preparation for the advent of an advanced industrial society, Korea's manpower development programmes emphasize the better utilization of educated or trained manpower, the improvement of working conditions, the encouragement of constructive dialogue between labor and management, and the revitalization of labor unions. To increase employment opportunities, emphasis has been put on the development of skilled labor industries and high-technology industries and on increasing scientists and technicians through expansion of vocational and technical education to meet the needs of a knowledge-based society.

The living standards of the Korean people have substantially improved owing to the rapid economic growth during the past couple of decades. Because of such growth, however, Korean society has had to undergo in a short period the kind of changes that took place in the developed countries of the West over several centuries. This has caused numerous socio-economic problems, including the disintegration of traditional values, a widespread sense of relative poverty and other difficulties accompanying industrialization, urbanization and the breakup of the traditional extended family.

The Korean Government, keenly conscious of these circumstances, has adopted the building of a society capable of ensuring the well-being of the entire population as a major national goal. Various laws have been enacted to promote the welfare of the handicapped and the aged and to establish a social welfare fund.

2. NATIONAL EDUCATION SYSTEM

Korea's Education Law declares, "Every citizen is entitled to an equal opportunity to receive education regardless of his or her religion, sex, or socio-economic status." To realize this goal, the following types of institutions have been established:

- Elementary, middle, and high schools as well as colleges and universities
- Vocational schools and vocational high schools
- Civic schools and civic high schools
- Special schools for special education
- Kindergartens
- Other schools such as alternative schools

These schools constitute the foundation of the linear school system of the 6-3-3-4 type.

2.1 Kindergarten education

Kindergartens provide children of 3-5 years of age with proper environment to encourage physical and mental progress. The curriculum generally covers the five areas of physical, social, expressive, linguistic and inquisitive life. In its infancy, kindergarten education has mostly been initiated by religious, social, and private organizations. As a result, the enrollment rate has relatively been low. Consequently, to raise the enrollment rate, the government has enacted a legislative basis for kindergarten education, including the Kindergarten Facilities Standard Ordinance (1969), the Kindergarten Curriculum Ordinance (1969), the Kindergarten Promotion Act (1980), and the 1st and 2nd Promotion Plans for Kindergarten Education. To enhance the quality of education, the government has developed and disseminated teaching materials and tools, and created teacher training and administrative support system, thus establishing a basis for raising the level of kindergarten education comparable to that of highly developed countries.

2.2 Elementary education

Elementary education in Korea is free and compulsory and provides the general rudimentary education necessary in life. In contrast to the low elementary enrollment rate at the time of national foundation, the current rate has soared to 99.9 per cent, which means practically all children are provided with elementary education. Such a quantitative growth is due to the high educational zeal among the public and the appropriate educational policies of the government.

The heavy concentration of the school population in urban areas, however, has brought about overcrowded classes and oversized schools in cities which may hinder efforts to improve the quality of education. Accordingly, the government created an education tax in 1982 to secure financial resources for a better educational environment and to improve teachers' socio-economic status. As a result, the number of students per class dropped to 34.9 in 2002. Oversized schools were divided into smaller ones and the double shift system of classes has almost disappeared. The government will continue to strive to normalize elementary education.

2.3 Secondary education

Middle School Education

The objective of middle school education is to provide general intermediate education on the basis of elementary education. Entrance examinations to middle schools were abolished in 1969, and all applicants are allocated to schools near their residence by lottery. The curriculum is made up of regular and extra-curricular activities. Regular activities are divided into required and elective subjects. School activities should be on for more than 220 days year every year and each class lasts 45 minutes.

As of 2003, 99.9 per cent of elementary school graduates go on to middle schools. Free and compulsory middle school education was first introduced in 1985 to agricultural and fishing villages and will be extended to the entire nation within a few years.

High School Education

High school education aims at providing advanced general and specific education on the basis of middle school education. High schools are classified into academic, vocational, and other high schools - foreign languages, art and athletics, science high schools, and alternative schools.

Middle school graduates or those with an equivalent academic background may enter high schools. The period of study is three years and students bear expenses of education. Since 1974, admission into high schools in the equalized areas has been based on the results of a general selection examination, while schools in the non-equalized areas require individual admission tests. In 2003, the overall rate of admission into high schools reached 99.7 per cent of the middle school graduates.

However, according to the Education Reform promulgated on May 31, 1995, in addition to the grades earned on the selection examinations, schools can refer to many other factors in selecting their students. For instance, a comprehensive school life record will be one of them. Much greater opportunities to select schools shall be open to students. Besides, “private schools with self-supporting ability,” which can be operated and maintained by a school foundation and by money paid by the students, shall be given the autonomous right to set tuition fees and select students without financial aid from the government from 1998.

Students in academic high schools, where advanced general education is practiced, select a major in the natural sciences, and vocational training according to their aptitude and interest. But, most of them decide to concentrate on preparation for university application. Vocational high schools aim at providing advanced general education as well as vocational training in agriculture, technology, commerce, fishery, and oceanology. Beginning in the 1980s, vocational high schools have offered many benefits and emphasized diverse field training to promote a skilled labor force to cope with the rapid changes in industry and society.

In addition, foreign languages, science, art and athletic high schools have been founded to educate future leaders in these specific areas. With strong government support, these schools aim at identifying the gifted at an early age and developing their potential in these specialties to the maximum level.

2.4 Higher Education

The categories of higher education institutions in Korea are colleges and universities; teachers colleges and colleges of education; junior colleges, the Air and Correspondence University, open universities; and other schools (including seminaries). All higher educational institutions are under the supervision of the Ministry of Education.

Higher education aims at teaching and studying fundamental academic theories and their various applications as necessary for the progress of society and the global community, thus fostering personalities capable of leadership. The period of study for college education is four or six years depending upon the curriculum provided.

To facilitate localization, regional universities are provided with extensive support. To educate and supply the technical and industrial manpower needed for industrialization, regional technical high schools have been converted into junior colleges which educate students in science and technology with the financial support from the government.

Junior colleges are two- or three-year post-secondary programmes and are the direct result for the increasing demand for technical manpower attendant in rapid industrialization. Since being authorized in 1979, the number has grown to 158 with an enrollment of 925,963.

The purpose of junior college education is to produce middle-level technicians equipped with a solid base of theories and skills. Their specialized courses are grouped into technical, agricultural, nursing, fishery, sanitation, commercial and business, home economics, arts and athletics, and so forth.

High school graduates and those with an equivalent academic background may enter junior colleges. Since 1994, entrance to junior colleges has been determined on the basis of school achievement, scholastic achievement test, interview, and aptitude test. Also, 30-50 per cent of the freshmen quota is reserved for the graduates of vocational high schools in the same fields, craftsmen qualified by the National Certification system and workers meeting a specified amount of industrial experience.

3. HIGHER EDUCATION SYSTEM

3.1 Types education institutions

Institutions of higher education are divided into five categories, namely:

- (a) colleges and universities (national, public and private),
- (b) teachers' colleges and colleges of education (national),
- (c) junior colleges (national, public and private),
- (d) an air and correspondence university (national) and open universities (national, private), and
- (e) other types of institutions (private) such as seminaries.

Colleges and University

There are 44 national, 2 municipal and 154 private colleges and universities, forming a total of 200 four-year colleges and universities. In order to be classified as a college or university by the Ministry of Education and Human Resource Development (MOE and HRD), the institution must meet the minimum standards which the MOE and HRD require. In general, four-year colleges and universities provide programmes leading to a bachelor's degree. A number of colleges and universities have programmes in medicine, oriental medicine, and dentistry. These programmes are six years in length. And four-year colleges and universities may also have graduate programmes.

Teachers' Colleges and Colleges of Education

There are two types of teacher education institutions in Korea: teachers' colleges for training elementary school teachers, and colleges of education for training secondary school teachers, both offering four-year programmes. There are eleven teachers' colleges, one in each province or metropolitan city, all of which are national. Each college has an elementary school attached, where the students are required to complete at least four weeks of on-the-job training. Practice teaching or student teaching includes the observation of class instruction, actual teaching and the performance of administrative affairs dealt with every day.

Colleges of education are either national or private, the main difference being that the national colleges offer various advantages in addition to relatively lower tuition fees. Colleges of education organize their curricula autonomously, including liberal arts subjects, subjects for teacher, major

required subjects and elective subjects. They put emphasis on the specialization of future teachers. Each college of education has an elementary school, a middle school and high school attached, where the students are required to complete at least four weeks of on-the-job training. In the course of practice teaching, students perform the same things as the teachers' college students do.

Junior Colleges

Junior colleges: there are 158 junior colleges, 16 national and 142 private. Junior college enrolment represents approximately 23 per cent of the students involved in higher education. Junior colleges offer programmes in general categories: (a) commerce, (b) kindergarten, (c) engineering/technical (e.g. agriculture, fisheries, civil and electronics technology, (d) liberal arts, (e) nursing and health, and (f) textiles and design. The majority of programmes for the training of kindergarten teachers are offered by junior colleges although such programmes are also offered by a few four-year colleges and universities.

Their programmes are two years in length, with the exception of the fisheries/marine colleges which offer an additional six-month course for navigation practice, and the nursing programme which is three years in length.

The Air and Correspondence University

There is one air and correspondence university in Korea. The Korea Air and Correspondence University offers five-year bachelor's degree programmes.

Miscellaneous Schools

The category, miscellaneous schools, established by the Ministry of Education to indicate institutions which are highly specialized and are not broadly diversified in their academic programme. As a rule, these schools lack a sufficient liberal arts core or basic general education programmes to meet the standards for an accepted undergraduate college or university programme in Korea. They are predominantly theological or single-purpose institutions. Miscellaneous schools that have received Ministry of Education approval have four-year courses and the students receive a diploma on completion of their programme. Students from these institutions may be accepted for graduate level work by colleges or universities if their specialized training is adequate preparation for graduate level studies.

3.2 Co-ordination of higher education

Under the Education Law, all higher education institutions, whether public or private, come under the authority of the Ministry of Education and Human Resource Development. The Ministry of Education and Human Resource Development exercises control over qualifications of teaching staff, degree requirements, faculty standards for universities and colleges, curricula, regulation for the establishment and closure of institutions, fiscal review, inspection of facilities, and the establishment of the overall official quota of students for each higher education institution. A significant part of this control, however, is now being decentralized, thus enabling more autonomy for higher education institutions.

With regard to other matters, universities comply with decisions made by a consultative organization called the Korean Council for University Education (KCUE). KCUE has the following functions:

- Professional research in the management of colleges and universities,
- Professional research on the college entrance system and development of admission I formation,
- Formulation of policies to provide financial aid to colleges and universities,
- Development and dissemination of college curricula and teaching methods,
- Conducting institutional and programme evaluation (accreditation),
- Collection, development, and provision of materials on college education and higher education organizations worldwide,
- Developing and conducting programmes for administrative and teaching staff,
- Recommendations to the government on important matters relating to college education,
- Implementation of projects commissioned by the government, and
- Enhancing inter-university co-operation.

3.3 Institutional governance

The structure of institutions of higher education varies with the type of institution, type of establishment, size of institution, and major functions. Like other nations in the world, a higher education is a legal entity in Korea. Vision, educational goals, basic management, finance and composition of higher education institutions are prescribed by national laws and ordinances. Detailed matters regarding these are stipulated by internal regulations of each institution. The laws and regulations governing higher education include the national constitution, laws and acts, ordinances, school regulations, and by-laws of higher education institutions. The legal provisions deal with the legal characteristics, legal status, objectives and functions, and the basic structure of higher education institutions.

Of the higher education institutions, colleges and universities have the most complex organizational structure. It is made up of educational structure, research structure, policy and planning structure, administration and management structure, social service structure, and student structure. Of these structures, in connection with governance, the function or two structures (policy and planning, and administration and management) is as follows.

The policy and planning structure generally refers to the board of trustees and the planning committee, which are the supreme decision making bodies of a university. At present, national and public universities and colleges do not have the board of trustees system. The function and organization of the board of trustees, qualification and salaries of a trustee are stipulated in detail in the Private School Law. The board of trustees has several functions and duties as follows: (a) approving the budget, (b) ensuring that the budget is balanced, (c) appointing, supporting and assessing the performance of the president, (d) managing resources effectively, and (e) preserving institutional autonomy. In addition to the board of trustees, the planning committee constitutes a part of the policy and planning structure in a narrow sense. The planning committee is responsible for the establishment of and deliberation on the long-term development plan and facilities expansion of a university or college. The committee is under the control of the university president.

The administration and management structure is a general term for the school structure which supports the educational structure. In the case of national universities and colleges the composition of the structure is provided for in pertinent laws and ordinances, while private institutions have an administration and management structure similar to that of their national

counterparts. The head of the structure is the university president. In addition to being responsible for the efficient management of the university administration and supervision and command of the school staff within the power delegated to him by pertinent laws or board of trustees, he represents the university. The president of a national university is appointed by the president upon request of the Minister of Education and Human Resource Development while the president of a private university or college is appointed by the school foundation upon the approval of the Minister of Education and Human Resource Development after the decision by the board of trustees. It is noteworthy that the participation of faculty members and students is excluded in the selection of a university president.

4. CHARACTERISTICS OF DEGREES AND DIPLOMAS

4.1 Types of degrees and diplomas

There are five types of degrees and diplomas:

- (a) Certificate - the degree is awarded to those who complete short-term programmes such as computer or continuing education programmes offered by a university.
- (b) Diploma - the degree is conferred by miscellaneous schools, which is allowed to apply to graduate schools.
- (c) Bachelor's - the degree is awarded to those who meet all requirements in a four-year college or university.
- (d) Master's and doctoral - the degree is conferred to those who complete all required course work and pass a thesis or dissertation.
- (e) Others - in the case of a junior college, associate degree is awarded.

4.2 Title and abbreviation of the degrees and diplomas

Academic Degrees in Arts and Science

- Natural Science: B.S. (Bachelor of Science), B.Eng. (Master of Engineering), Ph.D. (Doctor of Philosophy)
- Social Science B.A. (Bachelor of Arts), M.A. (Master of Arts), Ph.D. (Doctor of Philosophy)
- Humanities: B.A (Bachelor of Arts), M.A. (Master of Arts), Ph.D. (Doctor of Philosophy)

Professional Degrees

- Medicine: B.M.S. (Bachelor of Medical Science), M.M.S. (Master of Medical Science), Ph.D. (Ph.D. in Medical Science)
- Architecture: B.S. (B.S. in Architecture), M.S. (M.S. in Architecture)

- Teacher Education: B.A. (B.A. in Education), Ed.M. (Master of Education) or M.A. (M.A. in Education), Ed.D. (Doctor of Education) or Ph.D. (Ph.D. in Education)
- Law: B.A. (B.A in Laws), M.A. (M.A. in Laws), Ph.D.(Ph.D. in Laws)
- Others: B.F.A. (Bachelor of Fine Arts), M.F.A. (Master of Fine Arts)

4.3 Information contained in the document

- Name in Full
- Date of Birth
- Major (course of study) and Type of Degree (M.A., Ph.D., etc.)
- Serial Number of Degree
- Name of Dean of Graduate School
- Name of University President

5. STUDY PROGRAMMES

5.1 Number of credits

The Korean undergraduate has the opportunity to experience a rich diversity of courses, curricula, student, faculty, and settings that stimulate and challenge individual growth. In general, it takes four years to complete a bachelor's degree programme. A high academic achiever approved by a university is able to graduate in three to three-and-a-half years. The baccalaureate degree is granted upon the satisfactory completion of 120-140 credit hours. In the case of medical school, however, the requirement of course works is 180 credit hours and it takes six years to complete the programme.

In most universities, a student is required to take at least 18 credit hours but allowed to take more than 21 credit hours per semester. Each university establishes the number of semester hours of course work required in each year of its curricula.

The programme for the master's and doctoral degree must include: a minimum of two years of study; the exact requirement to be determined in consultation with the major advisor; a minimum of 24 credit hours for the master's degree and 60 credit hours for the doctoral degree. In most graduate schools, they limit 12 credit hours per semester. Criteria for part-time status (those who have a job or who register only for the night-time programme) in the graduate school are available and a special regulation is applied

5.2 Sequence of the study

In the case of baccalaureate degree programmes, the curriculum is categorized into the "liberal arts courses" and "the major courses". Those courses are sub-categorized into "the required courses" and "elective courses". The required courses in the liberal arts include Korean language, writing, English, second language, computer, and so forth. The maximum number of credits for the liberal arts, for example, is around 30 credit hours, but it varies depending on the programme of the university.

In the major field courses, students are required to complete 20-40 credit hours of the required courses and to take 20-40 credit hours of the elective courses. In most universities, minor programmes are available to students in an undergraduate degree and must be completed simultaneously with the major degree programme. Minors constituted of course work from a single department may not be earned by students majoring in that department.

In master's and doctoral programmes the graduate school offers various programmes. The courses that a student takes are determined and are chosen in consultation with major advisor.

5.3 Practical experience

In recent years, many universities have constructed a strong relationship and co-operated with industry. For example, many industries provide facilities to a university and the university may provide researchers and ideas in order to maximize the effectiveness of research. In addition, some companies open an internship position for the senior students and some universities evaluate it as a credit. In the case of teachers' colleges and colleges of education, the students have to take at least four weeks an on-the-job training courses that offers two credit hours.

5.4 Grading and evaluation

Faculty members have a responsibility to provide the university and the student with an individual evaluation of each student's work. At the beginning of each semester, faculty members are expected to announce to their students the basis on which the final grade will be determined. In request, they provide students a review of all graded materials, including mid-term and final examinations, that contributed to the course grade and a review of the method by which the grade was determined. It is the right and responsibility of faculty members to determine and assign the grade for each student enrolled in their courses.

In most universities, grades of A, B, and C are assigned for satisfactory work. A grade "A" indicates distinguished mastery of the course material; a grade of B good mastery; a grade of C acceptable mastery. A grade of D indicates minimally acceptable achievement for credit; in some universities a grade of "D" in certain courses does not allow that credit to be applied toward the degree. A grade of F is failed.

A student's grade-point average is determined by the ratio of quality points earned to semester hours attempted. In general, quality points are assigned to letter grades using the following scale: A = 4 quality points; "B" = 3 quality points; C = 2 quality points; D = 1 quality point; F grades carry no quality points. In some cases, pass-fail option courses are offered. Such grading systems vary from university to university. Some universities specify the system such as A+, A- and so forth.

6. ADMISSION REQUIREMENTS

The admission requirements for the undergraduate school are designed to ensure that students who show promise of academic success are admitted to the university. The most important criteria of this potential are:

- (a) the grade-point average earned in a high school,
- (b) the score in a scholastic achievement test,
- (c) essay test score, and
- (d) interview results.

In an effort to broaden the autonomy of colleges and universities and to normalize examination-bound high school education, a new entrance examination system became effective in 1994 and continues to improve every year.

In determining college entrance, the new system gives more than 40 per cent weight to high school achievement. According to the 1995 Education Reform, national and public universities will select students based on selection data such as high school achievement, scholastic achievement test score, essay test, interview and so forth as of the 2003 school year. Separate entrance examination, which have focused mainly on Korean, English and mathematics and were administered by respective national and public universities as well as private universities, have been abolished.

The scholastic achievement test breaks down into five categories: language (Korean), mathematics inquiry, English, elective inquiry (social studies, science, vocation) and foreign languages all focusing on high mental processing skills and analytic ability. Various elective subjects will be added to the scholastic achievement test according to the trend in which common compulsory subjects are reduced, while elective ones are expanded in the new curriculum in high schools in 2005 academic year. After the 1998 school year, the reflection rate of school achievement will vary from university to university. It means that the 40 per cent minimum for school achievement will not be compulsory, and each university can decide the reflection rate of school achievement.

In some colleges and universities, some applicants are allowed to apply for special selection. In this case, his or her scores on the scholastic achievement test and high school achievement are the major determinants of eligibility. Students from farming and fishing villages and handicapped students can also be selected through special selection. The dates for examinations are set by the Ministry of Education and Human Resource Development in different groups so that each university decides its date at its convenience. Students are allowed to apply for as many universities as they choose, if they offer examinations on different dates.

To enhance the quality of education through improving the quality of teachers, in 1985 the government foundation, the Korea National University of Education, and has also required that teachers' colleges and colleges of education consider in their admission process the results of teaching aptitude and personality tests.

7. DEGREE CONFERRING AGENCIES

Degrees are basically conferred by individual institutions. A university president has the right to confer bachelor's degrees and the president of a university that has a graduate school also has the right to confer master's and doctoral degrees. In this case, each university reports candidates for the award of a degree or diploma to the Ministry of Education and Human Resource Development. The classifications of the degree award systems for higher education are as follows:

- The first stage of higher duration leads to a bachelor's degree or to a diploma. The bachelor's degree is generally awarded after four academic year-long study.

- The second stage is a period of post-graduate study that leads to a master's degree. The period of candidacy for the master's degree is two or more years of study beyond the bachelor's degree.
- The third stage leads to the doctoral degree, which is awarded in the three or more years of further study after the master's degree.

8. ASSESSMENT OF HIGHER EDUCATION INSTITUTIONS

The Korean Council for University Education (KCUE) is responsible for the evaluation of higher education institutions. The University Evaluation Project (UEP) conducted by the KCUE is based in the KCUE Act (Article 3 and Article 18) which was promulgated in 1984. The KCUE is the only inter-institutional consultative body among Korean universities and consists of members from all four-year universities (as of 2003, 203 members) nationwide.

The purposes of the UEP are: to pursue excellence in higher education, to stimulate an individual university to develop distinctive institutions and programmes, to evaluate the success of university goals, and reflect universities' self-evaluation. The UEP proceeds via self-evaluation by universities and on-site evaluation by the KCUE itself. The overall procedures of the evaluation are as follows.

The KCUE, (a) develops the criteria of university accreditation, (b) collects relevant data for assessment, (c) proceeds on-site evaluation procedures, and (d) finally announces the accreditation results. The university accreditation consists of comprehensive accreditation and department evaluation. The comprehensive accreditation refers to the evaluation of each university in terms of educational goals, curriculum, financial capacity, facilities including educational equipment, administration, students' academic achievements, and the quality of faculties' academic work; whereas, the academic programme evaluation considers the quality of each programme by the standards of educational objectives, curriculum, students factors, the quality of faculties, facilities, administration, and finance.

The comprehensive accreditation system was adopted from 1994 and all member institutions have been evaluated comprehensively during 1994-2000. A ten-year accreditation system in academic programmes evaluation was enforced from 1991. Currently, the second cycle of accreditations both for comprehensive accreditation system and academic programmes evaluation are ongoing.

9. DEGREES AND PROFESSIONAL COMPETENCE

9.1 Medicine

Those who complete all requirements in the school of medicine are required to pass a national examination in order to be a medical practitioner. Besides passing the examination, those who desire to be a doctor in a specialized area must complete clinical practice and be trained in a hospital. The period of internship is one year and for the residency, it is four years. In the case of internship, the applicant must pass the examination given by the hospital. Those who have passed the national examination and have taken the clinical practice trainee course are able to practice independently. In 2002, the new 8-year medical school system was introduced and 5 universities adapted this 8-year medical school system.

9.2 Engineering

There are various kinds of national licenses in the field of engineering. Those who graduate from four-year university and candidates for the bachelor's degree in the relevant field, or a person who completed a junior college programme and has more than two years field experience are eligible to apply for the First Degree Engineering Licence Examination - a person who graduates from junior college degree (Associate Degree) is eligible to apply. In both the first and second degree engineering licence examinations, the applicants must pass both written and field tests. The licence holders receive preferential treatment when applying for a job. In some cases, an employer who manages a special business has to employ such a licence holder.

9.3 Law

It is indispensable for a graduate who wishes to be a judge, a public prosecutor, or a lawyer to pass the National Examination for Administration of Justice. Qualification for taking the examination does not need to hold an academic degree, which means a degree holder is not entitled to professional practice after graduation. Those who have passed the national examination should be trained for two years before legal practice in the Legal Training Institute.

9.4 Education

Those who graduate from a school of education, who hold a master's degree from a school of education in a graduate school, who graduate from a department of education in an undergraduate school, and who complete required course work offered by the division of education can receive "the Second Degree for the Teaching Certificate". Those who hold an associate degree from junior college and complete relevant course work specified by the education law can achieve a "Teaching Certificate for Practice".

Persons who hold a teaching certificate and pass the examination held by the local government can only become a secondary education teacher of the public schools. To be a private school teacher, he or she does not need to pass the examination but has to hold the certificate.

10. INTERNATIONAL RECOGNITION OF DEGREES

According to the Presidential Decree of the Education Law, those who complete secondary education and further school education abroad qualify for higher education institutions. Degrees awarded in most of the foreign countries are usually recognized as a qualification for enrollment in graduate schools.

There exists no official national body responsible for issues regarding the recognition of the foreign degrees because of colleges to determine for their own purposes, as the policy on foreign degrees is not fixed at the national level. In recent years, student exchange programmes have been introduced more actively on the basis of mutual agreements between domestic and foreign universities. Most of them are intended to focus on exchange of credits. The exchange programmes of awarding degrees are still in process in Korea.

School System of Korea

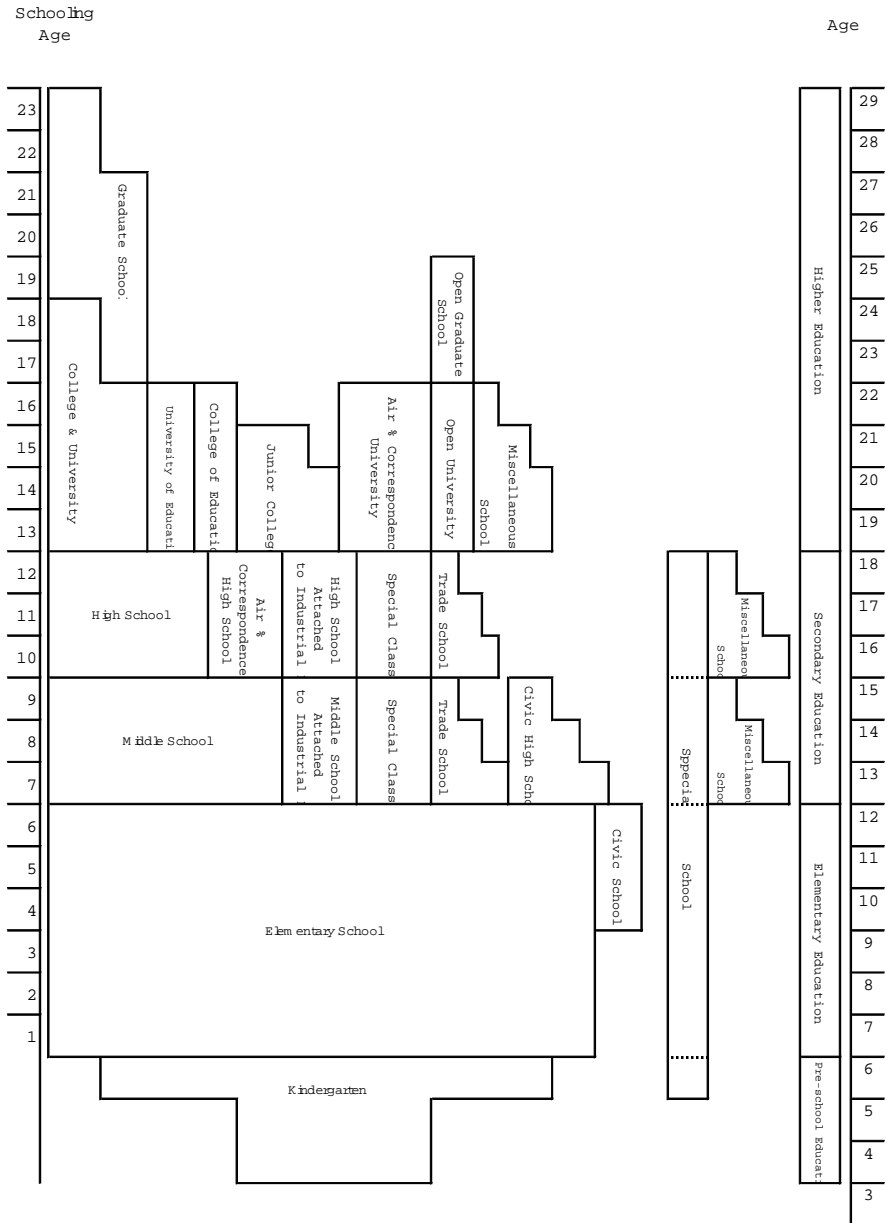

REFERENCES

- Lee, Hyun Chong (1998) *UNESCO Handbook*.
- Korean Council for University Education (2003). *KCUE Brochure (2002-2003) KCUE*.
- Korean Council for University Education (1990). *Korean Higher Education*, KCUE
- Korea University (2003). *Bulletin*, Seoul: Korea University Press.
- Ministry of Education (1996). *Education in Korea (1996-97)*, MOE.
- Ministry of Education (1995). *Education in Korea (1995-96)*, MOE.
- Korean Council for University Education (1986). *A Study on Higher Education I Korea*.
- Seoul National University (2003). *Bulletin*, Seoul: Seoul National University Press.
- Yonsei University (2003). *Bulletin*, Seoul: Yonsei University Press.
- Education Law* (2003). Seoul: Kyohak Press.

LAO PEOPLE'S DEMOCRATIC REPUBLIC

Phop Phannalath

1. COUNTRY PROFILE

The Lao People's Democratic Republic (Lao PDR) has a land area of 236,800 square kilometres, stretching more than 1,700 km from the north to south and between 100-400 km from the east to west that is situated on the Indochinese Peninsula of Southeast Asia. Laos is a mountainous and tropical rain forest country. About 70% of the land area is mountainous with highlands and plateaus. Tropical rain forest covers most of the country, especially in the east. The Lao PDR is watered by the Mekong River, from the northern to the southern frontier, approximately 1,860 km.

The Lao PDR has its eastern border of 1,957 km with the Socialist Republic of Vietnam, the western border of 1,730 km with the Kingdom of Thailand, the southern border of 492 km with the Kingdom Of Cambodia and the northern border of 416 km with the People's Republic of China and 230 km with the Union of Myanmar. Administratively, the country is divided into 17 provinces (including the capital Vientiane and a special zone) with a population of 5,253, 945 altogether; a density of 23 people per square kilometre (2002).

Lao is the official language, which has been used as the medium of instruction from pre-school to university level and also as the language of communication among multi-ethnic groups of people in the Lao PDR. In addition, foreign languages such as English and French are taught in most institutions, particularly from lower secondary school.

The Lao people consists of three main ethnic groups such as:

- Lao Loum (Low land Lao),
- Lao Theung (Upper Lao), and
- Lao Sung or Hmong (Hill tribes).

A Lao citizen has the right to believe or not believe in any religion. Most Lao Loums are Buddhists whereas Lao Theungs and Lao Sungs are mostly atheists. There are some Christians and other religions, too. As Buddhism has been the only pre-eminent religion in the Lao PDR for centuries, most Lao people are influenced by this faith, so they are frank, honest, patient and faithful to their families as well as their relatives and friends.

1.1 The Economy of the Lao PDR

Lao PDR is a developing country. It is rich in natural resources, but most of them are still unexplored, for example, iron, copper, gold, lead, sulphur, coal, etc. Presently, tin, rock and salt are being mined. Since the years, the government has taken steps to accelerate the transition of the Lao economy to a market based system and the Lao government has also tried to implement the New Economic Mechanism (NEM) which will accelerate the

transition of the economy from a centrally-planned economy to a market-oriented economy and the government has planned to promote Laos to be the center of trade for the Asian region. However, many problems have delayed the development, such as the following:

- Natural problems (draught and floods) which adversely affect agricultural production;
- Lack of technical expertise capable of exploiting natural resources;
- shortage of skilled manpower; and
- other existing problems.

1.2 International co-operation

Laos has been a member of the Association of Southeast Asian Countries (ASEAN) since 1998 and has related with the countries in the group in the areas of education and economics and now Laos is preparing to be a member of the WTO that is bringing in social, economic and education development to Laos.

2. NATIONAL EDUCATION SYSTEM

There has been a tremendous expansion of educational opportunities since 1995. The education in Lao PDR consists of three years of crèche, three years of kindergarten, five years of primary, three years of lower secondary school and three years of upper secondary school followed by post-secondary education with various programmes of one to seven years of duration as shown below:

Figure 1. Structure of the education system in Laos

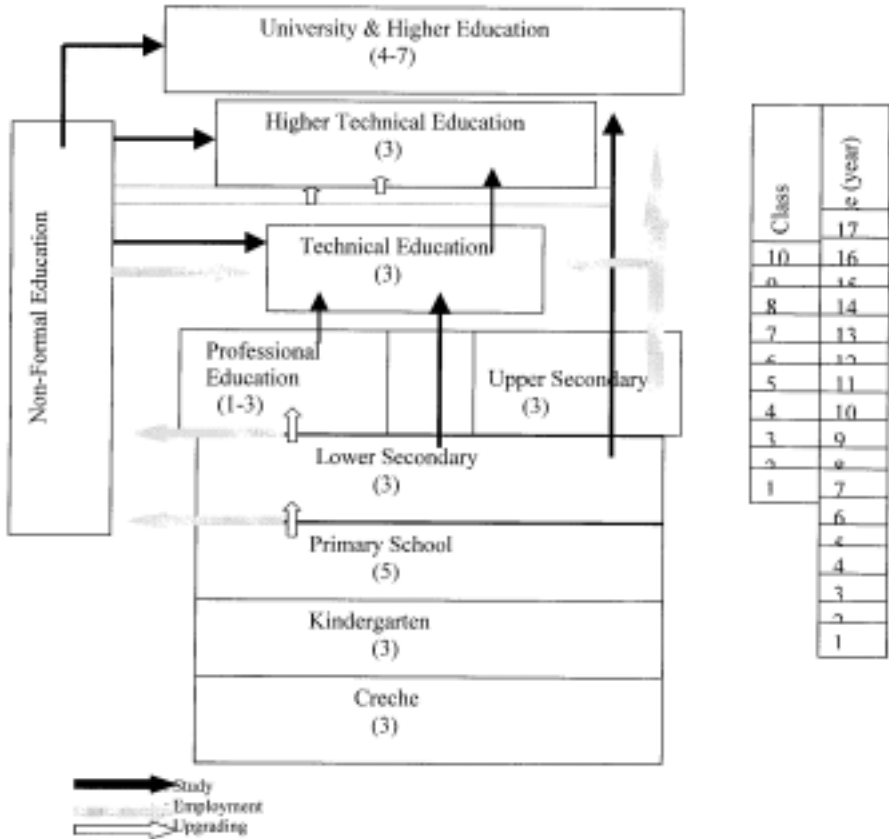

According to the data shown in the chart above, it indicates that:

- students aged 1-3 years can go to creche.
- students aged 4-6 years can go to kindergarten.

According to the data shown in the preceding chart, it indicates that:

- students aged 1-3 years can go to creche.
- students aged 4-6 years can go to kindergarten.
- students aged 6-11 years can go to primary school.
- students aged 12-14 years can go to lower secondary school.
- students aged 15-17 years can go to upper secondary school.
- students aged over 17 years can continue their further education at various levels, for example, technical education, higher technical education or university. This is determined by the students' abilities and course requirements and/or availability.

In addition, there is a limited provision for pre-school education enrolling, about five per cent of the age cohort three to five years old. But recently, according to the Lao government's policy of expanding education around the country and with help from foreign countries, many schools have been built all over the country, especially primary schools. So, at present, about 85 per cent of the age cohort six to eleven have enrolled at that level. But with lack of schools and teachers for secondary education, remote areas do not have enough schools and some live far from schools, that makes it very difficult to go to classes. That being the case, the percentage of student enrolment are still low. The gross enrolment ratio (GER) is 55 per cent at the lower secondary level, while it is about 30 per cent at the upper secondary level. Currently, there are three groups of post-secondary institutions in the country:

- The first includes three higher technical institutes and a university that offer programmes to a bachelor's degree level.
- The second includes seven higher technical institutes that offer advanced diplomas and are expected to offer degree programmes.
- The third group of 27 institutions are technical in nature and offer certificate programmes of one to three years in duration.

Apart from this, there is non-formal education offering three types of programmes:

- Literacy training for out-of-school adults.
- Upgrading programmes for adults.
- Upgrading programmes for government cadres.

These three types of programmes mentioned are evaluated once a year by the MOE. The degree granting post-secondary institutions and the "University" have been merged and organized into one institutional council (academic committee of each institution), referred to as the National University of Laos (NUOL), 1994.

2.1 Types of vocational and technical schools

The prescribed minimum years of previous schooling and duration of study in the vocational and technical schools are the following:

- Vocational schools (11 + 1-1.6 years, respectively), training workers, for example, at teacher education for kindergarten, accounting and nursing schools.
- Middle technical schools (11 + 3 years, respectively), training middle technicians, for example, middle polytechnic institutes, Pakpasak technical schools, medical college (11 + 2.6-3 years, respectively), and other technical schools.
- Higher technicals (11 + 3 years, respectively), training higher lever technicians as shown in Figure 1 (Structure of the National Education System in Lao PDR).

There are parallel streams of vocational and technical education and teacher training at the secondary level (All levels are upper secondary continual), each enrolling an equivalent of about 2% of the age cohort.

From the graduates of upper secondary education, about 18% proceed to institutes or "universities" and about 32% to various technical, teacher training institutes. The GER at the post-secondary education including technical school and teacher training is about 8%, while the GER for what can be regarded as higher or tertiary education is only 4%, according to data from NUOL.

The post-secondary education system consists of 37 small public institutions managed by the Ministry of Education, Ministry of Justice, one province and one municipality. Ten are offering or preparing to offer degree level courses (higher degree), while 27 are technical and vocational schools granting diplomas and certificates, and some others providing certificates that are not officially accepted .

There are also private education institutions offering programmes from kindergarten to lower secondary school vocational and technical training, for example, schools which offer computer science, accounting and foreign languages (English) in both short- and long- term training. Private education has been encouraged by the government since 1990. The number of private schools have increased rapidly (from 36% in 1990 to 90% in 2003).

2.2 Enrolment by gender

Table 1. Female and male enrolment as a proportion of total enrolment

Education Level	Percentage of female	Percentage of male
Primary level	60	40
Lower secondary level	55	45
Upper secondary level	52	48
Post-secondary level	40	60

The proportion of female enrolment for upper and post-secondary is quite low. There is a marked decrease in percentage for female students as the level goes up the ladder. The adult literacy rate is about 15%: 13% for males and 2% for females.

Compared with the 1996 situation, education opportunities have enormously expanded, but on the other hand, the quality of post-secondary education is low, partly because of the poor quality of education at the upper secondary level, which need to be supplemented by preparatory schools which are short of adequate programmes, facilities and qualified teaching staff. However, at the present, the education system is being developed in all aspects by the government, particularly by the MOE.

3. HIGHER EDUCATION SYSTEM

Higher education institutions are public and are managed by the government directly as mentioned above. Because of the government's policy for expanding education at all levels, there are many post-secondary education institutions that can award bachelor's degrees under the control of the Ministry of Education, for example, Comcenter College, Lao-American Language College, Seangsavan College, Latana Business College, etc., and many with limited provisions for vocational training by private schools. Some post-secondary institutions, such as the former Pedagogical University which is now the Faculty of Education, NUOL, offer non-formal education in various areas such as language training providing general English courses up to ESP (English for Specific Purposes) level.

All faculties/institutions which provide higher education are not formally equal in contact credits. For example, some subjects take more or less credits than the others. In addition, the study programmes of each institution/faculty varies in length as mentioned earlier.

The National University of Laos (NUOL) is a state-run university under the supervision of the Ministry of Education. Ten higher learning institutions (university-level institutions and higher technical institutions) located in Vientiane have been merged and reorganized into faculties in a multicampus national university. The curriculum in NUOL combines a two-year programme of foundation studies followed by specialized studies of three to five years depending on the faculty. NUOL consists of ten faculties: Education, Science, Economics and Management, Law and Administration, Engineering and Architecture, Medical Science, Agriculture, Forestry, Letters, and Social Sciences.

NUOL initially had four campuses: Dongdok campus, Sokpaluang campus, Phiavat campus and Nabong campus. Dongdok is the headquarters of the NUOL. The establishment of the NUOL needed external assistance in terms of finance as well as expertise. The Loan Agreement between Lao PDR and the Asian Development Bank was signed on 25 September 1995 for the Post-secondary Education Rationalization Project. The process of the establishment of NUOL has been carried out in an orderly and gradual manner in a duration of six years.

In 2000, after the transfer of higher learning institutions to the national university, the higher education institutions in Lao PDR are:

- National University located in the municipality of Vientiane offering Bachelor's Degrees and Diploma Courses;
- Teacher Training Colleges offering Diploma in Pedagogy located in Luang Prabang, Vientiane, Svanakhet and Champasak Province for teachers in lower secondary schools. In the future, these colleges will be transformed into "Regional Colleges" to better serve the community and also NUOL.

3.1 Co-ordination of higher education

The Ministry of Education (MOE) coordinates with the Board of Universities or Faculties. For example, the curricula for teaching programmes the different subjects are arranged in the university or faculty and sent for approval to the Ministry of Education. In addition, each faculty has a yearly conference, to review what they have taught and exchange ideas for adaptation and improvement, particularly their respective curricula.

The Department of Higher Technical and Vocation Education or HTVED (within MEO) is responsible for the management and co-ordination of the country's post-secondary sub-sector, including the overall supervision and monitoring.

3.2 Institution governance

The University of faculties at which the study programme is successfully completed confers the bachelor's degree. Students who perform satisfactorily in the final examination obtain a bachelor's degree from the University.

A ministerial decree delegates powers to the university's rector, or his delegate, to sign and award the bachelor's degree to the graduates. His/Her name and signature appears in the Bachelor's degree certificate. The dean of academic affairs of each faculty is also responsible for student selection and admission, student records, academic curricula development, programme accreditation and quality control.

4. CHARACTERISTICS OF DEGREES AND DIPLOMAS

4.1 Types of degrees

Higher education bachelor's degrees in the Lao PDR are certified by NUOL for all faculties and awarded to graduates by the University of the faculty. In every course programme in NUOL, professional titles are given to the graduates of a bachelor's degree. However, the number of learning credits of each subject in the study programme requirement varies depending on whether those subjects depending on their significance in the field of study.

No post-secondary institute awards degrees at Master's or Doctoral level in the Lao PDR at the present time.

4.2 Title and Abbreviation of the Degrees and Diplomas

Arts and Sciences

Natural science	B.Sc.
Social science	B.A.
Humanities	B.A.

Professional Degrees

Medicine	B.Sc.
Engineering	B.Sc.
Teacher Education	B.Ed.
Architecture	B.A.
Law	B.L.

Agriculture	B.Sc
Forestry	B.Sc
Irrigation	B.Sc
Electronics school	B.Sc
School of Communication and Transport	B.Sc

5. STUDY PROGRAMMES

There are prescribed numbers of credits for study programmes in the faculties. This means that the credit system is being used in Laos; teachers also have to follow the study programmes (curricula) which indicate the number of credits in each subject determined by individual faculty in each semester. Here is an example of the study programme of the Faculty of Engineering and Architecture: the length of study is 3-5 years (not including 2 years in the foundation school). The number of credits is 16 hours per week; different subjects have different credits (a minimum of 118 credits for a curriculum and a maximum of 163 credit (Academic Affairs Office, NUOL).

The number of credit in different subject are shown in the table below:

Name of Faculty	Credits per week	Semester includes the period of 2 years in FS (16 weeks/semester)	Length of Study
Faculty of Education	2 credits /week	6 semesters	3 years
Faculty of Engineering and Architecture	2 credits /week	6-10 semesters	3-5 years
Faculty of Economics	2 credits /week	6 semesters	3 years
Faculty of Medical Science	2 credits /week	6-10 semesters	3-5 years
Faculty of Agriculture	2 credits /week	6 semesters	3 years
Faculty of Forestry	2 credits /week	6 semesters	3 years
Faculty of Letters	2 credits /week	6 semesters	3 years
Faculty of Social Sciences	2 credits /week	6 semesters	3 years
Faculty of Science	2 credits/week	6 semesters	3 years
Faculty of Law and Administration	2 credits /weeks	6 semesters	3 years

After passing the entrance university examination, every student has to take 2 years in the school of foundation studies. They can continue to study at the faculty which they have applied for, however, it depends on the marks set by the faculty.

Table 2. Duration of study programmes

Title	Abbr.	Years to Complete	Semester Measures	Practical Experience
Medicine	B.Sc.	3-5	6-10	3 months
Engineering	B.Sc.	3-5	6-10	3 months
Teacher Education	B.Ed.	3	6	3 months
Architecture	B.Sc.	3	6	3 months
Law	B.A.	3	6	2 months
Agriculture	B.Sc.	3	6	2 months
Forestry	B.Sc.	3	6	2 months
Electronics School	B.Sc.	3	6	2 months
School of Communication And Transport	B.Sc.	3	6	2 months

The number of credits of each subject in each semester is different depending on which subjects are more important in the major area of study. For example, every engineering discipline has numerous subjects which can be taught, and the number of subjects is increasing day by day. However, it is not possible to cram all the subjects in a 3-5year study programme. The first priority is to teach those that are basic and which make up the foundation of the discipline concerned. These are called “core” subjects and must be taught to each student in his/her area of study.

5.1 Sequence and duration of study

A regular study programme may be comprised of at least 27 hours/week. In addition, students have to attend not less than 80 per cent contact hours of each subject per week.

The full-time course programmes leading to the university or higher institution degree are mostly 3 to 4 years' duration in engineering, teacher training, building and construction and agriculture fields. There are a few courses of a duration of more than 5 to 6 years such as dentistry, pharmacy and medical fields.

The sequence of the study is done step by step. Students have to spend 2 years at the School of Foundation Studies. As a rule, students follow their respective course programmes and take examinations during and at the end of each course unit. They graduate when they have accumulated the total number of required marks.

5.2 Practical experience

Practical training (PT) is an important element of a student's education. Its purpose is to merge the theoretical knowledge acquired during classroom instruction with specialized subject practice. During this period, the student is exposed to the actual conditions under which the various activities are practiced. In general, the objectives of the practical training are:

- to train students in the acquisition of various skills; e.g, the use of equipment and tools;
- to provide knowledge of materials, processes and human relations;
- to develop such abilities, as to plan and organize small projects and to communicate effectively;
- to foster responsible attitudes, such as an awareness and respect for work, and of thinking in terms of cost-effectiveness and efficiency.

In addition, practical training takes place in an appropriate subject environment, approved by the university and faculty. The total period for practical training is approximately 8-12 weeks depending on the subject and study programme of the university and faculty. Students divide their time between classroom and practical application in the local institutions in their field of study. Upon graduation, most students return to their home province to serve the needs of their community. Students should be visited at least once by institute staff during each practical training period and should be supervised by a training officer/engineer of the company/organization. A practical training period is normally considered as successfully completed only after the submission of a practice report, a logbook, and a training certificate issued by the company or employer.

A period of 8 to 12 weeks of practical training in an approved establishment must be accumulated by each student. They have to undergo practical training in a specialized area depending on the study programme. Some institutions prescribe different lengths of practical training.

5.3 Grading and evaluation

As a general rule, a subject consists of 32 hours = 2 credits per week which will be assessed at credits examination at the end of the semester. This assessment will normally constitute 60% of the total marks for this subject. The total marks shall be calculated using the following weight system: final semester examination 60%; continuous assessment (mid-semester tests, assignments, laboratory) 40%.

Normally, a pass in a subject requires a 50% overall mark (final examination and continuous assessment) but not less than a 40% mark in the final examination. However, for a laboratory subject, an average of 50% shall be accepted as a pass mark.

Individual courses are usually graded (mentioned below). Other grading systems exist and they are always explained in the document. The class of the title granted serves in many cases to indicate levels of achievement as measured in a given course programme. However, grading systems determined in each faculty are different from each other, for example, the class, other than the title granted serves in many cases to indicate levels of achievement as measured in a given course programme.

This is the grading system used in the former National Polytechnic Institute, now known as the Faculty of Engineering and Architecture. The final assessment of 3-5 years engineering courses, shall be based on a mark out of a 10, which is converted to a letter grade as follows:

- A :	4.0	high distinction
- B :	3.0	distinction
- C :	2.0	good
- D :	1.0	pass
	0	fail

A :	excellent
B+ :	very good
B :	good
C+ :	fairly good
C :	fair
D+ :	poor
D :	very poor
F :	fail

Fifty (50) per cent is the cumulative grade point average required for obtaining a degree.

6. ADMISSION REQUIREMENTS

Student admission to these institutions is based on a quota system and geared towards general education graduates of upper secondary schools or individuals who have completed their upper secondary vocational programme certificate and in some cases have at least two years of work experience. Institutional entrance requirements may also involve an entrance examination. It would not normally disallow an individual admission; rather, the examination is used for placement into a general education pre-entry year, or in some cases, directly into a technical programme or specialized subjects depending on the grade received.

Quotas are allocated to different programmes in the country. Students are then selected to fill the quota on the basis of nomination by the provincial authorities. Quota places are linked to scholarships given by the government. More recently, institutes have been able to accept additional students over and above those on the quota. Thus, at each institution, the student body comprises both quota students, who receive scholarship, and non-quota students who were non-quota varying considerably by type of institution. The number of quota students normally covers more than 2/3 of non-quota students in each academic year.

However, the university or faculties set their admission requirements and standards, which in the majority of cases, are only based on university or institution examinations and grades, mostly of individual course programmes, according to the entrance examinations. In addition, generally, minimum requirements for admission to degree programmes are at least 5 pass grades in both Mathematics and Physics. The following are guidelines for admission to universities and faculties:

- By contacting the Ministry of Education, each province may nominate a number of university candidates based on provincial population and demand. Students are selected according to secondary school academic scores and personal motivation. They account for approximately 60% of the incoming freshman class.
- Other interested students must take an entrance examination as part of their application to the University. This examination is open to secondary school from all provinces.
- Special admission may be granted to those personnel who graduated under one of the previous assistance programmes. For example, they are generally placed into the first or second year up to their ability of the professional subject.

The admission procedure is administered by the Ministry of Education.

7. ASSESSMENT OF HIGHER EDUCATION INSTITUTIONS

The University and faculties are considered public institutions and fall under the authority of the Ministry of Education, which guarantees the standard and quality of the education provided therein. No other assessments are made. From 1989, the Board of Universities and regional institutions have a greater responsibility for the evaluation of higher education than before.

There are various methods of continuous assessment of students during their periods of study, often combined with intensive forms of teaching and learning such as tutorials. Assessment processes are accompanied by thorough discussions and agreements between the University or faculty academic council. (The council consists of the president of council, the rector as vice-president, the chairman of the board of academic affairs, directors and department heads).

The aim of each faculty is to produce broad-based specialized graduates with a solid background of study. In order to assess the level of achievement of a student so that he/she may proceed to the next stage of studies, leading to eventual graduation, regular, periodic and formal assessments are required. The Ministry of Education is responsible for the assessment and accreditation of higher education institutions with the co-operation of the Board of Institutes. Besides this, the MOE responsibilities are to provide necessary support in its administrative and managerial

matters as each institution gains its full capacity in administering its own affairs under the direction of its council. This is referred to in the instructional programme of the Faculty of Engineering and Architecture.

Institutional requirements related to research, student class contact credits, student laboratory contact credits and the number of course preparations per semester vary from one faculty/department to another. Besides, institutions adopt their own approaches of assessment which fall into three categories: theory, practical training, and field work.

8. DEGREES AND PROFESSIONAL COMPETENCE

There are some requirements for practical training in some professions such as medicine, engineering, teacher education, law, etc. (during their study). For example, in the case of teacher education, students have to take 10 weeks of initial supervised teaching practice before they can take the final examination. This is necessary for a graduate qualified for a broad-based degree, so that he/she can fulfill wide ranging demands expected to arise in the future. This broad-based degree will provide graduates with strong background to work at both local and international projects in Lao PDR. At the same time, young and promising graduates will be encouraged to undertake post-graduate studies in foreign countries. Degree holders are entitled to professional practice in institutions in other countries and are entitled to professional practice after graduation.

In general, graduates from the Universities/Faculty take a test on professional competency in order to obtain a license to practice; a letter to certify that they successfully completed all the requirements for the degrees from their universities/institutes is also needed.

8.1 Awarding of degrees

A student who has successfully completed the programme of study shall be awarded the degree of Certificate, Diploma and Bachelor of subjects provided that he/she has also completed 8 or 10 weeks (determined by the Universities/ faculty) of certified practical training.

A degree with Honors shall be awarded to any student who has fulfilled the above requirements as well as the following :

- Not less than an A-grade in the final year project.
- Not less than a B-grade in each of the examinable specified subjects in the third and fourth years of study (This is an example of the Faculty of Engineering and Architecture).

9. INTERNATIONAL RECOGNITION OF DEGREES

Lao PDR is a signatory of the UNESCO Regional Convention on the Recognition of Studies, Diplomas and Degrees in Higher Education in Asia and the Pacific; however, at present it is in the process of ratification. The recent curricula of each faculty of the University is designed to produce internationally-recognized graduates, who follow three or four years study programmes. A diploma course which require four or five years of study, as was the case in the past, does not seem to fit any known international curricula of similar, recognized subjects of schools in the free market world.

Furthermore, it is clear that the new National University must immediately begin the right step academically if it is to have its institutions, faculties, departments, programmes and graduates recognized both regionally and internationally. An ensuing complication factor is that the National University may be starting “new” as a legal entity; however, it will in fact be an amalgamation of a number of post-secondary institutions of varying quality, efficiency and effectiveness.

1. COUNTRY PROFILE

For many centuries the beautiful land of Malaysia has drawn merchants, travellers, invaders and settlers to its shores in search of its fabled riches. With each new arrival, the melting pot of Malaysia's culture has been further enriched. The diversity of Malaysia's cultural heritage is matched by that of its landscape. The great mountains and rivers, the idyllic tropical islands, the palm-fringed beaches and the majestic rain forest make it a country of bountiful beauty and provide habitats for an amazing proliferation of wildlife and plant species.

Malaysia is approximately located on the longitude of 100'E to 118'E and latitude of 02' to 07'N. It covers an area of 329,758 square kilometres which include 135,598 square kilometers of Peninsular Malaysia consisting 11 states; Sarawak and Sabah are in the north of Borneo, Malaysia's two largest states, Sarawak occupies 124,449 square kilometres and Sabah 73,711 square kilometres. Singapore, Indonesia, Thailand, Brunei Darussalam and the Philippines are Malaysia's closest neighbours. Peninsular Malaysia is separated from East Malaysia in Borneo by 644 km of the South China Sea. Malaysia experiences a tropical climate with temperatures averaging 27°C year round with high humidity.

Malaysia's 23.27 million population (according to Population and Housing Census 2000), is a highly variegated ethnic mix. Generally, Malaysia's ethnic groups fall into two main categories: those with cultural affinities indigenous to the region who are classified as *bumiputra*; and those whose cultural affinities lie outside. Specifically, the ethnic ratio of the population is primarily the Malay and other indigenous 65.1%, Chinese 26.0%, Indian 7.7% and others 1.2%. In addition, more than 1 million international immigrants live in Malaysia to supply the much needed lower skills manpower resources. All of the world religions have substantial representation in Malaysia, notably Islam, Hinduism, Buddhism, Taoism, Christianity, thus main adherents of each are largely reflected in the multi-ethnic and multi-culture character of the population.

The national and official language is Malay as provided in the Federal Constitution while English is the language of administration and business. Chinese, Tamil and other dialects of indigenous groups are frequently used for social communication. Malay is the medium of instruction for national schools and public institutions of higher learning. Mandarin and Tamil are taught in schools along with other languages. About half of the population is multilingual and the literacy rate amongst Malaysian citizens aged 10-64 years was 93.5% in 2000, against 88.6% in 1991.

Peninsular Malaysia gained its independence from the United Kingdom on August 31, 1957; Sabah and Sarawak joined Malaysia on September 16, 1963. Malaysia is an active member of the United Nations and also a member of the Commonwealth.

Malaysia practices federal parliamentary democracy based on the Westminster model with a constitutional monarch. Since independence, The Alliance, then National Front consisting of United Malay National Organisation (UMNO), Malaysian Chinese Association (MCA), Malaysian Indian Congress (MIC) and other related political parties has continuously won the vast majority of seats and has been in control of the Parliament. This control has allowed Malaysia to develop economically in a politically stable environment.

The economy of Malaysia is mostly derived from natural resources: petroleum, liquefied natural gas (LNG), tin and minerals; agriculture: palm oil, rubber, timber, cocoa, rice pepper and pineapple and; industry: electronics products, electrical products, rubber products, automobile production and textiles. Malaysia has embarked on a visionary plan to set up a knowledge-based economy (K-economy). This programme marks a shift from the production-based economy (P-economy). The key feature of the K-economy is a highly educated labour force skilled in the utilization of knowledge as well as the application of information and communications technology (ICT).

In the first quarter of 2003, the country's labour force totalled 10.26 million and the total employment was 9.87 million (96.2%). Meanwhile, the unemployment rate stood at 3.8%, increased slightly by 0.3% from 3.5% in 2002. Despite a more challenging external environment, recovery of the Malaysian economy gained momentum in 2002; the Gross Domestic Product (GDP) surged by 4.2%, against a marginal growth of 0.4% in the preceding year. As for the year 2003, real GDP growth has the potential to be sustained in the region of 4.5%. No doubt that the financial crisis which started in 1997 had created constraints to the economic growth and per capita Gross National Product (GNP), Malaysia is still fundamentally strong and able to develop its manpower requirements and needs. The per capita GNP (at current prices) in 2001 was RM 13,333.

2. MALAYSIAN NATIONAL PHILOSOPHY

In the course of developing the country into a fully developed nation by the year 2020, Malaysia has developed the National Philosophy, the Rukunegara, as the national guidelines and country's aspiration of unity and development. Vision 2020 defines the present and future manpower needs of the country. These needs are sought to be fulfilled through successive Five-Year Development Plans in which tertiary education is expected to make a major contribution. The primary challenge of the country will be transforming the economy from one that is investment-driven to productivity and quality-driven through enhancing the efficiency of labour, capital skills upgrading, capital deepening and improving management and entrepreneurship.

2.1 *The Malaysian Education Policy*

The Malaysian Education Policy is the transformation of the National Philosophy. The main focus of the policy is on improving quality and increasing the quantity of out-put to meet the manpower requirements as well to produce citizens who are disciplined and have high moral values and good work ethics. The National Education Philosophy emphasizes the ongoing effort towards developing potentials of individuals in a holistic and integrated manner in order to produce individuals who are intellectually, spiritually, emotionally and physically balanced with firm belief in God. Thus Malaysian citizens are knowledgeable, competent, with higher moral standards, capable of achieving higher level of personal, family well-being and to contribute meaningfully to the society and nation at large. In addition, focus on national unity, production of manpower for economic and national development and nation building remain as important.

To this end, the Ministry of Education has taken steps to provide educational development programmes to produce knowledgeable, IT-literate skilled and noble citizens.

3. NATIONAL EDUCATION SYSTEM

Education as a whole is under the jurisdiction of the Ministry of Education with responsibility for managing a comprehensive school system ranging from Pre-school to university level, regulating syllabi, national examinations and supervising the overall development of education and training in the country. It has established departments and divisions within the Ministry to assist and coordinate the management of the national education. The main departments are currently Higher Education, Preschool, Primary and Secondary Education, Private Education, Special Education, Technical Education, Teacher Education, Moral and Islamic Education and several other departments to support the core activities, development of education policies and implementation. The structure of the Malaysian Education System is illustrated in Figure 1.

Primary education in Malaysia covers a total period of six years. It is aimed to provide a good foundation for pupils to be proficient in reading, writing and arithmetic (3 R's). At the end of the six years, primary school pupils will be assessed for the Ujian Penilaian Sekolah Rendah / The Primary School Achievement Test (UPSR / PSAT). Irrespective of their performance in the PSAT, all primary school pupils are promoted to Form One, the foundation year of secondary education. There are two types of national primary schools i.e. National Schools and National Type schools (Chinese and Tamil). A recent amendment to the Education Act 1996 has now made primary education compulsory beginning 2003. It is intended to ensure that equal rights to basic education for all children is better guaranteed.

Secondary education is the continuation of primary level education. The syllabi, Kurikulum Bersepadu Sekolah Menengah/Secondary School Integrated Curriculum (KBSM/SSIC) is developed to suit the needs and aspirations of the country. Secondary education is divided into three main levels: lower secondary level, upper secondary level and pre-university level.

Figure 1. Structure of the Malaysian Education System

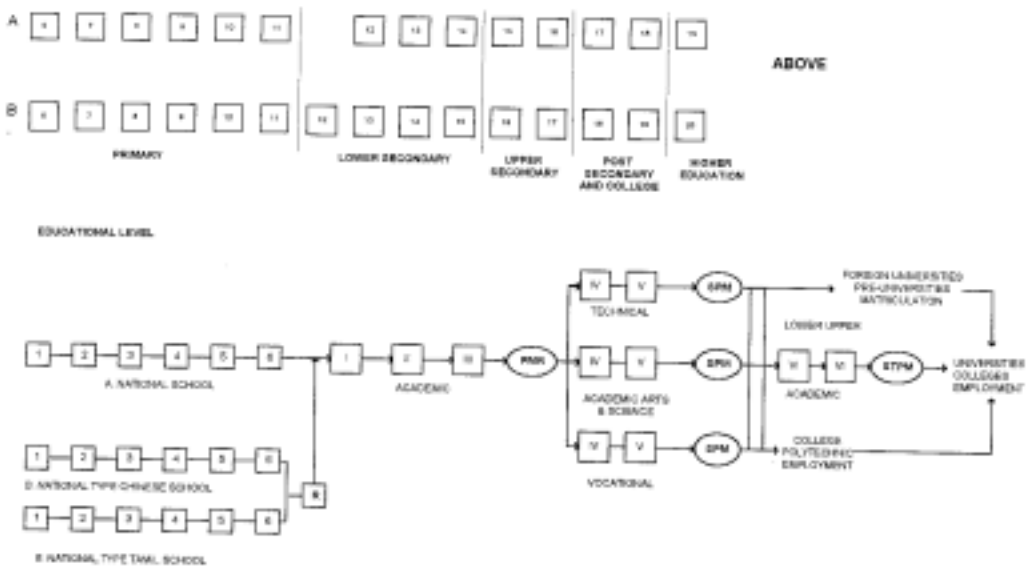

Source: Ministry of Education, Malaysia

Key :

- R Removal Class
- PMR Lower Secondary Assessment
- SPM Malaysian Certificate of Education
- SPMV Malaysian Certificate of Vocational Education
- STPM Malaysian Higher School Certificate

Lower secondary education in Malaysia prepares students to develop skills needed in life and to be useful citizens of the country. After completing the third year, the students are required to take a national assessment test, Penilaian Menengah Rendah/Lower Secondary Assessment (PMR/LSA). The students' performances in PMR/LSA will determine their academic streaming to the upper secondary level i.e., whether to be in science, arts, technical or vocational stream.

The selection of students and academic streaming to the upper secondary level will be determined by the Ministry of Education. Vocational subjects has been added to enhance living skills to Form 4 students. At the end of the two-year period in upper secondary education, the students will be assessed by a compulsory national examination, Sijil Pelajaran Malaysia/Malaysian Certificate of Examination (SPM/MCE) or Sijil Pelajaran Malaysia Vokasional/Vocational Malaysian Certificate of Examination (SPMV/VMCE), as in the case of the vocational streaming. The SPM / MCE/SPMV/VMCE certificates are equivalent to O-level Cambridge University Examinations. These national examinations is the responsibility of the Malaysia Examination Board established under Education Act 1996.

Students in the vocational course stream will study the vocational subjects in conjunction with other academic subjects identical to the normal school syllabi. They will be required to take the Peperiksaan Sijil Pelajaran Malaysia Vokasional (SPMV) at the end of the second year. Those with excellent results may further their studies at local institutions of higher learning or enter the

job market. Skills Training Course is an optional programme. Students will undergo the skills training programmes so as to enable them to sit for the Peperiksaan Majlis Latihan Vokasional Kebangsaan Asas (National Council for Vocational Training) at the end of the second year study programme. They will then join the job market or undergo advance skills training in selected areas or polytechnics. Vocational and educational training is given major focus to meet the high demand of skilled workers in the industry by the Ministry of Human Resource. Besides the Ministry of Education there are other ministries, public and private agencies involved in the vocational training of youth to fulfil the manpower needs of the industries.

The pre-university education programme is classified into two groups i.e., the A-Level and the matriculation study programmes. The entry to these programmes is based upon the performance in the SPM/SPMV. For the A-Level study programme, the academic streaming will be in arts, science and technical. Students will be required to take the Sijil Tinggi Pelajaran Malaysia Examination (STPM), which is organised by the Malaysian Examination Council and is accredited by the University of Cambridge Local Examination Syndicate of England (UCLES). The qualification is recognised by most universities around the world. In addition to STPM, the matriculation provides an alternate entry to bachelor programmes in public universities. They are conducted at the respective residential/private schools under the jurisdiction of the Division of Matriculation of the Ministry. It is a one-year academic foundation programme and students who excel in their examinations at the end of the programme will be accepted to the public universities. Private higher educational institutions also may also run similar foundation programmes which must be approved by the Ministry.

With rapid development in ICT, the Ministry intends to transform its education system in line with Malaysia's Multimedia Super Corridor (MSC) project and in support of the nation's drive to fulfil Vision 2020 by capitalizing on the presence of leading-edge technologies to stimulate thinking, creativity, and caring in all students by developing technology-supported Smart Schools. Besides the Smart Schools which were set in 1999 as nucleus for eventual nation-wide rollout of Smart Schools, strategies to intensify the use of ICT in teaching and learning at all levels of education has been put in place. By 2010, all 10,000 of Malaysia's primary and secondary schools will be Smart Schools.

Whilst the National Language Malay remain as the official language of instruction in the schools, a recent development in the Malaysian education system shows the importance of acquiring proficiency in the use of English. The Ministry has began to implement the teaching and learning of Science and Mathematics in English in 2003. It is expected that the teaching and learning of Science and Mathematics in English will be implemented fully at Standard 1, Form 1 and the Lower Sixth Form, commencing in 2003 and extended further in later years to the National Examinations, Matriculation college and polytechnics.

3. HIGHER EDUCATION SYSTEM

Institutions of higher learning in Malaysia provide opportunities to equip individuals with knowledge, skills and professionalism to meet the need of national human resources for national development. Both public and private institutions play important roles to fulfil the national needs. The increase in establishment of public institutions has been followed with parallel increase of private institutions ranging from kindergarten to university. Private college universities are a recent phenomena as private sector education has a role to increase access to tertiary education thereby complementing the public sector.

The private higher education institutions can be classified as private universities (full-fledged and university college) with powers to confer degrees and those institutes or colleges (without powers to confer degrees) which run various types of programmes and training from programmes equivalent to A -Level), home grown certificates/diplomas, professional courses and degree level programmes in collaboration with local or foreign institutions. The collaborations are generally in the form of twinning degrees arrangements, franchised or advanced standing arrangements in various disciplines.

4.1 Types of higher education institutions

The Higher Education Department of the Ministry of Education will co-ordinate and monitor the activities of institutions of higher learning in Malaysia, while the administration of polytechnics falls under the jurisdiction of the Technical and Vocational Education Division of the Ministry. The Private Education Department regulates the establishment and activities of private higher education institutions. Institutions of higher learning can be classified into three categories: polytechnic, college and university.

Polytechnics: Polytechnics were established in 1969 to provide training in engineering and commerce to students specialising in technical and vocational areas. The students graduate with diplomas and certificates. The entry requirements for polytechnics are the SPM/SPMV qualifications or equivalent. The full time programme for the diploma award is three years and two years for the certificate. Presently, there are *13 polytechnics*: Politeknik Port Dickson (Negeri Sembilan), Politeknik Ungku Omar (Perak), Politeknik Sultan Abdul Halim Mu'adzam Shah (Kedah), Politeknik Sultan Haji Ahmad Shah (Pahang), Politeknik Kota Bharu (Kelantan), Politeknik Kuching (Sarawak), *Politeknik Shah Alam (Selangor)*, *Politeknik Kota Kinabalu (Sabah)*, *Politeknik Johor Baru (Johor)*, *Politeknik Seberang Perai (Pulau Pinang)*, *Politeknik Dungun (Kuala Terengganu)*, *Politeknik Kota, Melaka (Melaka)* dan *Politeknik Kota, Kuala Terengganu (Kuala Terengganu)*. Institut Tun Hussain Onn, Batu Pahat is the training centre for the polytechnics' academic staff.

Colleges: Malaysia has 26 teacher training colleges. In addition a public college, i.e., Kolej Tunku Abdul Rahman (KTAR) was set up in 1969 and which offers certificate, diploma, advanced diplomas and pre-university programmes especially in the fields of commerce, applied science and technology.

Universities: Malaysia currently has 16 public universities established under Acts of Parliament and one international university. These institutions play a major role in the development of Malaysia. Malaysian public universities provide diplomas, undergraduate and post-graduate study programmes. The locations and the academic core areas of these universities are shown in Figure 2.

Figure 2. UNIVERSITIES IN MALAYSIA AND AREAS OF SPECIALISATION

Universities	Location	Academic Core Area
1. Universiti Malaya (UM)	Kuala Lumpur	Science, Humanities, Social Sciences etc.
2. Universiti Kebangsaan Malaysia (UKM)	Selangor, Kuala Lumpur, Sarawak.	Science, Humanities, Social Sciences etc.
3. Universiti Sains Malaysia (USM)	Penang, Kelantan, Perak.	Science, Humanities, Social Sciences and Technology
4. Universiti Putra Malaysia (UPM)	Selangor, Terengganu, Sabah.	Science, Agriculture and Technology
5. Universiti Teknologi Malaysia UTM)	Johor, Kuala Lumpur	Science, Technology & Engineering
6. Universiti Utara Malaysia (UUM)	Kedah.	Business Management & Accountancy
7. Universiti Malaysia Sarawak (UNIMAS)	Sarawak.	Specific to the need of the Development in Sarawak
8. Universiti Malaysia Sabah (UMS)	Sabah	Specific to the need of the Development in Sabah
9. Universiti Islam Antarabangsa (UIA)	Kuala Lumpur, Selangor	Science, Humanities and Islamic Studies
10. Institut Perguruan Sultan Idris	Tanjung Malim, Selangor	Curricula and Instruction
11. Institut Tun Hussin Onn (ITTO)	Batu Pahat, Johor	Technical and Vocational

Private Higher Educational Institutions

Presently, Malaysia still depends a great deal on foreign universities, especially those in the United Kingdom, United States, Australia and New Zealand to provide higher education for its students. A number of students pursue their higher education abroad while the rest continue locally. Currently there are more than 500 private higher educational institutions/centres/colleges, which are involved in the provision of some form of tertiary education, and of this number, 23 of them are engaged in collaborations such as “twinning degree programmes or franchised” mainly with universities in the United Kingdom, United States, Canada, Australia and New Zealand and with local public universities. The passing of a new legislation on private higher educational institution in 1996, the growth of the private sector education providers has increased rapidly. It has contributed to a major reform of the country’s higher learning with the establishment of full-fledged private universities such as Universiti Multimedia (MMU) (formerly known as Universiti Telekom) Universiti Tenaga Nasional (UNITEN), Universiti Teknologi Petronas (UTP), Universiti Sains dan Teknologi Malaysia (MUST), Universiti Antarabangsa Perubatan

(International Medical University) Universiti Tunku Abdul Rahman (UTAR) and newly established private university colleges such as Asian Institute of Medical Sciences and Technology (AIMST) Kolej Universiti Lim KokWing of Creative Arts, Kolej Universiti Pengurusan dan Teknologi Lanjutan and several others. In addition to this, several foreign universities have established branch campuses in Malaysia and they are Monash University Malaysia, Curtin University of Technology Sarawak, University of Nottingham Malaysia and FTMS-DeMontford Malaysia.

4.2 Coordination of higher education and Quality Assurance

Higher education in Malaysia has undergone a comprehensive change in the mid-1990s. The Ministry of Education has established the Higher Education Department functions as a secretariat which co-ordinates and monitors the activities of public and private universities and college education in addition to the important regulatory role of the Private Education Department. It is also directed to promoting Malaysia as a centre of excellence in education in the region. Prior to 1996, two laws regulated education in Malaysia, namely the Education Act, 1961 and the University and University Colleges Act, 1971. The parent Act i.e., the Education Act has now been replaced by The Education Act of 1996 and the latter, the University and University Colleges Act 1971 has been subjected to comprehensive amendments in 1996 promoting increased autonomy and efficient management. The other legislations also enacted in 1996 include the Private Higher Educational Institutions Act, 1996; Lembaga Akreditasi Negara Act, 1996 and the National Council for Higher Education Act, 1996. To meet the needs of funding for education led to the enactment of the Perbadanan Tabung Pendidikan Tinggi Negara Act 1997 (Higher Education Funding Authority Act) which provides loans to students pursuing higher education locally.

Overseeing the growth in higher education is the National Council for Higher Education. It is a body responsible for the planning and making of policy and strategy on higher education in this country, which consists of public and private institutions of higher learning. The Council will also become the one-stop centre for the determination and co-ordination of policy and strategy related to the development of higher education.

With the liberalization in the education sector and rapid increase of institutions providing higher education, the Government has put in place quality assurance machinery i.e., the Lembaga Akreditasi Negara (National Accreditation Board) which has been given the responsibility to assure quality of the provision of higher education and training in the private sector. It has been operational since 1997 and its main function is to set standards and criteria for quality assurance, recommend approvals to conduct and accreditation of courses of study and training, conduct of compulsory subjects at the registered private higher education institutions at all levels. Whereas for the public universities, they are currently subjected to quality audit at institutional or faculty level by the recently established Quality Assurance Division under the Higher Education Department.

4.3 Institutional governance

Each institution must coordinate its administrative functions to best serve its education mission. The structure of institutional governance is very similar among the universities and is defined in the Public Acts. The Vice-Chancellor is the chief executive officer of a university, assisted by the three Deputy Vice-Chancellors i.e., Deputy Vice-Chancellor for Development,

Deputy Vice-Chancellor Academic and the Deputy Vice-Chancellor for Student Affairs. The Registrar is the secretary to the university. The library is headed by the Librarian and the Bursar is in charge of money matters. All supporting staff are well-trained to carry out administrative functions. Detailed record keeping enhances the management of the institution.

Under the University and University Colleges (Amendments) Act, 1996, the highest authority of a university is the Board of Directors/Administrative Board (council) and the Senate. The Council regulates conditions of services for staff, maintaining the facilities and managing financial affairs etc. The university's Senate is responsible for the control and direction of academic programmes, research, examinations and has the power to award degrees, diplomas and certificates. The membership of each body is selected or appointed by various concerned authorities as stated in the University and University Colleges Act generally or the University's Statute.

5. CHARACTERISTICS OF DEGREES AND DIPLOMAS

Universities in Malaysia generally conduct courses leading to bachelor's and postgraduate degrees in areas of their specialization (core areas). Graduates are conferred their qualifications by their own universities as all universities are entitled by the Constitution to confer degrees. Currently, only Universiti Teknologi MARA (UiTM) and Universiti Teknologi Malaysia (UTM) are still conducting diploma level courses, together with the higher-end courses. Meanwhile, diploma- and certificate-level courses are gradually being absorbed by the polytechnics, Kolej Tunku Abdul Rahman (KTAR) and the private institutions of higher learning (PIHL) as illustrated in Figure 3.

Figure 3. DIVERSITY OF HIGHER EDUCATION INSTITUTIONS AND THEIR OFFERINGS

Institutions of Higher Learning	Postgraduate Degree	Undergraduate Degree	Diploma	Certificate
Universities	x	x	x	x ¹
Polytechnics		x	x	x
Universiti Teknologi MARA (UiTM)	x	x	x	x ¹
Kolej Tunku Abdul Rahman (KTAR)		*	x	x
Teachers College			x	
Private Institutions/Colleges	*	*	*	*and / or x
<i>Private Universities/ University Colleges</i>	x ²	x ²		
Professional/Examination Organisations			x ³	x ³

- x Academic awards conferred by the institutions
- x¹ Only Universiti Teknologi MARA (UiTM) and Universiti Teknologi Malaysia (UTM) still conduct courses for the certificate awards
- x² Academic awards conferred either by the institutions or by overseas universities, in the case of twinning or franchise programmes.
- *
- * Academic awards conferred by overseas universities under twinning or franchise programmes.
- x³ Awards or qualifications conferred by the professional or examination bodies

5.1 Types of degrees and diplomas

In spite of the variety of titles in academic awards, the generally accepted classification of the awards are: certificate; diploma; advanced-diploma; undergraduate degree of low standing; regular undergraduate degree; undergraduate degree of high standing; master's degree; doctoral degree; postdoctoral degree and honorary doctoral degree. All university graduates are conferred their degrees by the universities including the honorary degrees. The graduates from the private institutions of higher learning receive their awards from the institutions themselves for home-grown courses and degrees from their partner universities overseas. The polytechnics, ITM and KTAR confer their academic awards to their graduates. These qualifications are subject to the policies of the National Higher Education Council.

(Note: At the time of preparing this update the work has been undertaken by a National Technical Working Committee to develop the Malaysian Qualifications Framework which was initiated by the National Accreditation Board in early 2002. It has proposed levels of qualifications and its descriptors which have not been fully endorsed or accepted by the government. It is hoped that implementation will begin next year over a period of several years and it will have influenced over what has been described below.

Certificate A wide variety of certificates are issued by the public and private institutions. Usually, the duration of study ranges from a few months to two years and the courses focus mainly on certain levels of skill attainment, mostly in technical and business. As such entry requirements may differ. The certificates awarded are accepted by other institutions of higher learning as an entry qualification for diploma study programmes especially if entry to the certificate programme is SPM or its equivalent. Certificates may reflect a combination of study, training and examination or success on a single aspect.

Diploma For polytechnics, KTAR and private institutions of higher learning, diploma programmes are their main academic programmes. Study programmes are available in the various fields of professional, vocational/technical/technological, commerce and applied sciences. Among those are: business studies, technical studies, creative studies, hospitality, public relations, retailing, fashion, pre-professional etc. Entry requirements for the diploma is SPM/MCE/O-Level or equivalent. All universities provide a supplementary diploma course programme of six months to one year (postgraduate level) or courses of longer duration for the purpose of professional preparation or the further training of professions. The post-graduate diploma has an undergraduate degree prerequisite. Some professional bodies use the term diploma for professional membership and licensing, especially courses on vocational training conducted by these bodies.

Bachelor's Degree The bachelor award is conferred to candidates who have completed the bachelor's degree programme as stated in the university's publication. The most acceptable university entrance qualifications for the undergraduate studies are the STPM/A-Level/the residential school matriculation or equivalent. The duration of non-professional degree courses is normally three years while professional courses such as engineering, pharmacy, medical science and so on will take a longer period. In short, the study programme involves three to five years of full-time study, depending upon the subject

areas. The academic awards could lead to: first class degree, second class upper with honours, second class lower with honours and general degree. Such classification indicates the level of achievement.

Master's Degree The master's degree is awarded to candidates upon completion of a programme of advanced study of one to two years, beyond the undergraduate level. The study may have been in the form of courses and lectures or research programmes or of a combination of both. The normal minimum entry qualifications to the programme is a bachelor's degree with honours at least at second class level and the ability to pursue an in-depth study in a single field or a combination of fields plus the ability to pursue research or a project in the proposed field of study.

Doctoral Degree The abbreviation for the doctoral degree is Ph.D., notwithstanding the discipline to which it refers. Normally it requires at least three years or more of study programmes or research or a combination of both leading to the presentation of a thesis. The minimum entry qualifications for admission to a doctoral degree programme are a high level master's degree and the ability to pursue research in the proposed field of advanced study. In addition, the candidates will have to pass oral examinations (vivas) as well as, possibly, written ones. Other forms of doctoral degree are: Doctor of Surgery (D.Surg.), Doctor of Medicine (M.D.), and Doctor of Dental Surgery (D.D.S.). There are other doctoral degrees for outstanding contribution to knowledge, such as Doctor of Science (D.Sc.), Doctor of Letters (D.Litt.), Doctor of Laws (D.Ll.). Certain universities award to known scholars a doctoral degree on the basis of a published work; an honorary doctoral degree is awarded to individuals who have contributed either to the field of knowledge in an outstanding way without pursuing typical academic careers or to publicly well-known people of the political or other spheres.

Professional Qualifications

Professional bodies offer professional qualifications in the form of professional membership and licensing. In Malaysia, the professional qualification issuing bodies can be categorized into two groups i.e., Local Professional Examination Bodies and the External Professional Examinations Bodies. Some professional institutions are organizing their own schools, whilst others certify the academic awards provided by institutions of higher education, in the case of a joint effort between the institutions of higher learning and the professional bodies. The examination bodies are not teaching institutions but are councils which represent their specific skill or trade. The special committees are usually responsible for designing the syllabi and conducting the examinations. The local professional examinations bodies awarding the qualifications are: Certificate in Legal Practice (CLP); Malaysian association of Certified Public Accountants (MACPA); Pertubuhan Akitek Malaysia (PAM); Majlis Latihan Vokasional Kebangsaan (MLVK); and Institut Bank-Bank Malaysia (IBBM). The external professional examination bodies are: Association of Accounting Technician (AAT); Association of Costs & Executive Accountants (ACEA); Association of Business Executives (ABE); Association of International Accountants (AIA); British Computer Society (BCS); Business and Technician Education Council

(BTEC), Scottish Vocational Education Council (SCOTVEC); Chartered Association of Certified Accountants (ACCA); Chartered Institute of Marketing (CIM); City and Guild of London Institute (CGLI); Diploma in Management Studies (DMS); Higher Introductory Technology and Engineering Conversion Courses (HITECC); Higher National Diploma (HND); Institute of Administrative Management (IAM); Institute of Chartered Secretaries and Administrators (ICSA); Institute of Data Processing Management (IDPM); London Chamber of Commerce and Industry (LCCI); National Computing Centre (NCCI); National Council for Vocational Qualifications (NCVQ); Pitman Examination Institute (PEI); Royal Society of Arts (RSA) etc.

In other instances, many professional associations offer membership status ranks at the highest professional level to other persons as well as to university graduates. Other professional bodies organise their own examinations at the end of a course, typically a postgraduate part-time programme. Though the system of conferring professional awards by professional associations to graduates varies in procedure, it has contributed to the practice and development of professionalism especially in certain occupational fields. Professional qualifications recognized worldwide, especially from the Commonwealth countries are generally recognized by the Public Services Department, and other professional bodies in Malaysia.

5.2 Title and abbreviation of degrees and diplomas

Titles and abbreviation of degrees and diplomas awarded by the institutions of higher learning in Malaysia can be classified into three groups: bachelor's as the first degree; master's as the advanced degree and the doctorate as the academic degree. The title and abbreviation awarded is left to the faculties/schools to decide, but should be defined by the institution in its official publication. Most disciplinary groups confer the title and abbreviation for the bachelor's degree as: B.A., B.Sc. etc.; some signify the disciplinary groups: B.Soc.Sc. (Bachelor of Social Science) etc.; some in individual disciplines and fields: B.Bldg. Design (Bachelor of Building Design) etc; sub discipline: B.Eng. Electronics (Bachelor of Engineering-Electronics) etc; and some joint degree such as the Bachelor of Medicine and Bachelor of Surgery (M.B.B.S.) etc.

The master's degree is awarded to graduates who fulfil the necessary requirements upon completion of an advanced programme of one to two years. Usually, the title and abbreviation awarded for the programme are: M.A., M.Sc., M.Eng., M.Ch.E. (Chemical Engineering), M.Sc. (Struc.) etc.

The doctoral degree, notwithstanding the discipline to which it refers, requires at least three years of study. A candidate will be awarded the doctoral degree upon satisfying all credit requirements for the programme and obtaining an academic standing of excellence. A pass in all compulsory subjects and the presentation of a thesis are also required. The usual title for the doctoral degree is Ph.D.

5.3 Information contained in the document

It is important that the information provided in the documents recognize the value of truth in advertising when promoting or publishing any information concerning various kinds of academic awards. Publications must be prepared and presented in a professional manner to reflect favourably upon the institution. Information published must be accurate and factual and reflects the current status of the institution. When publishing a catalogue, institutions should keep in

mind the reading public for which such a publication is intended. Usually, the documents will list the following kinds of information: the award and the title conferred; the class of title; the field of study or course programme; arrangements other than full-time courses; the awarding institution or agency; the institution which has provided the course programme; prerequisite courses etc.

6. STUDY PROGRAMMES

The study programmes of an institution clearly relate to the purpose of the institution, and the programmes of the degrees, diplomas and the certificates which it awards. This relationship between purposes and programmes must be demonstrated in the policies of admission, content of curricula, requirements for graduation (quantitatively and qualitatively) and instructional methods and procedures.

6.1 Semester system

Most institutions of higher learning in Malaysia apply the semester system, varying in degrees of differences. The semester session is scheduled for May and October, though certain universities are registering the March semester as the normal academic calendar. The semester system may differ in the private education sector. Generally, each semester ranges from 16 to 17 weeks (including three examination weeks by the end of each semester) and eight to ten weeks for the March semester.

6.2 Academic award requirements

Each student upon registration has to fulfil minimum credit hours within a given period of time in order to qualify for a specific academic award. Generally, the minimum requirements which must be fulfilled en route to achieving an academic award are as depicted in Figure 4.1.

Most professional study programmes require an additional time for practical training which differs between professions. Usually, practical training is a partial requirement of the study programmes. All medical students have to complete their pre-clinical assessment before entering the internship practical.

6.3 Grading and evaluation

Although the structure of student grading differs between universities, generally, the students' achievement and grading system can be best explained in Figure 4.2. The academic award title granted serves in many cases to indicate levels of achievements as measured in a given study programme. Usually, awards given to graduates of a degree programme can be classified into: first class honours, second class upper (honours), second class lower (honours), third class or general degree. For the postgraduate awards, classification can be made into: master's in areas of study (M.A./M.Sc./M.Eng. etc.) and the doctorate in the areas of study (Ph.D). The general revision of the awards is shown in Figure 4.3.

Figure 4.1. GENERAL ACADEMIC REQUIREMENTS

Institutions of Higher Learning	Postgraduate Degree	Undergraduate Degree	Diploma	Certificate
Universities	x	x	x	x
Polytechnics		x	x	x
Institut Teknologi MARA	*	*	x	x
Tunku Abdul Rahman Kolej		*	x	x
Teachers College			x	
Private Institutions / Colleges	*	*	*	* and / or x
Professional Organisations			x*	x*

* For example, minimum credit for an engineering course is 120.

Figure 4.2. MARKS, GRADES AND GRADE POINT DISTRIBUTION

Marks Obtained	Grade	Grade Point
85 -- 100	A	4.0
80 -- 84	A-	3.7
75 -- 79	B+	3.3
70 -- 74	B	3.0
65 -- 69	B-	2.7
60 -- 64	C+	2.3
55 -- 59	C	2.0
50 -- 54	C-	1.7
45 -- 49	D+	1.3
40 -- 44	D	1.0
00 -- 39	F	0.0

Figure 4.3. ACADEMIC AWARDS AND QUALIFICATIONS

Diploma Programme	GPA Grading
First Class Diploma	GPA > 3.70
Second Class Diploma	2.00 < GPA < 3.70
Undergraduate Degree Programme	GPA Grading
First Class Honours	GPA > 3.70
Second Class Upper Honours	3.00 < GPA < 3.70
Second Class Lower Honours	2.30 < GPA < 3.00
Third Class or General Degree	2.00 < GPA < 2.30
Postgraduate Programme (Master's/Ph.D.)	GPA Grading
Qualified to be Awarded	GPA > 3.00
Conditional Pass (not qualified to be awarded)	2.70 < GPA < 3.00
Fail	GPA > 2.70

7. ADMISSION REQUIREMENTS

The admission policy of a university is the responsibility of the faculty/school, the administration and the governing board. The policy is clearly expressed and openly published. The individual or agency responsible for administering this policy is the Admission and Record Unit of the Registrar's Office. The admission requirements, both quantitative and qualitative, are always related to the purposes of the university. Since universities and colleges vary greatly in their purposes, it is logical that admission requirements likewise be different.

Generally, candidates wishing to pursue studies at Malaysian universities should possess the academic qualifications required by the university. Applications from candidates who do not possess the academic qualifications as stated by the university will not be considered. The admission requirements will be classified into two parts i.e., the general and the academic programme requirements.

7.1 General requirements

Language Candidates wishing to enter the university must have obtained a satisfactory standard of Bahasa Melayu/Malay both written and oral, and must have acquired sufficient knowledge of the English Language.

Health Candidates will only be accepted by the university if they are certified healthy by a medical officer from any government or private hospital/clinic.

7.2 Academic programme requirements

Postgraduate Courses

The postgraduate programmes are classified into: doctoral in philosophy, master's degree programme and post-graduate diploma. The entry

qualification requirements for the doctoral programmes are: a high level master's degree from the university or from any institution of higher learning recognized by the university's Senate; other qualifications equivalent to a master's degree with work experience acknowledged by the university's Senate; or candidates pursuing a master's programme at the university with the recommendation of the postgraduate committee of the faculty will be considered, subject to the approval of the Senate. Entry qualifications to the master's degree are: a bachelor's degree with good honours from the university or any institution of higher learning recognized by the Senate; other qualifications equivalent to the bachelor's degree and working experience in the relevant fields acknowledged by the Senate. For the post-graduate diploma, the entry qualifications are: a bachelor's degree from the university or equivalent qualifications; or other qualifications and experience acknowledged by the Senate.

Undergraduate Courses

The entry qualifications for an undergraduate programme are good results in STPM/A-Level or its equivalent, with credits in Bahasa Melayu/Malay in SPM.

Diploma Courses

At least a second grade in SPM or its equivalent; with credits in at least three subjects, Bahasa Melayu / Malay, mathematics, and one other subject; and such qualifications generally must be obtained in one examination.

Most postgraduate and diploma programmes are admitted under an open admission policy. Applications are directly sent to the concerned universities but applications to the bachelor and integrated courses are centralized through Unit Pusat Universiti (University Centralised Unit), organized and co-ordinated by the Ministry of Education Malaysia. The Unit will select the qualified candidates and allot their places to the relevant universities.

8. ACADEMIC FUNDING

Since the corporatisation of public institutions of higher learning, the government has reduced financial assistance to public IHL by 46 per cent across the board. The students have to settle the registration fees of about RM 1,600 per semester, which was previously fully sponsored by the government. The National Higher Education Fund Corporation (NHEFC) was created to assist student funding to institutions of higher learning. For the 1997/98 academic session, 9,091 loans were approved out of 14,427 applications. An allocation of RM 100 million (1997) and RM 203.5 million (1998) were granted. An annual loan of RM 6,500 was given to students of public institutions of higher learning and RM 12,000 to students of private institutions of higher learning for their academic financial support.

9. DEGREE CONFERRING AGENCIES

Graduates of Malaysian universities are conferred their degrees by their own universities. Graduates of private institutions of higher learning involved in the "twinning programmes" will be awarded degrees from the overseas institutions of higher learning. Graduates of polytechnics and teacher training institutes are conferred their diplomas by the relevant institutions. No other agency in Malaysia is given the responsibility to confer degrees or diplomas other than institutions recognized by the Ministry of Education and the Constitution.

10. ASSESSMENT OF HIGHER EDUCATION INSTITUTIONS

To initialize a new course programme, universities have to gain approval from the Ministry of Education. Presently, the public institutions of higher learning in Malaysia do not have to undergo any form of accreditation from any accreditation agency or body. The academic quality of each university is taken care of by the Senate of the university, chaired by the Vice Chancellor. Curriculum design and development is generally carried out and determined at the faculty/school level and subject to approval of the Senate. However, faculties/schools in the field of engineering, architecture, medical and survey, will initiate their own curriculum development or audit, under the supervision of a recognized professional body or members of professional institution as advisers.

11. INTERNATIONAL RECOGNITION OF DEGREES

Being a member of the United Nations and a Commonwealth country, Malaysia participates in the Commonwealth Convention and the UNESCO Convention regarding the equivalence of university qualifications in the related countries. Recognition of foreign degrees rests with the Public Services Department in collaboration with the Ministry of Education and other related public agencies; recognition of professional awards and merit rests with the appropriate professional organization existing in Malaysia. Academic awards of diploma, undergraduate and postgraduate degrees awarded by the public institutions of higher learning in Malaysia are accepted by most Commonwealth, European and American institutions of higher learning as an equivalent entry qualification to the institutions.

REFERENCES

- Abdullah Sanusi Ahmad.(1996). *Challenges in Managing Higher Education Institutions in the Context of the New Environment*. Seminar on Management of Faculties in Higher Education Institutions, Universiti Malaya.
- Berita Publishing Sdn Bhd. (1995). *Information Malaysia 1995 Year*. Berita Distributors Sdn Bhd. Kuala Lumpur.
- Challenger Concept (M) Sdn. Bhd. (1994). *Education Guide Malaysia (2nd. Ed.)*. Challenger Concept (M) Sdn. Bhd., Kuala Lumpur.
- Challenger Concept Sdn. Bhd. 1996. *Education Guide Malaysia-Vision 2020 (3rd. Ed)*. Challenger Concept (M) Sdn Bhd, Kuala Lumpur.
- Institut Teknologi Mara. (1995). *Prospektus 1995-1996*. Public Relations Unit.
- International Islamic University Malaysia. (1996). *Postgraduate Prospectus 1996/97*. Office of Admissions.
- International Islamic University Malaysia. (1996). *Undergraduate Prospectus 1996*. Office of Admissions.
- Johari Mat.1996. *Towards Implementating the New Education Legislations*. Seminar on Management of Faculties in Higher Education Institutions. Universiti Malaya.

- Universiti Kebangsaan Malaysia. (1995). *Kalendar 1995/96*. Pejabat Perhubungan Awam.
- Universiti Malaya (1995). *Kalendar Universiti Malaya*. Bahagian Perhubungan Awam.
- Universiti Malaysia Sabah. (1995). *Prospektus Pra Siswazah 1995*. Universiti Malaysia Sabah
- Universiti Malaysia Sabah. (1995). *Postgraduate Programme Prospectus 1995*. Universiti Malaysia Sabah
- Universiti Malaysia Sarawak. (1996). *Prospektus Pra Siswazah 1996/7*. Bahagian Hal Ehwal Akademik.
- Universiti Pertanian Malaysia. (1996). *Buku Panduan Universiti Pertanian Malaysia*. Universiti Pertanian Malaysia,
- Universiti Teknologi Malaysia. (1995). *Calender 95/96*. Universiti Teknologi Malaysia.
- Universiti Teknologi Malaysia.(1996). *Prospektus Sesi 1996/97*. Universiti Teknologi Malaysia.
- Population Distribution and Basic Demographic Characteristics Report*. 29 Jul. 2003. Department of Statistics, Malaysia. 5 Aug. 2003. <<http://www.statistics.gov.my/English/framesetPressdemo.htm>>.
- Education and Social Characteristics of the Population*. 29 Jul. 2003. Department of Statistics, Malaysia. 5 Aug. 2003. <<http://www.statistics.gov.my/English/pressedu.htm>>.
- Data Penting - Keys Statistics, Malaysia*. 1 Aug. 2003. Department of Statistics, Malaysia. 5 Aug. 2003. <<http://www.statistics.gov.my/English/framesetNSDP.htm>>.
- Gross Domestic Product (GDP)*. 4 Apr. 2003. Federation of Malaysian Manufacturers. 5 Aug. 2003. <http://www.fmm.org.my/p_ne_it.asp?NewsID=490&ThemeID=272&From-Theme>
- Skilled Manpower to Propel the K-Economy*. 5 Aug. 2003. <http://www.mier.org.my/mierscope/shankaran13_4_2002.pdf>.
- Enrolmen Sekolah Rendah Mengikut Jantina dan Negeri, Malaysia, 2000*. 6 Aug. 2003. <[http://www.moh.gov.my/PnD/INDICATORS%20FOR%20MONITORING%20EVALUATION%20F%20STRATEGY%20FOR%20HEALTH%20FOR%20\(2000\)%5CSocial%20Socio-Economic%20Development%20Indicators%20.pdf](http://www.moh.gov.my/PnD/INDICATORS%20FOR%20MONITORING%20EVALUATION%20F%20STRATEGY%20FOR%20HEALTH%20FOR%20(2000)%5CSocial%20Socio-Economic%20Development%20Indicators%20.pdf)>
- Politeknik-politeknik Kementerian Pendidikan Malaysia*. Politeknik Kota, Melaka. 6 Aug. 2003. <http://www.polimelaka.edu.my/poli_add.html>.
- Bahagian Pendidikan Guru - Komitmen Menyeluruh Menjamin Kecemerlangan*. 16 Jul. 2003. Bahagian Pendidikan Guru. 6 Aug. 2003. <<http://www2.moe.gov.my/~bpg/>>.
- Majlis Pendidikan Tinggi Negara (MPTN)*. Jabatan Pendidikan Tinggi. 6 Aug. 2003. <<http://www2.moe.gov.my/~jpt/english/jpt.htm>>.

Kenyataan Akhbar YB Tan Sri Dato' Seri Musa Mohamad. 7 Aug 2003. <<http://www.moe.gov.my/keratanBI.asp>>.

Portal Pendidikan. Utusan Melayu (M) Berhad. 8 Aug. 2003. <<http://www.tutor.com.my/tutor/infoipt/index.asp?sec=UiTM>>.

University College of Science and Technology Malaysia. 14 Jul. 2003. University College of Science and Technology Malaysia (KUSTEM). 8 Aug. 2003. <<http://www.kustem.edu.my/english/index.php>>.

Kolej Universiti Islam Malaysia. 8 Aug. 2003. <<http://www.kuim.edu.my/>>.

Kolej Universiti Teknologi Tun Hussein Onn. 8 Aug. 2003. <http://www.kuittho.edu.my/kuittho/index_e.htm>.

Kolej Universiti Kejuruteraan Utara Malaysia. 8 Aug. 2003. <<http://www.kukum.edu.my/>>.

Kolej Universiti Teknikal Kebangsaan Malaysia. 8 Aug. 2003. <<http://www.kutkm.edu.my/>>.

Kolej Universiti Kejuruteraan & Teknologi Malaysia. 8 Aug. 2003. <<http://www.kuktem.edu.my/>>.

1. COUNTRY PROFILE

New Zealand lies in the south-west Pacific Ocean. Its area of 270,500 square kilometres comprises two main islands, the North Island and the South Island, and a number of smaller islands. The country is mountainous, particularly in the South Island, and is more than 1,600 kilometres long, while only 450 kilometres wide at its widest part, giving it a long coastline for its area. The population of 4 million is concentrated in the North Island, particularly in the vicinity of Auckland, the largest Polynesian city in the world. About 80 per cent of the population is New Zealand European, while about 15 per cent is New Zealand Māori. Other groups represented are mainly of Pacific Island, Indian and Chinese origin. The official languages are English and Māori.

A member of the Commonwealth, New Zealand is an independent state with a parliamentary government. The sovereign head of the Commonwealth is Queen Elizabeth II, who is represented in New Zealand by a Governor-General.

The country's economy has developed from one in which trade was almost exclusively focused on agricultural exports to the United Kingdom in return for consumer goods, to one with a global outlook in which primary produce, manufactured products and human skills are exported to diverse destinations. In the 1980s an intensive period of 'restructuring' began, and in the 1990s inflation was reduced to very low levels after having reached high levels in the late 1980s. For the year ended December 2002, the economy grew by 4.4%, and the unemployment rate of 4.9% was the lowest in fifteen years. Student enrolments in tertiary education have increased by 16.6% in the five years since 1997.

About 18 per cent of the government's expenditure is directed towards education.

2. NATIONAL EDUCATION SYSTEM

Primary and secondary education is free, compulsory and secular in nature. By law children must start formal schooling at age six, but in practice nearly all children start on their fifth birthday and have six years of primary schooling, followed by two years of intermediate. Five years of secondary education are offered. Education is compulsory until the age of 16.

In 2001, average teacher:student classroom ratios ranged from 1:18 to 1:22 across the various year levels and school types. The New Zealand school year usually runs from the end of January to mid-December, and is divided into four terms. Both single sex and co-educational schooling options are available and state (public) schools are secular.

In New Zealand the term “early childhood education” refers to education and care for young children and infants before they begin school. A wide range of early childhood services is available. English is the language of most services, however, some provide an environment in which children learn in Māori (kohanga reo), Pacific Island or other languages from birth to six years of age.

Primary education starts at Year 1 and continues until Year 8, with Years 7 and 8 offered at either a primary or a separate intermediate school. Secondary education covers Years 9 to 13, (during which students are generally aged 13 to 17). Most secondary students in New Zealand attend Government-funded schools, which are known variously as secondary schools, high schools, colleges or area schools. Students are classified according to the number of years of education they have received, replacing the old nomenclature of Form (secondary and intermediate education) and Junior or Standard (primary education).

Most schools are English language medium, but some schools teach in the Māori medium. Kura Kaupapa Māori are schools in which the principal language of instruction is Māori and education is based on Māori culture and values. Most Kura Kaupapa Māori cater for students from Years 1 to 8 and a few (Wharekura) cater for students up to Year 13.

The current system of secondary qualifications is being replaced and by 2004 will consist of the National Certificate of Educational Achievement (NCEA), which may be gained at level 1 in Year 11, level 2 in Year 12, and levels 3 and 4 in Year 13. The NCEA has a mixture of internal and external assessment.

The Curriculum Framework for schools, developed by the Ministry of Education, outlines the desirable attitudes and values which should form part of every student’s learning. A curriculum stock take is currently underway. In the schools the curriculum is based on the seven essential learning areas of: language and languages, mathematics, science, technology, social sciences, the arts, and health and physical well-being.

The essential learning areas are broad, recognisable categories of knowledge and understanding. They constitute a balanced curriculum within which the essential skills, attitudes, and values are developed. The essential skills include: communication, numeracy, information, problem solving, self-management and competitive, social and cooperative, physical, and work and study.

At the tertiary level New Zealand has 8 universities, 20 polytechnics, 4 colleges of education (teacher training establishments), and there are also 3 wānanga (centres of higher learning based on Māori language and customs). All of these tertiary institutions were established and are funded by the government. There are also in excess of 900 registered private or government training establishments offering secondary and/or tertiary level courses. The private sector organisations have only been established since 1990 and most are small compared with the public sector institutions. A new category of public institution, the specialist college, was created in 2003, but no specialist colleges yet exist.

Although universities are the main providers of degrees, all other tertiary institutions are capable of becoming accredited to provide degree level qualifications up to doctorate level. The division between secondary and tertiary education has also become less distinct, as the number of pathways to further education and training have increased. It is not uncommon for secondary school pupils to be taking part-time courses of study or training at institutions that are accredited to offer tertiary qualifications. Work-based industry training is also increasing.

The Education Act of 1989 replaced the former Department of Education with the Ministry of Education, which is responsible for developing and implementing educational policy from early childhood to the tertiary level. Universities, polytechnics, colleges of education and wānanga are now governed by their own individual councils, while schools are administered by boards of trustees elected by their local communities.

The Tertiary Education Commission (TEC), established in 2003, is responsible for funding all post-compulsory education and training offered by universities, polytechnics, colleges of education, wānanga, private training establishments, foundation education agencies, industry training organisations and adult and community education providers. To comply with the government's accountability requirements, all tertiary organisations must submit their charters and profiles to TEC for approval and their accounts are subject to government audit.

The New Zealand Qualifications Authority (the Qualifications Authority), established in 1990, has several functions, including:

- to oversee the setting of standards for qualifications, both secondary and tertiary, and to monitor and regularly review those standards;
- to develop a framework of national qualifications;
- to establish policies and criteria for the approval of courses and for the accreditation of providers to offer them;
- to administer national examinations at secondary and tertiary levels; and
- to ensure New Zealand qualifications are recognised overseas, and overseas qualifications are recognised in New Zealand.

The Education Review Office, also established in 1990, is responsible for reviewing the achievement of educational objectives in schools, and early childhood centres, including private schools, kura kaupapa Māori (Māori language immersion schools), special schools and ngā kōhanga reo (Māori language early childhood groups), and providing evaluative reports thereon.

The Qualifications Authority was established with a key function of having an overview of qualifications in compulsory and post-compulsory education and training. This function was exercised initially through the development of the National Qualifications Framework (NQF) comprised of national certificates and diplomas and their component unit standards. This framework has now been expanded through the development of the New Zealand Register of Quality Assured Qualifications (the "Register"). All qualifications approved by a recognised approval and accreditation body will be included on the Register.

The New Zealand Register of Quality Assured Qualifications has ten levels and is comprised of qualifications that are registered in accordance with an agreed set of title definitions. Each qualification must have a level, and be worth at least 40 credits (where 1 credit is equal to a notional '10 hours' of learning). The following information will be held in the databases supporting the Register and will be publicly available:

- the title of the qualification;
- the level at which the qualification is registered;
- the outcome statement attached to the qualification;
- the credit requirements of the qualification;
- the subject classification; and
- qualification developer/provider details.

New Zealand Register of Quality Assured Qualifications: Titles and Levels

Level	Title
10	Doctorates
9	Master's
8	Postgraduate Diplomas, Bachelor's with Honours
7	Bachelor's, Graduate Diplomas
6	Graduate Certificates
5	Diploma
4	Certificates
3	
2	
1	

3. HIGHER EDUCATION SYSTEM

As described earlier, the tertiary institutions comprise the universities, polytechnics and colleges of education, together with wānanga and government or private training establishments.

Offering degrees is no longer restricted to the universities. The passage of the Education Amendment Act in 1990 provided the machinery for any education provider to apply to offer degrees. However, every degree must be approved by a quality assurance body and the provider must be accredited to offer it. In the case of the universities the quality assurance body is the Committee on University Academic Programmes of the New Zealand Vice-Chancellors' Committee, while all other providers must seek approval and accreditation from the New Zealand Qualifications Authority. The exception here is that from July 2003 polytechnic degrees will be approved and accredited by the Association of Polytechnics in New Zealand (APNZ) through the New Zealand Polytechnic Programmes Committee (NZPPC). By mid-2003 nearly 300 degrees have been approved for providers other than the universities. These are mainly bachelor's and masters degrees but a few doctorates have also been approved.

One institution, The Open Polytechnic of New Zealand, offers its qualifications, which include degrees, entirely by correspondence or other distance education methods. Massey University has, since its establishment in 1964 as an autonomous institution, developed an extramural programme to serve the whole country. Today; there are 21,000 extramural students out of a total Massey roll of nearly 37,000. Other providers, availing themselves of rapid developments in telecommunications technology, are also becoming involved in distance education.

All the providers offering degrees have administrative autonomy. The state-funded institutions are grouped under three coordinating bodies, the New Zealand Vice-Chancellors' Committee (NZVCC) for universities, the APNZ for polytechnics, and the Association of Colleges of Education of New Zealand (ACENZ) for Colleges of Education. Private training establishments that offer degree programmes may belong to one of a number of groups representing private providers. These bodies act as advocates for the institutions, give policy advice, coordinate

certain activities such as the award of scholarships, and promote relationships between institutions both nationally and internationally.

Every state-funded institution is governed by a council, which is charged with appointing the chief executive and, among other things, with ensuring the institution strives to attain the highest standards of excellence in education and research and maximises educational opportunities for the community which it serves. The council is empowered by law “to provide courses of study or training, admit students ... and grant awards.” In order to offer a course of study the institution should first apply to the appropriate quality assurance body. Once approval has been granted the university, polytechnic, college of education, specialist college, wānanga or private training establishment may award the qualification to which the course of study leads. In the case of a national qualification the award may be made by either the provider or the Qualifications Authority.

The use of the terms national and New Zealand is restricted to approved qualifications developed by qualifications developers who can demonstrate that their development process has involved and has had the support of the appropriate nationally recognised bodies related to the subject title and major content of the qualification. The term national is restricted to qualifications based on unit or achievement standards – or qualifications that have components for which there is automatically transferable credit. The term New Zealand is available for non unit standard based qualifications of national standing. National and New Zealand qualifications are available for any provider to offer so long as they are appropriately quality assured in line with the qualification developer’s and quality assurance body’s requirements.

4. CHARACTERISTICS OF DEGREES AND DIPLOMAS

The following qualifications are available in New Zealand:

- Certificates may be used in a wide range of contexts across levels 1 through 7, and are often used to prepare candidates for both employment and further education and training. A certificate is the smallest size of qualification that can be registered.
- Diplomas often prepare learners for self-directed application of skills and knowledge. These qualifications recognise capacity for initiative and judgement across a broad range of educational and vocational areas, in technical, professional, and/or management roles and often build on prior qualifications or experience.
- A bachelor’s degree is a systematic and coherent introduction to the knowledge, ideas, principles, concepts, chief research methods and problem-solving techniques of a recognised major subject (or subjects, in the case of a double degree or a double major). It requires meeting specified requirements, as set down in the relevant degree regulations, and involves at least one sequential study programme in which content is progressively developed to the point where a candidate is prepared for post’graduate study and supervised research. It prepares a candidate for advanced study as well as directed research and scholarship in the major subject(s) of the degree. A bachelor’s degree may be awarded with honours to recognise advanced or distinguished study in advance of a level 7 bachelors degree.

- A graduate certificate is designed primarily as a vehicle for graduates to pursue further study at an undergraduate level. The graduate certificate can be designed as a bridging programme for candidates developing educational, professional or vocational knowledge in a new discipline, professional or subject area and/or as a broadening or deepening of skills or knowledge already gained in an undergraduate programme.
- A graduate diploma is designed as a vehicle for graduates to pursue further study at an undergraduate level. The programme can be designed to broaden knowledge and skills in a familiar subject or discipline or develop knowledge in a new area.
- A post-graduate certificate involves credits from a specified subject and, where appropriate, its cognate areas. It serves as a qualification recognising continuing professional development in the same area as the candidate's original degree. A candidate will normally have completed all requirements of a bachelors degree or, in special circumstances, a bachelors degree with honours. The postgraduate certificate is designed to extend and deepen a candidate's knowledge and skills through formal instruction and directed inquiry.
- A postgraduate diploma is designed to extend and deepen a candidate's knowledge and skills by building on attainment in the principal subject(s) of the qualifying degree. It provides a candidate with a systematic and coherent survey of current thinking and research in a particular body of knowledge and may include instruction in the relevant research methodologies.

A master's degree is normally designed to build on the principal subject(s) of the qualifying degree. Alternatively, a master's degree may build on relevant knowledge and skills derived from occupational experience, as in the Master of Business Administration (M.B.A). Different discipline areas have different traditions. Thus national and international comparisons are relevant for a masters degree in a particular area. Typically they require students to demonstrate mastery of theoretically sophisticated subject matter; to evaluate critically the findings and discussions in the literature; to research, analyse and argue from evidence; to apply knowledge to new situations; and to engage in rigorous intellectual analysis, criticism and problem-solving. A masters degree programme contains a significant element of supervised research. The results of that research are normally embodied in a thesis, dissertation or substantial research paper, but in some cases are incorporated in a series of papers. Creative work may also contribute to the research output. The research should demonstrate a capacity in the candidate for independent thinking.

The doctorate is a research degree that is at a significantly higher level and of significantly higher status than a masteral. It is normally the culmination of a structured sequence of instruction at educational institutions which begin at the bachelor level and reaches a stage beyond the masters level when the student becomes an increasingly independent scholar and makes a substantial and original contribution to knowledge. For the Ph.D./D.Phil. and the named doctorate this development takes place under the guidance of recognised experts in the field of study and under circumstances which allow the student access to appropriate research resources. The doctorate is awarded on the basis of an original and substantial contribution to knowledge as judged by independent experts applying contemporary international standards. The hallmark will be the candidate's capacity for substantial independent research or creative activity as attested (for the Ph.D./D.Phil. and the named doctorate) by his/her educational institution and/or as demonstrated by submitted work.

With the exception of the honorary doctorate the major component of all doctorates is original research. The body of work that leads to the award of a doctorate will be one of the following:

- a thesis (the Ph.D./D.Phil.);
- creative work in the visual or performing arts (the Ph.D./D.Phil.);
- a thesis or equivalent creative work in combination with coursework (the named doctorate);
- a thesis in combination with a creative work in the visual or performing arts (the named doctorate);
- published work (the higher doctorate); and
- exceptional contribution to society (the honorary doctorate).

A degree title must relate to the principal disciplinary emphasis of the qualification and, through its qualifier where appropriate, be concise, accurate and informative.

A degree title should:

- have wide national or international acceptability, or
- be necessary for national or international recognition of that qualification, or
- be a requirement of a professional body that has a formal role in the approval of the qualification.

Bachelor of Arts	B.A.
Bachelor of Arts in Communications	B.A. (Comms.)
Bachelor of Science	B.Sc.
Bachelor of Science (Technology)	B.Sc.(Tech.)
Bachelor of Health Science	B.H.Sc
Bachelor of Health Science in Nursing	B.H.Sc.(Nurs.)
Bachelor of Technology	B.Tech.
Bachelor of Business	B.Bus.
Bachelor of Business Studies	B.B.S.
Bachelor of Commerce	B.Com
Bachelor of Commerce and Management	B.C.M.

In the area of the traditional professional degrees the well-established nomenclature prevails on the whole, for example:

Bachelor of Architecture	B.Arch.
Bachelor of Laws	L.L.B
Bachelor of Medicine and Bachelor of Surgery	M.B.Ch.B
Bachelor of Engineering	B.E.

The certificate awarded on completion of a qualification generally contains the following information:

- the name of the awarding institution or body;
- the name of the student;
- the name of the qualification being awarded; also the class of honours, or awards of 'merit' or 'distinction' (if applicable);

- the field of study (but not in all cases); and
- the date of the award.

Unit standards and NQF qualifications are classified according to the following categories:

- Field
- Sub-field
- Domain

A field is the broadest classification category. It covers a general area such as engineering and technology. A sub-field is a smaller category within a field. The sub-field name is often used for qualifications. There may be several sub-fields within each field. A domain is a smaller classification grouping within a sub-field. Normally a domain includes 10-30 unit standards. Domain names can also be used in the naming of qualifications. In unit standard documents, the domain is listed in capital letters before the title, for example HEATING AND VENTILATION (domain): Integrate hot water heating systems components (title).

5. STUDY PROGRAMMES

A person who holds a bachelors degree may be permitted to enrol for the postgraduate diploma or the masters degree. A person with a bachelors degree with honours may be permitted to enrol for a masters degree or a doctoral degree. The graduate certificate or graduate diploma may provide an entry point to postgraduate study. A postgraduate certificate provides the basis for further postgraduate study. A postgraduate diploma may be awarded with distinction. It prepares a candidate for independent research and scholarship in the principal subject of the diploma. A person who holds a postgraduate diploma may be enrolled for a masters degree or a doctoral degree. A person who holds the masters degree may be admitted to a programme of advanced study and original research leading to a doctoral degree.

Study for most certificates and diplomas can be completed within one year.

The basic bachelor's degree (e.g. Bachelor of Arts, Bachelor of Science) in New Zealand is three years in length. In most cases a 4th year may be taken to enable a student to qualify for an award of honours (first class; second class-first division; second class-second division; or third class honours). In some disciplines the degree takes longer than three years to complete. These are generally professional disciplines such as engineering, law or pharmacy (four years), architecture, dentistry or veterinary science (five years), or medicine (six years).

The master's degree may be two years of study after a bachelor's degree or one year of study after a bachelor's degree with honours. It may consist of a thesis only, papers and a thesis, or in some cases (e.g. Master of Business Administration) papers only.

The doctor's degree may be undertaken after a master's degree or a bachelor's with first or second class honours. While at least two years must be spent in conducting original research and writing a thesis, students typically take three or more years to complete the degree.

There is no common unit of currency to describe the structure of degrees. Each provider determines their own structure. Thus degrees may be made up of subjects, courses, papers, modules, units, credits or points. The three years of a bachelor's degree are sometimes referred to

as stage 1, stage 2 and stage 3 respectively, but because of the numbering systems often used the terms 100-level, 200-level and 300-level (or 1000-level, 2000-level, 3000-level) are just as appropriate.

Practical experience may be necessary for degrees of an applied nature, e.g. agriculture, dentistry, engineering, forestry science, horticulture, medical laboratory science, nursing, social work, veterinary science, and others. The requirements vary enormously and no summary can be attempted.

Evaluation of students' work is carried out in the main by the teachers of their courses. At higher levels, for example in the third year of a degree or later, some outside moderation may occur. For master's and doctor's degrees it is customary for at least one examiner on the panel to be from another institution, generally one outside New Zealand.

Grading systems may vary from provider to provider, but a common arrangement is the 9-point scale of passes: A+, A, A-, B+, B, B-, C+, C, C-, with D and E as failing grades. The percentages represented by these grades also vary. Generally speaking, the following will apply:

A+		
A	75 % and over	Pass with distinction
A-		
B+		
B	60-74 %	Pass with merit
B-		
C+		
C	50-59 %	Pass
C-		
D	40-49 %	Fail
E	Below 40 %	Bad Fail

Also used by some providers:

P	Pass
F	Fail

Some providers calculate a grade point average, but this is uncommon.

Unit standards are reported as either Achieved or Not Achieved. The NCEA provides a detailed report of a student's achievements. For each Achievement standard a student can achieve one of the following four grades:

NA	Not Achieved
A	Achieved
M	Achieved with Merit
E	Achieved with Excellence

6. ADMISSION REQUIREMENTS

Admission to universities by domestic students in New Zealand has traditionally been quite open. There is no entrance examination as such, but to qualify for admission students are required to reach a certain standard in what is currently known as the New Zealand University Entrance, Bursaries and Scholarships (NZUEBS) examination, taken in Year 13. The required standard is prescribed by the Qualifications Authority and the NZVCC and in 2003 stands at three C grades. (Grade C = a range of marks between 46% and 55%). Alternately, university entrance can be achieved with at least 13 credits in approved unit standards in each of three different approved subjects at level 3 or above on the NQF, or by obtaining a combination of credits in approved subjects (at least 13 credits on the NQF at level 3 or above) and grades C or better in each of three NZUEBS subjects. In addition students must be awarded Higher School Certificate, which attests to the completion of five years of secondary schooling.

From 2004, a person shall be qualified for entrance to a university in New Zealand if he/she has obtained:

- a minimum of 42 credits at level 3 or higher on the National Qualifications Framework, including a minimum of 14 credits at level 3 or higher in each of two subjects from an approved subject list, with a further 14 credits at level 3 or higher taken from no more than two additional domains on the National Qualifications Framework or approved subjects; including
- a minimum of 14 credits at level 1 or higher in Mathematics or Pangarau on the National Qualifications Framework; and
- a minimum of 8 credits at level 2 or higher in English or Te Reo Māori; 4 credits must be in Reading and 4 credits must be in Writing. The literacy credits will be selected from a schedule of approved achievement standards and unit standards.

Once a New Zealand resident reaches the age of 20, however, admission is automatic, although not necessarily to courses of the student's choice. Gaining admission to a university, by whatever means, may not gain a student admission to particular courses. In some cases, where the number of applicants is greater than the number of places that can be made available, the universities apply additional selection criteria, mainly of an academic nature. For example, a significantly better performance in NZUEBS than three Cs may be required, or a particular level of previous learning, such as in languages, may be sought.

Students who gain total marks in the range 250-299 in NZUEBS are said to have earned a New Zealand 'B' Bursary, while those who gain 300 marks or more have earned a New Zealand 'A' Bursary. Those in the latter category are likely to be admitted to all the courses of their choice in most disciplines, although in those of engineering, medicine and veterinary science total marks well above 300 may be required. In 2004 NZUEBS will be replaced by NCEA level 3, and a separate Scholarship qualification at level 4.

International students can gain entrance to University through **admission ad eundem statum (at entrance level)**. This is the means whereby students, who have completed secondary education either in a country outside New Zealand or through following a programme offered in New Zealand, that cannot be defined in terms of the common entrance standard, may have their

studies recognized by the universities as equivalent to the common entrance standard. An application is based on certified and translated copies of each academic certificate or transcript. It is very important that photocopies are certified as true copies of the original by a recognizable authority. International students must also provide evidence of ability in the English language.

The academic year in New Zealand runs from March to November, although some institutions also offer a 'summer school' from December to February. Students are generally required to signify their enrolment intentions for the following year to the providers concerned no later than the previous December, and in some cases, e.g. music performance, earlier than this. International students should make enquiries about admission no later than 1 September to enable their applications to be dealt with in time for the next academic year. NZUEBS examinations, the main determinant of eligibility to enter universities (to the end of 2004), are held in November, with results appearing in mid-January.

Provision is made for students to enter university from Year 12 instead of Year 13. In such a case a student must be at least 16 years of age, have achieved at least one good grade in Sixth Form Certificate or a minimum of 14 credits in an approved subject at Level 2 towards NCEA, and be recommended by a sponsor, usually the school principal. Small numbers of students enter the universities every year under this provision.

7. DEGREE CONFERRING AGENCIES

Degrees are conferred by the providers which offer them.

8. ASSESSMENT OF HIGHER EDUCATION INSTITUTIONS

Tertiary education providers are under continual review. The individual universities set themselves programmes to permit thorough reviews to be carried out of all their academic and administrative operations on a five to seven-year cycle. In addition they are subject to academic audit by the New Zealand Universities Academic Audit Unit (NZUAAU), which examines their mechanisms for quality assurance and for monitoring and enhancing the academic standards which are necessary to achieve their aims and objectives. Furthermore their professional programmes, e.g. architecture, law, medicine, are regularly reviewed by the professional bodies responsible for the registration of practitioners.

NZQA requires other providers offering approved degrees to be reviewed and re-accredited on a one to three-year cycle. The review process is similar for all accredited providers, whether state-funded or private, and generally requires the provider to compile a portfolio of information on the programme under review and to host a visit from a panel of up to five members, who will interview staff and students where appropriate. Subsequently the panel will issue a report on its findings, which may include recommendations for improvements to be implemented by the provider.

9. DEGREES AND PROFESSIONAL COMPETENCE

In several professions a graduate must undertake a period of probation, or even further examinations, before being regarded as eligible to practise. Eligibility to practise is customarily achieved through registration by an official body such as a national council or registration board.

In the medical field a year or more of “internship” is common. For example, graduates in medicine and pharmacy must complete 12 months of clinical practical experience before registration. A psychology graduate may be required to complete up to two years of experience before being registered to practise as a psychologist.

Teacher trainees are granted provisional registration upon completion of their diplomas and may apply for full registration after two years of experience. These provisions will be extended to early childhood education by 2012.

Accountancy graduates must obtain three years of practical experience before being granted full registration, and further skills training including two professional examinations, must be undertaken. Engineering graduates have to meet a competency standard, which includes a time component of two to three and a half years post-graduate experience.

Other professions, for example physiotherapists and medical laboratory technologists, have similar requirements of a period of probation followed by registration. Dentists, lawyers and veterinary surgeons are the exceptions in that graduates are entitled to be registered as soon as they have completed their degrees. Dentists, however, are encouraged to undertake a professional development programme during their first year of practice and many of them do so. Registration is required before dental, law, and veterinary graduates can practise.

In all cases registration must be renewed annually.

10. INTERNATIONAL RECOGNITION OF DEGREES

New Zealand degrees are generally accepted and recognised internationally. Graduates of New Zealand universities are accepted directly into the leading graduate schools in North America and the United Kingdom. Those with professional degrees such as medicine, dentistry, engineering, law and accountancy are eligible to become registered practitioners in most countries. New Zealand has a growing number of international students who will return to their own countries to work on completion of their degrees.

The New Zealand universities are participants in the UMAP (University Mobility in Asia and the Pacific) programme, established in 1991. The general objective of UMAP is to achieve, by extended and enhanced co-operation between higher education institutions, a better understanding within countries of the region of its cultural, economic and social systems through increased mobility of students and staff in higher education. The quality of higher education in the region should thereby be improved.

In 1998 New Zealand and Australia made a Ministerial declaration of confidence on the Mutual Recognition of Vocational Education and Training Qualifications between Australia and New Zealand. This complements the 1996 Trans-Tasman Mutual Recognition Arrangement, which entitles any person who is registered to practise an occupation in either Australia or New Zealand to practise an equivalent occupation in the other country, without the need to undergo further testing or examination.

10. INTERNATIONAL RECOGNITION OF DEGREES

New Zealand Qualifications Authority
P O Box 160
Wellington
Website <http://www.nzqa.govt.nz>

New Zealand Vice-Chancellors' Committee
P O Box 11-915
Wellington
Website <http://www.nzvcc.ac.nz>

Association of Polytechnics in New Zealand
P O Box 10-344
Wellington
Website <http://www.apnz.ac.nz>

New Zealand Teachers Council
P O Box 5326
Wellington
Website <http://www.trb.govt.nz>

Association of Colleges of Education in New Zealand
PO Box 10 298
Wellington
Website <http://www.acenz.ac.nz>

REFERENCES

- Education Act 1989 and its amendments*, New Zealand Government, Wellington, 1989 et seq.
- Ministry of Education, *The New Zealand Education System: An Overview*, 2003.
- Ministry of Education, *The New Zealand Curriculum Framework*, http://www.tki.org.nz/r/governance/nzcf/index_e.php, 2002.
- Ministry of Education, *New Zealand's Tertiary Education Sector Report - Profile and Trends 2001*, 2002.
- New Zealand Qualifications Authority, *New Zealand Qualifications for International Students*, <http://www.nzqa.govt.nz/for-learners/nzstudy/index.html>, 2003.
- New Zealand Qualifications Authority, *New Zealand Register of Quality Assured Qualifications*, <http://www.nzqa.govt.nz/qualifications/register/regpolicy-may03.pdf>, May 2003.
- New Zealand Vice-Chancellors' Committee, *Degree Qualifications in New Zealand: A User's Guide*, <http://www.nzvcc.ac.nz/cuap/useguid02/contents.html>, 2002.
- Statistics New Zealand, *Profile of New Zealand 2000*, 2000.

1. COUNTRY PROFILE

The Philippines is an archipelago composed of 7,107 islands with a land area of 115,737 square miles spanning 1,143 miles from north to south and 688 miles from east to west. It is situated in the eastern rim of the Asiatic Mediterranean between the Pacific and Indian Oceans and between Australia and mainland Asia. It stretches from China to the north and the Indonesian archipelago to the south. Its northernmost islands are approximately 240 kilometres south of Taiwan, and the southernmost islands are approximately 24 kilometres from the coast of Borneo.

The Philippines is divided into three major island groups: Luzon (the northern-most part), Visayas (the center), and Mindanao (the southern-most part). It is geographically and culturally divided into 16 regions and 79 provinces.

As of 2003, the country's population is about 82 million. The Filipinos are basically of Malay stock with a sprinkling of Chinese, American and Arab blood. They are recognizable by distinct traits and dialects. The national language is Filipino and at least 111 dialects are spoken. However, Filipinos have a flair for the English language. English is extensively used in school, business, and government and private transactions.

Although Asia is dominated by Buddhism and Islam, the Philippines is predominantly Christian. About 85 per cent are Roman Catholics, seven per cent are followers of Islam, and the rest belong to other types of religions.

Over the past years, there had been some structural reforms in the Philippine economy - a more effective monetary environment was established, the financial sector was deregulated, banking reforms were instituted, and critical segments of the economy were opened up such as foreign exchange, banking and finance, foreign and domestic investments, telecommunications, insurance, inter-island shipping and transportation. These have led to higher incomes, more jobs in industry and stable prices. By the 21st century, the Philippines hopes to become one of Asia's most dynamic economies.

2. NATIONAL EDUCATION SYSTEM

The education system in the country includes formal and non-formal education. Compared to other Asian countries, the Philippine education system differs in a number of ways. The Philippine education system closely resembles the American system of formal education while other Asian countries are influenced by the English, French or Dutch system. Basic education in the Philippines is only ten years as against twelve in other countries. The country is using a bilingual medium of instruction. Certain subjects are taught in English and the rest in the national language which is Filipino.

2.1 Formal education

The formal education is a sequential progression of academic schooling at three levels, namely, elementary, secondary and tertiary education. The structure of the formal system of education is illustrated in Figure 1.

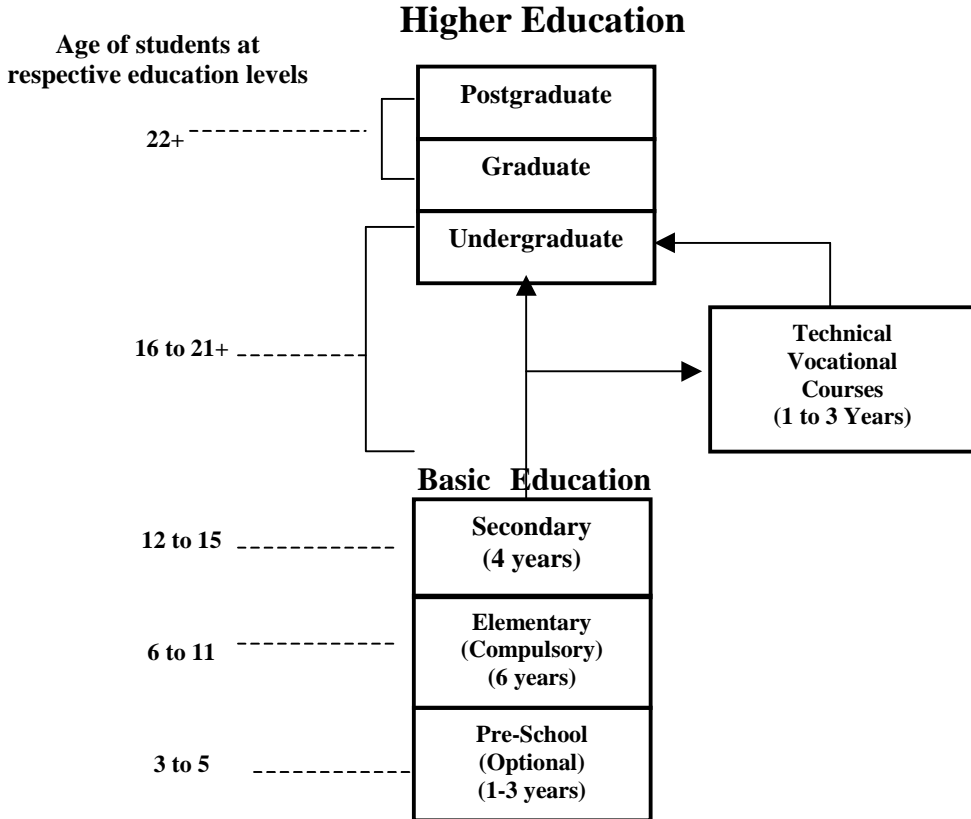

Figure 1. The Philippine Education System

Basic education

Basic education consists of elementary and secondary levels. The first level, elementary education, is compulsory consisting of six grades (Grades 1- 6) for pupils aged six to eleven years. There is optional pre-school education which consists of nursery, kindergarten and preparatory courses. At age three or four, a pupil may enter the pre-school, and at six years old proceeds to grade one. The second level, secondary education, corresponds to four years of high school for students aged twelve to fifteen years, the prerequisite of which is completion of elementary education.

Tertiary education

The third level is tertiary education where a student enters at age sixteen. It covers all post-secondary courses, from one-year to three-year vocational-technical courses to four-year degree

and professional programmes, including graduate education (master's and doctoral levels) and postgraduate education. In essence, tertiary education covers both postsecondary vocational-technical courses and higher education programmes.

As of School Year 2002-2003, there are 53,662 schools in all levels (Table 1). Of the 41,288 elementary schools, 89 per cent is public. In the secondary level, of the 7,890 schools, almost 59 per cent is public. And of the 1,380 higher education institutions, 12 per cent is public. Enrolment statistics for all levels are shown in Annex 1, Table 2.

2.2 Non-formal education

Non-formal education is an organized learning activity intended for a particular clientele, especially the out-of-school youths or adult illiterates who cannot avail themselves of formal education. Courses are skills-oriented and range from 6 to 10 months or more.

3. HIGHER EDUCATION SYSTEM

Higher education lies at the apex of the education system. The vision and mission of higher education in the Philippines including the strategic directions to be pursued are embodied in a comprehensive document of the Commission on Higher Education (CHED) entitled "Long-Term Higher Education Development Plan (LTTHEDP), 2001-2010."

Vision

The higher education system of the Philippines is a key player in the education and integral formation of professionally competent, service-oriented, principled, and productive citizens. Through its tri-fold function of teaching, research, and extension services, it becomes a prime-mover of the nation's socio-economic growth and sustainable development.

Mission

Guided by this vision, higher education institutions that comprise the system shall: offer programmes and services that meet the demands of an industrializing economy within the context of sustainable development and a culture of peace, as well as the challenges of a diverse and globalized society; nurture an academic environment that fosters integrated learning, creative and critical thinking, appreciation of cultural diversity and national identity, and inculcates moral values; conduct research to support instruction, create new knowledge and enhance the quality of life in society; and undertake extension programs and services that facilitate the transfer of technology, foster leadership and promote self-reliance among the less privileged in Philippine society.

Strategic directions

For the first five years, the higher education system shall focus on systemic reform and strengthening in order to enhance its capability to respond to national demands and international challenges. During the second half of the planning decade, the thrust shall be on the operationalization of structures, policies and programmes to ensure the system's performance as knowledge center in selected disciplines.

3.1 Types of higher education institutions

There are two types of higher education institutions (HEIs) in the country, namely, public and private. The system is unique characterized by a predominantly big private sector. Public HEIs

are established through legislation while private institutions are established either through Act No. 2706 (the Private Education Law) as amended, or Batas Pambansa Blg. 232, and incorporated as educational institution under Act No. 1459 (the Corporation Law as amended).

As of School Year 2002-2003, the country had a total of 1,380 higher education institutions, 166 (or 12.03 per cent) are public and 1,214 (or 87.97 per cent) are private. Public institutions are broken down into: 107 state universities and colleges (SUCs), 3 CHED-supervised institutions (CSIs), 40 local colleges and universities (LCUs), and 16 other government schools (OGS). On the other hand, of the 1,214 private higher education institutions (PHEIs), 305 are sectarian and 909 are non-sectarian.

State universities and colleges (SUCs) are established by law and financially supported by the national government. They are governed by their own charter with the board of trustees/regents as the policy-making body.

The CHED-supervised institutions (CSIs) also established by law are under the supervision of the CHED. Their annual budget comes from the national government. In 1998, originally there were 102 CSIs. As of 2003, there are only three (3) CSIs remaining, the rest were integrated as a campus of the nearest SUC in their respective region.

Local colleges and universities (LCUs) previously called community colleges are those operated, supported and maintained by local government units. These institutions are established by virtue of an Ordinance passed by their respective local government units.

Furthermore, there are **other government schools (OGS)** such as vocational-technical institutions offering bachelor's degree programmes and special schools offering undergraduate and/or graduate degrees and advanced training such as military and police academies which are supervised and regulated by the Department of National Defense and Philippine National Police.

Private higher education institutions (PHEIs), on the other hand, are established in accordance with law, duly authorized to operate higher education programs by CHED. They are owned by private groups or individuals organized into corporations. Their operations are principally supported through tuition and other student fees. They are classified either as sectarian or non-sectarian colleges and universities. Sectarian institutions are usually non-stock, non-profit institutions, owned and operated by religious orders. Non-sectarian institutions are owned by corporations which are not affiliated to any religious organizations, majority of them are stock, a few are non-stock non-profit corporations, and a number are foundations.

3.2 Co-ordination of the higher education system

For many decades, the administration, supervision and regulation of higher education was vested in only one agency of government, the Department of Education, Culture and Sports (DECS) through its Bureau of Higher Education (BHE). However, with the so many concerns, DECS was able to focus more on basic education and higher education was neglected for the most part. Hence, to put proper attention on the improvement of higher education, two laws were passed by Congress of the Philippines in 1994: 1) Republic Act No. 7722 creating the ***Commission on Higher Education (CHED)***, otherwise known as the Higher Education Act of 1994; and 2) Republic Act No. 7796 creating the ***Technical Education and Skills Development Authority (TESDA)***. Recently, another law was passed in Congress, Republic Act No. 9155, changing the DECS into ***Department of Education (DepEd)*** removing the components of culture and sports under its jurisdiction and providing for the new governance of basic education.

As a result of the trifocalization of education, the DepEd concentrates only in the administration, supervision and regulation of basic education. TESDA, an agency attached to the Department of Labor, oversees the post-secondary technical and vocational education including skills orientation, training and development of out-of-school youths and community adults. The CHED, a department-level agency attached to the Office of the President of the Philippines, oversees the higher education sector and focuses its attention on system governance and policy guidance over public and private HEIs. As mandated, the CHED monitors and evaluates the programs of HEIs, formulates and implements development plans, policies and standards, and undertakes developmental programs and projects on higher education.

3.3 Institutional governance

Higher education institutions establish and maintain their own internal organization. The framework of their organization is generally divided into two areas, namely: policy formulation and policy implementation. The HEIs have their respective Governing Boards which are primarily responsible in the formulation and approval of all policies, rules and standards in the institutions. The implementation of policies and management of the institutional operations are vested in the administration headed by the President appointed by the Board of Regents/Trustees.

The SUC's autonomy is assured by their individual charters. They are authorized to open curricula and institutional programs, and award their own degrees. On June 6, 1997, a landmark legislation was made enacting into law Republic Act No. 8292 otherwise known as the "Higher Education Modernization Act of 1997." This Act provides among others for the uniform composition and powers of the governing boards of all SUCs with the Chairman of CHED as the Chair of the governing boards (previously chaired by the DECS Secretary). With this set-up, in effect the SUCs are placed under the supervision of CHED. It enables the CHED to exert influence or provide proper guidance in upgrading the quality of the academic programs as well as improving the internal operations of the SUCs.

In the case of CSIs and LCUs, the CHED monitors their performance in terms of compliance to existing policies, rules and standards. These institutions have to secure authority from CHED if they want to open additional new courses or programmes not specified in the legal basis or Ordinance which created them.

The private HEIs, on the other hand, experience some degree of freedom in their internal operations when their programs are Level III accredited. They are fully deregulated in terms of administrative matters and financial aspect particularly in setting tuition and other fees. They have curricular autonomy and can initiate reforms in their program offerings without securing approval from CHED. Otherwise, they have to apply for permit from CHED to open a course, and they have to apply for recognition of their programs in order to be allowed to graduate their students. Recognition of programs is granted if the institutions have fully complied with the minimum requirements prescribed by CHED. Certificates, diplomas or degrees are awarded to students only if all academic requirements have satisfactorily been completed by the students. After verification of the academic records of the graduating students as certified by the School Registrars, the CHED issues "Special Order" which is indicated in the student's transcript of records .

4. CHARACTERISTICS OF DEGREES AND DIPLOMAS

4.1 *Types of degrees and diplomas*

The titles, descriptions and abbreviations of the degrees and diplomas being granted by the higher education institutions are as follows:

Undergraduate Level

- Certificate, Diploma and Associate Programmes

These titles are awarded upon completion of programmes requiring three months to three years of study. These are non-degree technical or vocational education programmes leading to skills proficiency which are mostly terminal in nature. Some one-, two-, and three-year courses are components of ladder-type bachelor's degree programmes.

- Bachelor's Degree (Bachelor [B.], Bachelor of Arts [A.B.], Bachelor of Science [B.S.])

These titles are awarded upon completion of a minimum of four years of study on a semestral basis. Some programs however, require more than four years of study. If on trimester basis, the program may be completed in less than four years.

Graduate Level

- (a) Certificate and Diploma Programs - These titles are awarded upon completion of one or two years of study beyond the bachelor's degree which are not equivalent to a master's degree.
- (b) Master's Degree (Master [M.], Master of Arts [M.A.], Master of Science [M.S.], Master of Professional Studies [M.P.S.]) - These titles normally requires completion of four semesters of course work, about two years in duration. In general, a master's programme require a thesis, but there are some programmes which are non-thesis.
- (c) Doctoral Degrees (Doctor [D.], Doctor of Philosophy [Ph.D.]) - These titles are awarded upon completion of two or three years of study beyond the master's degree. A dissertation is a requirement for graduation in the programme.

4.2 *Disciplines or fields of study*

Undergraduate and graduate degrees and diplomas in the Philippines are classified under the following ten (9) clusters of disciplines: (1) Agriculture Education, (2) Business and Management Education, (3) Engineering, Technology and Architecture, (4) Health Profession Education (5) Humanities, Social Sciences and Communication, (6) Legal and Criminology Education, (7) Information Technology, (8) Maritime Education, (9) Science and Mathematics and (10) Teacher Education. The following are the fields or disciplines included in each cluster.

Agriculture Education

- Agriculture and allied fields, agricultural engineering, fisheries, forestry and veterinary medicine.

Business and Management

- Commerce, business management/administration, business economics, accountancy, banking and finance, marketing, office management, secretarial administration, customs administration.

Engineering and Architecture

- Civil engineering, mechanical engineering, electrical engineering, chemical engineering, electronics and communication engineering, industrial engineering, metallurgical engineering, geodetic engineering, aeronautical engineering, aerospace engineering, aircraft maintenance engineering, computer engineering, mining engineering, sanitary engineering.
- Architecture, industrial design.

Health Profession

- Anatomy, anesthesiology, biochemistry, clinical pathology, legal medicine, microbiology, neurology, obstetrics, ophthalmology, parasitology, pathology, pediatrics, pharmacology and therapeutics, physical medicine and rehabilitation, physiology, community medicine, health, psychiatry, radiology, surgery and orthopedics.
- Nursing, midwifery, physical and occupational therapy, nutrition and dietetics, optometry, medical technology, dentistry.

Humanities, Social Sciences and Communication

- Literature, philosophy, arts and music.
- History, political science, economics, psychology, sociology, anthropology.
- Broadcasting, film, journalism, advertising, public relations, communications research, cross-cultural communication.

Legal and Criminology Education

- Laws, jurisprudence
- Criminology

Information Technology

- Computer science, information technology, information management, information science, computer data processing management, computer technology.

Maritime Education

- Naval architecture and marine engineering, marine transportation, marine engineering, basic merchant marine course.

Science and Mathematics

- Natural sciences and applied sciences such as biology, botany, microbiology, physiology, zoology, chemistry, biochemistry, physics, geology, astronomy, meteorology, oceanography, metallurgy, pharmacology.
- Mathematics, applied mathematics, statistics, applied statistics.

Teacher Education

- Elementary education, secondary education, agricultural education, fisheries education, industrial education.

4.3 Information contained in the document

The diploma or certificate being granted after completion of a degree contains information on the name of the recipient of the degree, the title awarded and the field of study, the name of the college or university conferring the diploma with its authorized signatories which are usually the President/Head and the Dean and/or Registrar.

5. STUDY PROGRAMMES**5.1 Number of credits and sequence and duration of study**

For undergraduate programmes, the minimum curricular requirement is a combination of the minimum required general education subjects, core subjects, professional subjects or major subjects including electives. The minimum required total number of credit units for four-year bachelor's degree programmes ranges from 120 to about 190 units depending on the fields of study. There are two options for the minimum required general education subjects: Option A consisting of 63 units is meant for degree programmes in the humanities, social sciences and communication. Option B which consists of 51 units is intended for fields other than the humanities, social sciences and communication.

Subject	Number of Units	
	Option A	Option B
English	9	6
Filipino	9	6
Literature	6	-
Mathematics	6	6
Natural Sciences	6	6
Science Elective	3	3
Humanities	6	9 (including Literature, Art, Philosophy)
Social Sciences	12	12
Mandated Subjects	6	3
Total	63	51

For graduate programmes, the minimum number of credit units is as follows:

- Master's degree programme = 30-36 units (24 to 30 units of course work, inclusive of required common core subjects of about 12 units, plus additional 6 units of thesis)
- Doctoral degree programme = 45-60 units (inclusive of required common core subjects of 12 units or more and 12 units of dissertation)

It should be noted that the number of units over and above the minimum requirement for a specific degree programme varies from one institution to another. There are no specific regulations as to sequence of the subjects in a particular degree programme. For purposes of definition of terms, the following are adopted:

- (a) *Degree* is the title conferred upon a student following the successful completion of a program of study.
- (b) *Degree programme* is the collection of all courses in a discipline or field of study, which is also referred to as an academic program.
- (c) *Course* which is also known as *subject* is a discrete component of a degree programme which is identified by a course name and its coverage is defined by a course description and outline or syllabus.
- (d) *Unit* is a standard of measure of the credits awarded upon completion of a course or subject. It is based on the hours of academic instruction. A one-unit lecture course in both undergraduate and graduate levels consists of 17 hours of instruction. A one-unit laboratory course in both undergraduate and graduate levels consists of 51 hours of instruction.

In general, the duration of study in terms of number of years of the different degree programmes offered in the Philippines is as follows:

Degree Programs	Number of years
Undergraduate:	
Science and Mathematics	4
Humanities, Social Sciences and Communication	4
Information Technology	4
Health-Related	4-5
Medicine (4 years baccalaureate plus 4 years proper)	8
Veterinary Medicine	6
Dentistry (2 years pre-dental plus 4 years proper)	6
Engineering and Architecture	5
Marine Engineering	4
Business and Management	4
Agriculture Education	4
Teacher Education	4
Law (4 years baccalaureate plus 4 years proper)	8
Criminology	4
Graduate:	
Master's degree programme	2
Doctoral degree programme	3

The above duration of study is applicable for institutions which adopt semester term. In the case of those which adopt trimester or quarter term, the number of years varies, normally shorter in duration.

5.2 *Work experience as part of the curriculum*

In almost all fields of study, work experience as part of the curriculum is required. For instance, in fields like business and management, teacher education, engineering, maritime, agriculture, medicine and other health-related programmes, students have to undergo some exposures on the job which can be in the form of practicum, on-the-job training or occupational internship, community work or extension activities. The duration varies depending on the degree programme, different programs have different total number of hours required. In some programmes, the practicum or on-the-job training ranges from one whole semester to about one year or more.

It can be noted further that education and the acquisition of skills can also take place in the workplace and beyond the confines of the classroom. There is a programme known as Expanded Tertiary Education Equivalency and Accreditation Programme (ETEEAP) which is considered as an integral part of the higher education system in the Philippines. The CHED, through the deputized higher education institutions, is implementing a system of academic equivalency and validation of the knowledge and experience derived by individuals from relevant work experiences and high-level, non-formal and informal training toward the awarding of an appropriate academic degree.

5.3 *Grading and Evaluation System*

Every higher education institution adopts a certain grading and evaluation system. Normally there are oral and written examinations to evaluate the student's performance in a particular subject. Aside from these, student's interest, attitude and attendance as well as submission of class requirements such as term papers, projects, etc. are generally included in computing the final grades. Majority of the higher education institutions use letters, grade point averages or percentages in rating the student's performance. Below is the grading system commonly used in the undergraduate and graduate programs:

Letter	Meaning	Grade Point	Percentage
A	Excellent	1.00 1.25	97 - 100 94 - 96
A-	Very good	1.50 1.75	91 - 93 88 - 90
B+	Good/above average	2.00 2.25	85 - 87 82 - 84
B	Satisfactory/average	2.50 2.75	79 - 81 76 - 78
B-	Passed	3.00	75
C	Conditional Failure	4.00	
F	Failure	5.00	Below 75
W	Withdrawn		
UW	Unauthorized Withdrawal		
INC	Incomplete		
NC	No Credit		
DRP	Dropped		

6. ADMISSION REQUIREMENTS

Each higher education institution has its own admission policy. Some institutions are very selective in admitting students, they require entrance examination and medical examination as well as interviews. There are many institutions which adopt open admission but selective retention. As part of the academic freedom, higher education institutions have the right to determine whom to admit or accept into their programmes. As a general rule, eligible for admission to the bachelor's degree programmes are graduates of secondary education. There are however special admission requirements for dentistry, medicine and law programmes.

In dentistry, the applicant-student who wants to continue in the dentistry proper should get a Certificate of Admission (COA) from the institutions he wants to enroll. He must be a graduate of a pre-dentistry course which should include 15 units of English, 3 units of Mathematics, 10 units of Chemistry, 5 units of Physics, 10 units of Zoology, 5 units of Botany, 12 units of Social Science, 9 units of Filipino and 3 units of Personal and Community Hygiene subjects.

In medicine, a student who has finished a four-year bachelor's degree and wants to pursue medicine as a second degree should pass the National Medical Admission Test (NMAT) and secure a Certificate of Eligibility to Medicine (CEM) from the institution he wants to enroll. The applicant must have earned 15 units of Biology, 10 units of Chemistry, 9 units of Mathematics, 5 units of Physics and 12 units of Social Science subjects.

In the case of law degree, a student who wants to be admitted should have a four-year bachelor's degree and secure a Certificate of Eligibility for Law (CEL) from the institution he wants to enroll. The applicant must have earned 18 units of English, 6 units of Mathematics and 18 units of Social Science subjects.

For graduate programs, in general, admission to the master's degree programme requires entrants to have a general weighted average of at least 85 or "B" or "2" in the undergraduate course. On the other hand, a weighted average of at least 1.75 in the master's degree is a requirement for admission to the doctoral degree programme.

7. DEGREE CONFERRING AGENCIES

The individual higher education institution confers the degrees. State universities and colleges are authorized to confer degrees by virtue of their respective charter. Similarly, the CHED-supervised institutions and local universities and colleges, classified as public institutions, are allowed to confer degrees. The private higher education institutions are authorized to confer degrees if their programme offerings have government recognition issued by CHED (previously by DECS).

8. ASSESSMENT OF HIGHER EDUCATION INSTITUTIONS

The CHED is mandated to set and enforce minimum standards for programmes and institutions of higher learning and at the same time, monitor and evaluate their performance for appropriate incentives as well as imposition of sanctions such as diminution or withdrawal of subsidy, recommendation on the downgrading or withdrawal of accreditation, programme termination or school closure. The CHED is also tasked to set standards, policies and guidelines for the creation of new institutions as well as conversion or elevation of schools to a college or university status.

There are two types of accreditation in the Philippines, namely, government accreditation and private accreditation. Government accreditation is done by CHED which involves the process of issuance of government authorization to offer programs to the private HEIs in the form of permit or recognition. The SUCs do not secure government authority from CHED in offering programs while the CSIs and LCUs in some instances secure authority when they do not have legal basis for the programs to be offered. In the case of the private HEIs, permit or recognition is granted to them upon compliance to the minimum requirements prescribed by CHED for the various programmes. For this purpose, the CHED has Regional Offices in the different regions of the country assisted by the Regional Quality Assessment Teams (RQATs) in the different disciplines which are tasked to evaluate the extent of compliance of the HEIs to the minimum standards.

On the other hand, private accreditation which is voluntary in nature, pertains to the accreditation being done by the private accrediting bodies. Accreditation standards are beyond the minimum requirements prescribed by CHED for the various programmes. CHED encourages accreditation by giving HEIs incentives and greater autonomy. Because of the recognition and benefits which CHED has been extending to HEIs with accredited programmes, accreditation is now viewed as a means of promoting educational excellence through self-regulation and peer evaluation.

The Federation of Accrediting Agencies of the Philippines (FAAP) is the umbrella organization which is authorized to certify the accredited status of programs granted by the different accrediting agencies, namely: the Association of Christian Schools and Colleges Accrediting Agency, Inc. (ACSC-AAI), the Philippine Accrediting Association of Schools, Colleges and Universities (PAASCU), the Philippine Association of Colleges and Universities Commission on Accreditation (PACU-COA), and the Accrediting Agency of Chartered Colleges and Universities of the Philippines (AACUP).

The major steps in the accreditation process are as follows: (1) institutional self-survey or self-evaluation; (2) preliminary visit (four to six months after the start of self-survey); (3) formal survey visit (a minimum of six months after preliminary visit); and (4) decision by governing board of accrediting agency.

The levels of accreditation are as follows:

- Level I applicant status: for programmes which have undergone a preliminary survey visit and are certified by the FAAP as being capable of acquiring an accredited status within two years;
- Level II accredited status: for programmes which have been granted accredited status by any of the member agencies of the FAAP and whose status is certified by the latter;
- Level III accredited status: for programmes which have at least been re-accredited and have met additional requirements based on criteria/guidelines set by FAAP; and
- Level IV accredited status: institutions which have distinguished themselves in a broad area of academic disciplines and enjoy prestige and authority comparable to that of international universities.

The benefits for the different accreditation levels are as follows:

- Level I - partial administrative deregulation.
- Level II – full administrative deregulation, financial deregulation in terms of setting tuition and other fees, partial curricular autonomy, authority to graduate students without prior approval of CHED and without need for Special Orders, priority funding assistance, priority for government subsidy for faculty development, right to use on its publications or advertisements the word “ACCREDITED”, and limited visitation/inspection and/or supervision by CHED.
- Level III – all the benefits for Level II and full curricular deregulation.
- Level IV – all the benefits for Levels II and III, award of grants/subsidies from the CHED’s Higher Education Development Fund (HEDF), and grant of charter or full autonomy.

It can be noted that as part of the government initiatives to improve quality of higher education in the country, the CHED identifies centres of excellence and centres of development in the various disciplines to HEIs which have consistently exhibited qualities indicating excellence in instruction, research and extension, of which one of the criteria is level III accreditation of the programme. The CHED is also granting autonomy and deregulated status to deserving private colleges and universities on the basis of their distinctions as centers of excellence or centres of development or institutions with level III accreditation in their programmes, outstanding performance of graduates in licensure examinations, long tradition of integrity and untarnished reputation.

9. DEGREES AND PROFESSIONAL COMPETENCE

The government regulates the practice of profession in the Philippines. Graduates in the following fields are entitled to practice their profession if they pass the licensure or board examinations being given by the Professional Regulation Commission (PRC):

- | | |
|--|---|
| • Accountancy | • Mechanical Engineering |
| • Aeronautical Engineering | • Medical Technology |
| • Agricultural Engineering | • Medicine |
| • Architecture | • Metallurgical Engineering |
| • Chemical Engineering | • Midwifery |
| • Chemistry | • Mining Engineering |
| • Civil Engineering | • Naval Architecture and Marine Engineering |
| • Criminology | |
| • Customs Broker | • Nursing |
| • Dentistry | • Nutrition and Dietetics |
| • Electrical Engineering | • Optometry |
| • Electronics & Communications Engineering | • Pharmacy |
| • Environmental Planning | • Physical Therapy |
| • Forestry | • Occupational Therapy |
| • Geodetic Engineering | • Radiologic Technology |
| | • Sanitary Engineering |

- Geology
- Library Science
- Marine Deck
- Marine Engineering
- Master Plumbing
- Social Work
- Veterinary Medicine
- Teacher Education
- Interior Design
- Landscape Architecture

In the case of Law, the Supreme Court administers the bar examination.

10. INTERNATIONAL RECOGNITION OF DEGREES

The Philippines is a signatory of the UNESCO Regional Convention on the Recognition of Studies, Diplomas and Degrees in Higher Education in Asia and the Pacific which was held in Bangkok, Thailand on December 12-16, 1983. Recently, the Philippine government has ratified this agreement. During the Third Regular Session of the 12th Congress on September 3, 2003, the Senate of the Philippines approved the ratification of the said agreement.

ANNEX 1

Table 1. Distribution of Schools in the Philippines, School Year 2002-2003

Level	Number of Schools		Total
	Public	Private	
Elementary	36,759	4,529	41,288
Secondary	4,629	3,261	7,890
Technical-vocational	-	-	3,104
Higher Education	166	1,214	1,380
Total	41,554*	9,004*	53,662

Data Source: DepEd, TESDA, and CHED

*Data for technical-vocational are not included.

Table 2. Enrolment Statistics in the Philippines, SY 2002-2003

Level	Enrolment		Total
	Public	Private	
Elementary	12,500,450	929,178	13,429,628
Secondary	4,793,511	1,284,340	6,077,851
Technical-vocational	-	-	543,255
Higher Education**	808,321	1,657,735	2,466,056
Total	18,102,282*	3,871,253*	22,516,790

Data Source: DepEd, TESDA, and CHED

*Data for technical-vocational are not included.

**Available data are for SY 2001-2002

REFERENCES

- Biglete, Amelia A. "Major Higher Education Reforms in the Philippines." A Country Report in: *Recent Reform and Perspectives in Higher Education*. Tokyo, Japan: National Institute for Educational Research (NIER), 1998.
- Biglete, Amelia A. *Philippine Higher Education: Realities and Reform*. CIDE Occasional Papers Series: Higher Education, CIDE Contributions No. 6. eds. John N. Hawkins and Val D. Rust. Los Angeles, California: Center for International and Development Education (CIDE) and UCLA Graduate School of Education and Information Studies (GSEIS). July 2003.
- Biglete, Amelia A., Lilia S. Garcia, Alicia S. Bustos and Roderick C. Salazar, Jr. "Strategies for Quality and Excellence," in *The Reform and Development of Higher Education in the Philippines*, ed. M.D. Valisno. Manila, Philippines: Philippine National Commission for UNESCO Education Committee, 2000.
- Bureau of Higher Education (BHE). *Higher Education in the Philippines: In Capsule*. Pasig City, Philippines, 1992.
- Commission on Higher Education (CHED). *Long-Term Higher Education Development Plan, 1996-2005*. Pasig City, Philippines, 1995.
- Commission on Higher Education (CHED). *Philippine Higher Education: A Brief Guide*. Pasig City, Philippines, 1998. (Preliminary Report)
- Commission on Higher Education (CHED). *Development Indicators on Higher Education (1990-1999)*. Pasig City, Philippines, 1998.
- Commission on Higher Education (CHED). *Medium-Term Higher Education Development and Investment Plan (MTHEDIP) 2001-2004*. Pasig City, Philippines, 2001.
- Commission on Higher Education (CHED). *Long-Term Higher Education Development Plan, 2001-2010*. Pasig City Philippines, 2001.
- CHED Order No. 31, s. 1995. *Policies on Voluntary Accreditation in Aid of Quality and Excellence in Higher Education*.
- CHED Memorandum Order No. 46, s. 1996. *Policy of Progressive Deregulation Vis-a-vis Higher Education Institutions (HEIs)*.
- CHED Memorandum Order No. 59, s. 1996. *New General Education Curriculum (GEC)*.
- CHED Memorandum No. 4, s. 1997. *Guidelines for Implementation of CHED Memorandum Order No. 59, s. 1996 – New General Education Curriculum (GEC)*.
- CHED Memorandum Order No. 36, s. 1998. *Policies and Standards on Graduate Education*.
- CHED Memorandum Order No. 32, s. 2001. *Grant of Autonomy and Deregulated status to Selected Higher Educations with Benefits Accruing Thereto*.

CHED Special Order No. 42, s. 2003. *Guidelines for the Formulation of Policies and Standards of Academic Programs.*

Department of Education, Culture and Sports (DECS). *Education 2000: The First Two Year.* May 1994.

DECS Order No. 3, s. 1993. *Providing for New Minimum Requirements in the General Education and Other Components of Initial Bachelor's Level Courses of Study.*

DECS Order No. 12, s. 1994. *Revised and Simplified Rules and Standards for Graduate Education.*

Executive Order No. 330 (May 10, 1996). *Adopting the Expanded Tertiary Education Equivalency and Accreditation Program as an Integral Part of the Educational System and Designating the Commission on Higher Education as the Authority Responsible for Its Implementation.*

Republic Act No. 7722. *An Act Creating the Commission on Higher Education, Appropriating Funds Therefor and for Other Purposes.* May 18, 1994.

Republic Act No. No. 7796. *Technical Education and Skills Development Act of 1994.*

Republic Act No. 8292. *An Act Providing for the Uniform Composition and Powers of the Governing Boards, the Manner of Appointment and Term of Office of the President of Chartered State Universities and Colleges, and for Other Purposes,* July 22, 1996.

Republic Act No. 9155. *Governance of Basic Education Act of 2001.*

Task Force on Higher Education. *Philippine Higher Education in the 21st Century: Strategies for Excellence and Equity.* Pasig City, Philippines: Commission on Higher Education, 1995.

Valisno, Mona D. *Private Higher Education in the Philippines.* Manila, Philippines: UNESCO Higher Education Policy Series No. 2 - 2001.

RUSSIAN FEDERATION

*Yuri Akimov
Victor Chistokhvalov*

1. COUNTRY PROFILE

The Russian Federation area is 17,075,400 square kilometres with a population of 146 million. It consists of 89 subjects of the Federation, among them 31 autonomous territories. Russia has 1,095 cities, 1,963 towns and 24,456 villages. It is a multinational country inhabited by more than 150 nationalities.

The State language is Russian, which uses the Cyrillic alphabet. An autonomous republic may have a local language as the second official language.

2. NATIONAL EDUCATION SYSTEM

The national education system includes a complex of successive education programmes (syllabi) and state educational standards of different levels and orientations, a network of education institutions of different organizational and legal forms, education administrative bodies as well as institutions and enterprises reporting to them. The following levels of education and corresponding education institutions are:

- pre-school education - kindergartens;
- general education (primary, basic, secondary/complete) - schools, "gimnasiya"s;
- vocational education/ training-vocational schools "professionalnoe uchilishche"s),
- vocational schools with secondary general education ("professionalny litsei"s); and
- higher education:
 - (a) non-university level ("srednee professionalnoe obrazovanie" -intermediate professional education) - "tekhnikum"s / "uchilishche"s, colleges
 - (b) university level - universities, academies,
- institutes - postgraduate professional education/doctoral programmes - those among education institutions and research establishments that are entrusted with corresponding rights (See section 3.2);
- further professional education - specialized divisions of higher education institutions or specialized establishments.

The Federal (central) administrative body of pre-school, general and vocational education is the Ministry of Education of the Russian Federation. For the higher education of all levels the Federal (central) administrative body is the State Committee for Higher Education of the Russian Federation.

2.1 Pre-school training and learning

Pre-school learning is the first link in the chain of the general system of education which now consists of a network of 50,000 pre-school institutions that house 4,246,300 children. Since 1992 this network has dwindled by 37,900 and the number of children by 2,989,700. The cutback in the number of institutions and children has been registered practically all over Russia. Thus, in the academic year 2002-03 these institutions were attended by 52.6% of children in the age group 1-6 years while in the preceding 2001-2002 the figure was 53.9%. The cutback was due to economic reasons as well as the decrease in birth rate, living standards of families resulting to their refusal to enrol their children.

In 1995, Russia introduced a diversified system of pre-school institution according to types and categories. More nursery schools with one or several development priorities have come into being; the same concerns nursery schools of a compensating type; schools of childcare and health protection; schools of a combined type; and child development centres. Over the last five years, a significant increase has been registered in the number of compensating-type pre-school institutions. Besides, new flexible varieties of corrective tutoring help children under school age learn and develop through short-term attendance and home learning, integration of children requiring special care into a normal child community.

Provision is made for the continuity of the pre-school and elementary school education. Correspondingly, the network of educational institutions to this effect is permanently growing. There are now about 4,000 institutions of this type with an enrolment 290,500 children.

The emergence of new educational programmes and teaching technologies gave rise to the problem of quality control over pre-school education, which is necessary to protect children from unprofessional and incompetent influences. Such a control measure was provided by the State Pre-school Education Standards.

One of the major factors having an impact on the quality of pre-school learning is the teaching staff. Nursery schools today are staffed by 622,000 teachers, 98.6 % of whom are specially educated (in 1992, 92.5%). Educational standards of the staff is markedly growing. Over the last year only the number of teachers with complete or incomplete higher education increased by 1.4 % (and 10.9 % compared with 1992).

2.2 General education

In the academic year 2002-2003 the Russian Federation had 65,700 general education institutions of various kinds attended by 18.44 million learner; of them the number of lyceums = 2,191 (1,440,400 learners); schools with advanced teaching = 6,204 (1,284,100 learners).

The analysis of the dynamics of the general education development over the last years reveals that it has not undergone any substantial changes. There is, though, a trend in the increase of the number of elementary and secondary (complete) schools in cities along with the simultaneous decrease of basic schools. In the rural districts, elementary schools decreased by 577 (4%) and

basic schools by 100 (0.9%), as compared with academic year 2000-2001 whereas the number of secondary schools, both in urban and rural areas, is growing (total growth = 66 schools, which makes 0.3%). The process of reduction was owing mostly to closing elementary and basic schools (in 2001-2002 a total of 919 elementary and 279 basic schools, and in 2000- 2001, 605 elementary schools and 188 basic schools were closed). There are several reasons for this such as the closure of dilapidated old school buildings; fall of birth rate since 1992, etc. Further closing of elementary and basic schools might adversely affect the infrastructure in rural areas.

The growth of urban elementary schools and simultaneous fall of basic schools might be indicative of a possible tendency of refusal from the orientation of urban schools to establishing large-scale general education institutions. Over the last two years, the number of urban secondary schools with an enrolment exceeding 1,600 decreased by 131; while elementary schools with an enrolment of 61-100 increased by 52 and those of 120-180 by 56 institutions.

A new positive trend is the reduction of schools working two and three shifts. Their total number went down by 802.

In the academic year 2001-2002, the number of senior school learners went up. The 10th formers (2,922,000) accounted for 66.3 % of basic school graduates compared with 52%-54 % over the years of compulsory secondary education.

Russia has a total of 662 non-government general education institutions. Their share in the overall system of secondary education, though, is still rather small and accounts for a mere 0.8% (0.2% attendance) of the total number of general education institutions. Non-government institutions of general education absorb 65,940 school children with 16,000 teaching staff. Less elementary schools and more basic schools, accredited by the State, is also a trend to be taken into account.

One of the priorities in the system of general secondary education is the protection and support of educational interests of nationalities and ethnic groups living in Russia. There are now 82 native languages studied across the country. Learning at the general education institutions is performed in 35 native languages. There are 3,554 schools, attended by 244,000, delivering education in the native (non-Russian) languages.

The number of teaching staff in the system of the general secondary education over the last two years has been going up. Estimates show that while 2001 ratio between learners and rural teacher was a little higher than 9:1 (9.23), the same figure in 2002 averaged 9.17. Urban figures were 14.51 and 14.35, respectively.

The staff of teachers, though its female share has a tendency of going down from 85.1% to 84.9%, remains largely female-dominated. Particularly important is the age of the staff. About 12.5% of the urban teachers are of retiring age, whereas in rural areas it is 7.5%.

Elementary professional (vocational) education

The elementary vocational educational is one the most important resources of training skilled labourers and specialists as well as retraining released and unemployed population. Two-thirds of the people employed now in various branches of the Russian economy were trained in the elementary vocational schools. Today Russia has 3,858 elementary vocational training schools with an attendance of 1,648,700 people, including 3,530 day schools with an attendance of 1,607,400. Vocational training schools and lyceums realize two mayor functions:

- social, by offering a high-quality elementary vocational training giving the learners adequate opportunities for entering adult life;
- economical, by planned reproduction of skilled labour for enterprises and organizations of all Russia's branches of economy.

Elementary vocational training institutions in Russia (dayshift learning) provide for 110 learners per 10,000.

This system best of all realizes the principle of the accessible and free-of-charge learning, which is extremely important, since 75% of learners come from low-income and broken families. The system of the elementary vocational training employs some 160,000 teaching staff, including 90,300 (56.4%) having higher education; 56,000 (35.6%) with secondary vocational training and 12,800 (8.0%) with general secondary education.

Some 39.6% of the elementary vocational training institutions are financed from the budgets of RF Subjects.

In 2002 these institutions admitted 806,300 students, including 693,500 in the day schools and lyceums.

One important aspect in streamlining elementary vocational training is working out efficient mechanisms of translating the social call to the system of education. One of them is undoubtedly the forecast of the demand for skilled labour and specialists. It is to be taken into account that boys and girls who enter vocational schools and lyceums at the age of 14-15, must study, and, consequently, tentative figures of admission should be based on the highest possible involvement of the potential 9th form general education graduates. Over the last three years teaching capacity of elementary vocational training schools was balanced with the number of young people willing to obtain education at this level.

In 2002, vocational institutions turned out 737,400 skilled labour, including 627,400 from day schools. Graduates were in high demand from employers. The figures covering the whole of the Russian Federation reveal that only 14.6% of graduates were not employed for lack of vacancies.

Realizing the principle of the continuity, many vocational school graduates pursue further learning at the secondary and higher professional education institutions (9.9% of the total from day professional schools and lyceums).

Quantitative and qualitative assessment of the elementary vocational training network allows to conclude that this kind of education is now accessible to the majority of the Russian youth on a broad free-of-charge and non-competitive basis.

The content of the elementary vocational training is in the process of further improvement. Up to now authorities have worked out and approved State educational standards involving 91 skills of the elementary vocational training system. A comprehensive methodical provision of the state educational standards is now available as a database for all concerned. Recommendations on the expertise and assessment of curricula and syllabi for the registered skills are ready for implementation. A study is underway of setting up a system of forming principal and supplementary general education programmes that help learners prepare for the absorption of

the principal programmes in the higher and secondary professional education. Researchers also discuss fundamentals of integrating education institutions of different levels into broader education amalgamations. Criteria have been formulated for the assessment of the professional competence of the teaching and administrative staff in the elementary vocational training schools and their conformity to the appropriate qualification requirements.

Secondary professional (vocational) education

Twenty-two per cent of Russia's population today have secondary vocational education, which is 1.5 times higher than that of the percentage of people who have higher professional education. As of October 1, 2002, Russia had 2,931 state and municipal secondary vocational training institutions and subdivisions of higher educational institutions implementing curricula of the secondary vocational training. The number of students studying at the state and municipal secondary special schools reached 2,445,000 people; admission, 862,000; and graduation 568,000 people. The non-governmental sector of the secondary vocational training accounted for 152 institutions with an attendance of 25,000 students.

Since 1995 the dynamics of training in the state and municipal vocational institutions shows a sustained rise in the admission and number of students, and since 1996, the number of graduates over the last five years admission has increased by 179,000 people or 27%, total attendance by 388,000 (2%), graduation by 95,000 or 20%.

Growth rates in the vocational training in 2002 were considerably higher than the average annual growth over the last five years, and reached 78,000 people in admission (10%) and 164,000 students in attendance (8%). Budgetary admissions to the secondary vocational training schools in 2002 rose by 16,000 people (3%) as compared with 2000.

The educational process in the state and municipal technical schools involves over 180,000 teachers of whom 6,400 are Ph.D. and D.Sc. holders, that accounts for 3.5% of the total teaching staff (in 1996, 2.6%).

The advance of the secondary vocational training today is marked by rising both the demand for and number of students. Secondary technical schools are more or less evenly distributed over the Subjects of the RF and function not only in large cities but in other populated areas which is particularly important to meet regional academic and staff needs.

The profile of the secondary vocational training is also undergoing significant changes. Thus, the percentage of admission to the Economics and Humanities went down from 12.6% of the total in 1998 to 12% in 2002 whereas technical and agricultural skills went down (from 52.95 to 36.7% and from 121.6% to 9.4%, respectively).

The number of secondary vocational training graduates willing to continue education at the higher education institutions is also on the rise: in 2002 it reached 286,000 people or 25% of the total admission (in 1995, 112,000 or 18%). Significantly, 80% of the students who come from the secondary technical schools prefer evening classes or correspondence courses, combining training with jobs. Consequently, secondary vocational education not only offers new skills but creates conditions for a personal progress and advancement in the system of education.

The key instrument for raising managerial efficiency in this sector of education was launching branch-oriented and regional development programmes. They now cover 40 regions and 20

ministries. Activities are underway to support the non-governmental sector of the secondary vocational training, resulting in establishing the Association of non-governmental secondary vocational training institutions.

Joint state and public management of the secondary vocational training has won a deserved recognition. There are now 79 regional Boards of Directors and 18 trade associations of the secondary vocational training schools that have earned authority in a sustained development of this sphere.

Social partnership is also the call of the day: 60% of the secondary vocational institutions have social partnership agreements with the employers and regional employment services.

Schools offer a variety of training forms (full-time; combination of full-time and correspondence (evening classes), correspondence-course, external) and their flexible combinations with the introduction of new technologies allowing student to choose an individual learning path.

3. THE HIGHER EDUCATION SYSTEM

3.1 Types of higher education

The higher education system includes educational institutions at university and non-university levels. Education is organized in the form of full-time and part-time (evening and correspondence) studies.

There are 657 state and 387 private higher education institutions at university level including universities, academies and institutes (among them also higher education schools, conservatories and so on) with a total number of students of more than 5,926,000. These institutions instruct students in all fields of knowledge. Among these institutions are 57 classical universities (universities of sciences and humanities), medical, technical, pedagogical and agricultural universities as well. Forty academies instruct their students in different rather wide domains of science, technology and culture.

State and municipal higher education institutions at non-university level include “tekhnikum”s/ “uchilishche”s and colleges. These institutions educate medium-level specialists such as technicians, skilled (senior) nurses and so on. The total number of the state and municipal higher education institutions at non-university level is 2,931 and 1,035 colleges. The total number of students is about 2,445,000.

The higher education system includes state, municipal and non-state (private and founded by public and religious organizations) education institutions. At the present time all state and municipal education institutions are considered as having state accreditation (see sections 3.2 and 8). Besides that, 10 non-state education institutions at university level are state-accredited, too. About 300 recently founded non-state education institutions acting in the sphere of higher education have licenses (permissions) but no state accreditation. They educate mainly students in business, management, law and foreign languages.

Only state-accredited education institutions have the right to issue diplomas of the state model that guarantee full professional and academic rights and are subjects of international agreements concerning the recognition and the establishment of equivalence of credentials. And only state-accredited education institutions have the right to use the seal with the state coat of arms of the Russian Federation. All credentials of the state model about the conferment of qualification or

degree of the same level are considered as equal, independently from the type of education institutions (e.g. university-academy-institute) or the form of ownership (state-municipal-private).

Russian citizens entering state or municipal education institutions and receiving education of a given level receive it free of charge on competitive basis, taking into account results of entrance trials (examinations, tests and so on). They constitute the absolute majority of students. But state and municipal education institutions have also the right to admit a number of students (in addition to the limit set and funded by the founder) in accordance with contracts signed with persons providing tuition fee payment. The success in entrance trials is an obligatory condition for all applicants.

Students of non-state education institutions pay their tuition fees in accordance with contracts signed with the institutions.

3.2 Co-ordination of the higher education

The Federal administrative body of the higher education system is the State Committee for Higher Education of the Russian Federation. The State Committee implements the co-ordinated Federal policy in the sphere of higher, postgraduate and corresponding further education. The Committee drafts and puts into effect the strategy of the development of these domains of education; determines the content of education in state education institutions; ensures the establishment of a unified system of assessment of higher education institutions having different founders and of different organizational and legal forms; collaborates with interested ministries and departments in the drafting of financial policy in this area, in drafting and establishment of the system of the promotion of scientific research; coordinates research and development activities in higher education institutions; and organizes and develops international co-operation in relevant areas of education. In accordance with that the Committee:

- establishes the order for the establishment, reorganization and closing of education institutions;
- establishes, reorganizes and closes education institutions under Federal jurisdiction;
- issues licenses (permissions) to carry out educational activities to education institutions (see section 8);
- conducts the attestation and the state accreditation of education institutions (up to the establishment of the state attestation service);
- forms the structure of the system of education; in cooperation with interested ministries and departments determines the list of specializations and directions of education in the state education system;
- develops Federal components of corresponding state educational standards;
- establishes requirements for a minimum content of professional education programmes of different levels and the level of training of graduates;
- implements the innovation policy in technologies of education;

- takes responsibility for the recognition and the establishment of equivalence of foreign credentials;
- drafts state standard rates for the financing and material provision of education institutions;
- monitors compliance with state legislation in the sphere of education and with State educational standards;
- establishes “Aspirantura” (postgraduate programmes) and “Doktorantura” (programmes of preparation to the second doctoral degree) (see section 4) and closes them in state education institutions and research establishments, except those administered by the Academy of Sciences of the Russian Federation and the Ministry of Education.

The education administrative bodies under Federal ministries and departments, education administrative bodies of subjects of the Federation, and local (municipal) education administrative bodies implement general administrative management of education institution they have founded.

3.3 Institutional governance

An educational institution acts independently in the provision of education, in the selection and placement of staff, and in the scientific, financial, economic and other activities within the limits laid down by the legislation, the activity within the limits laid down by the law, the Standard (Model) Regulations for a higher education institution approved by the Government of the Russian Federation, and by its statute.

The governance of state and municipal education institutions is based on the principles of self-governance and of undivided authority of a responsible person. The general governance of an institution is carried out by an elected representative body: the Council of the education institution, the general meeting of staff, the masters meeting, the Academic council and so on. The direct management of an institution is carried out by a suitably qualified head, Director or Rector. The head of a state and municipal education institution is elected by the institution staff, usually with preliminary agreement of candidatures or subsequent approval of the elected head by the founder.

4. CHARACTERISTICS OF DEGREES AND DIPLOMAS

All education programmes of higher education in state-accredited education institutions must comply with state education standards including requirements for the minimum contents of education and the educational level of graduates.

The academic year consists of two semesters. Each semester of study is concluded by pre-examinations and post-examinations. The curriculum for the majority of semesters implies course work in different disciplines.

The final part of the programme includes final practical work (practice) under the supervision of professionals with additional pedagogical education or teaching experience. The usual duration of the final practice is 8-16 weeks. The results of practical work are graded. Depending on the profile of education, the programme may also include summer practice in different disciplines.

The academic programme of each education level is concluded by the State final attestation (certification) (see section 7) which includes State final examinations and the defense of a qualification work/project (for “Magistr” programme graduate - a “Magistr” thesis).

4.1 Non-university level higher education diplomas

A diploma is conferred after completion of two- or three-year education programmes in “tekhnikum”/ “uchilishche”. A diploma of the profound level is conferred after three or four years in a college. The diploma gives to its holder the right to professional activities as technician, skilled nurse and so on. If a holder of the non-university level diploma enters a university level higher education institution of the same field of study, he or she may ask the administration for permission to have a personal shortened intensive curriculum taking into account previously studied disciplines.

The academic programme in a “tekhnikum”/ “uchilishche” stipulates 90-135 weeks of study (time of examinations not included) with an average 36 class hours a week. Taking into account extra-class studies, a student has about 54 hours of studies a week. That gives a total of 3,200-4,800 class hours.

The academic programme in a college stipulates 135-180 weeks of study with an average of 36 hours of classes a week. Taking into account extra-class studies, a student has about 54 hours of studies a week. That gives a total of 4,800-6,400 class hours.

The time in classes is shared approximately equally between theoretical courses and training on practical skills.

The academic programme is concluded by the defense of a qualification work/project prepared under the guidance of a supervisor of studies/projects and by final examinations.

4.2 University-level higher education diplomas

Intermediate university-level higher education diploma

This intermediate diploma is conferred after at least two years of studies according to the “Bakalavr” programme. The diploma is conferred in all fields of higher education and is issued at the student’s request. The academic programme stipulates at least 72 weeks of studies (time of examinations not included) with an average of 27 class hours a week. Taking into account extra-class studies, a student has about 54 hours of studies a week. That gives a total of about 1900 class hours.

“Bakalavr” diploma

This diploma is conferred after at least four years of studies and confirms the award of the “Bakalavr” degree. The diploma guarantees to its holder rights to carry on professional activity in accordance with the education obtained and to apply for the entrance to the “Magistr” programme. A “Bakalavr” has also the right to continue his/her education within the framework of the “Diplom-specialist” programme and in no less than in a year to receive the “Diplom-specialist” diploma. The “Bakalavr” diploma is conferred in all fields except Medicine.

The “Bakalavr” programme stipulates 144 weeks of studies (time of examinations not included) with an average of 27 class hours a week. Taking into account extra-class studies, a student has about 54 hours of studies a week. That gives a total of about 3900 class hours.

The programme is concluded by the defense of qualification work/project prepared under the guidance of a supervisor of studies/project and by final examinations.

“Magistr” diploma

This diploma is conferred after at least two years of specialized training after the completion of the “Bakalavr” programme and confirms the award of “Magistr” degree. The degree stipulates research and pedagogical activity. The diploma gives rights to carry on professional activity in accordance with the education obtained and to apply for entrance to “Aspirantura” (doctoral programmes).

A two-year programme of training or a “Magistr” on the basis of the completed “Bakalavr” programme stipulates 72 weeks of studies (time of examinations not included) with an average of 14 class hours a week. Taking into account extra-class studies, a student has about 54 hours of studies a week. That gives a total of about 1000 class hours. The programme stipulates also a year of scientific research including practice and a definite term for preparation of a “Magistr” thesis.

The programme is concluded by the defense of a “Magistr” thesis which must be an original research made under the guidance of a supervisor of studies and by final examinations.

“Diplom-specialist” diploma

This diploma is conferred after no less than five years of studies and confirms the award of the qualification of a Specialist in a definite field, for example Mathematician, Physicist, Linguist, Engineer, Teacher, Agronomist, Economist, Physician and so on. Six years of studies are obligatory for medical university level higher education institutions. The diploma gives rights to carry on professional activity in accordance with the education obtained and to apply for entrance to “Aspirantura” (to doctoral programmes). Graduates of medical higher education institutions before starting their independent professional activity must work at least one year of “Internatura” (specialized practice, residency) and then possibly (for some positions) two or three years of “Ordinatura” (clinical studies, internship). The “Diplom-specialist” diploma is traditional in Russia and is conferred in all fields of higher education.

A 5-year programme of “Diploma-specialist” stipulates 180 weeks of studies (time of examinations not included) with an average of 27 class hours a week. Taking into account extra-class studies, a student has about 54 hours of studies a week. That gives a total of about 4,900 class hours.

A 6-year programme of “Diplom-specialist” stipulates about 220 weeks of studies (time of examinations not included) with an average of 27 class hours a week. Taking into account extra-class studies, a student has about 54 hours of studies a week. That gives a total of about 5,900 class hours.

The programme is concluded by the defense of qualification work/project that must be an original work prepared under the guidance of a supervisor of studies/project and by final examinations.

4.3 Diplomas of doctoral programmes

Traditionally there are two doctoral degrees in Russia:

“Kandidat nauk” degree which is the main postgraduate degree awarded mostly after three or four years of “Aspirantura” (doctoral programmes) and after the defense of a thesis that must be a completed scientific research making a significant contribution to the relevant field of sciences or humanities, or proposing substantially new technological (technical, economic and so on) solutions; this degree corresponds to a Doctoral degree in Western Europe and the USA.

The “Doktor nauk” degree is awarded to holders of “Kandidat nauk” degree having achieved outstanding results in their post-“Kandidat nauk” research (like finding a solution to a very important scientific or technological problem, creating a new direction for research and so on) after the defense of a thesis or after the presentation of a monograph summarizing the results; the degree is usually awarded to scientists with established national and international prestige; this degree is used as the second (higher) doctoral degree and often has no equivalent in other countries.

“Kandidat nauk” diploma

A “Kandidat nauk” diploma confirms the award of the “Kandidat nauk” degree and is conferred usually after three or four years of successful studies in “Aspirantura” and the defense of a thesis before a dissertation council (section 7) under a university level higher education institution or a research establishment, established by the resolution of the Supreme Certifying Committee of the Russian Federation. A pursuer of the degree must also pass “Kandidat nauk” examinations in a discipline connected with the area of his/her research, a foreign language and philosophy. The degree gives rights to carry on professional activity in accordance with the education obtained (including the right to apply for occupying vacant positions of Associate Professor at a higher education institution or corresponding positions at a research establishment) and rights to pursue “Doktor nauk” degree presenting the “Doktor nauk” thesis or applying for the entrance to “Doktorantura”.

The “Kandidat nauk” programme does not necessarily stipulate class studies. But in practice the majority of higher education institutions and research establishments training postgraduate students organize for first year students lectures in selected questions of the special discipline, in philosophy, and in pedagogy, and also foreign language lessons. There are usually 35 weeks of lectures and lessons with 8-10 class hours a week. That gives a total of 280-350 class hours.

The personal curriculum of postgraduate studies of a postgraduate student and the topic of his/her thesis is approved by the Rector of a higher education institution or the Director of a research establishment. Each postgraduate student reports to the open meeting of department/laboratory academic staff every year and receives an evaluation of his/her progress.

A “Kandidat nauk” thesis must be a detailed (usually about 150 pages) report on the author’s research providing a new solution for a problem of great importance for the corresponding area

of knowledge, or a summary of the author's scientifically grounded technological, technical, economic developments. The main results of the research must be published at least several months before the defense and copies of abstracts must be sent to leading libraries, higher education institutions and research establishments.

Doktor nauk” diploma

A “Doktor nauk” diploma confirms the award of a “Doktor nauk” degree and is conferred after the defense of a thesis before a dissertation council (section 7) under a university level higher education institution or a research establishment, established by the decision of the Supreme Certifying Committee of the Russian Federation and empowered with the authority to consider “Doktor nauk” theses. Some pursuers (about 20%) pass three or less years of “Doktorantura” full-time studies meant to complete “Doktor nauk” thesis (the entrance to “Doktorantura” is possible only if the thesis is half-completed).

The degree gives the rights to carry on professional activity in accordance with the education obtained (including the right to apply for occupying vacant positions of a Full Professor or of a Head of Department at a higher education institution, or corresponding positions at a research establishment).

The “Doktor nauk” programme does not stipulate class studies.

A “Doktor nauk” thesis must be a detailed (usually about 300 pages) report on scientific research that provides the solution to a scientific problem of great importance for national economics, socio-cultural or political life, or elaborate theoretical tenets that in their entirety may be classified as a new great achievement in the development of a promising direction in a corresponding field of knowledge, or set forth scientifically grounded technological, technical, economical projects that being put into practice may contribute significantly into speeding-up technical progress. The main results of the research must be set out in a monograph or published at least several months before the defense in leading professional magazines. Copies of abstracts must be sent to leading libraries, higher education institutions and research establishments.

4.4 Titles of diploma and degree holders and abbreviations used

Traditionally, holders of higher non-university level education diplomas and of “Diplom-specialist” diplomas do not use any established titles. The education level and qualification according to diploma are specified in the column ‘Education’ in official papers, for example in job applications.

Holders of doctoral degrees use full names of their degrees, for example “Kandidat nauk” in Chemistry, “Doktor nauk” in Technical Sciences, or simply “Kandidat nauk” and “Doktor nauk”. Rather established (though not quite official) abbreviations are:

- “k.f.m.n” - “Kandidat nauk” in Physical and Mathematical Sciences
- “d.f.m.n.” - “Doktor nauk” in Physical Mathematical Sciences
- “k.t.n” - “Kandidat nauk” in Technical Sciences
- “d.t.n.” - “Doktor nauk” in Technical Sciences
- “k.kh.n” - “Kandidat nauk” in Chemical Sciences
- “d.kh.n” - “Doktor nauk” in Chemical Sciences

4.5 Information on credentials

Non-university and university-level higher education diplomas

All higher education diplomas contain information on the diploma holder, the education institution having conferred the diploma, the state attestation commission having carried on the final attestation of the graduate, and the qualification awarded. Diplomas are accompanied with appendixes containing the list of disciplines studied with numbers of class hours, and grades, the list of practices with grades, the list of course works with grades, the theme of the final qualification work/project with the grade, final qualification examinations with grades.

Non-university-level higher education diplomas include:

- Full name of the diploma
- Type of the programme (standard or advanced)
- Kind of diploma (Diploma or Diploma with honours)
- The name of the education institution
- The date of the state attestation commission decision
- Name, Christian name, and patronymics of the holder
- The qualification awarded
- The registration number
- Signatures of the state attestation commission Chairman, the education institution Rector/Director, and the Secretary

University-level higher education diplomas

- (a) Intermediate higher education diploma:
- (1) The face, the main (left) field
 - a) The name of the diploma
 - b) Name, Christian name, and patronymics of the holder
 - c) The previous credential
 - d) The passage of entrance examinations, tests and so on
 - e) The year of the entrance to this programme and the name of the higher education institution of entrance
 - f) The year of the graduation from this programme and the higher education institution of graduation
 - g) Normative term of full-time education
 - h) The direction/specialization
 - i) Course work with grades
 - j) Practice with grades
 - k) "Continued on the reverse"
 - (2) The face, the auxiliary (right) field
 - a) The diploma number
 - b) The registration number
 - c) The date of the issue
 - d) The name of the higher education institution
 - e) "The diploma gives the right to carry on the professional activity and to continue the higher education"

- f) Signatures of the education institution Rector, the Division Dean, and the Secretary
- g) The education institution seal with the state coat of arms
- (3) The reverse
 - a) The list of pre-examinations, and intermediate and final examinations passed, with the total number of class hours for the discipline, and with the final grade
- (b) “Bakalavr”, “Magistr” and “Diplom-specialist” diplomas
 - (1) Left side
 - a) “The diploma is a State document of higher education”
 - b) The registration number
 - (2) Right side
 - a) “The Russian Federation”
 - b) The name of the higher education institution
 - c) Kind of diploma (Diploma or Diploma with honours)
 - d) The diploma number
 - e) “By the decision of the state attestation commission of”
 - f) The date of the decision
 - g) Name, Christian name, and patronymics of the holder
 - h) “awarded the degree” (for “Bakalavr” and “Magistr” or “awarded the qualification” (for “Diplom-specialist”)
 - i) The name of the degree or the qualification
 - j) The direction (for “Bakalavr” and “Magistr”) or the specialization (for “Diplom-specialist”)
 - k) Signatures of the state attestation commission Chairman, and the education institution Rector
 - l) The education institution seal with the state coat of arms

Appendix to a diploma

- (1) The face, the main (left) field
 - a) Name, Christian name, and patronymics of the holder
 - b) Date of birth
 - c) The previous credential
 - d) The passage of entrance examinations, tests and so on
 - e) The year of the entrance to this programme and the name of the higher education institution of entrance
 - f) The year of the graduation from this programme and the higher education institution of graduation
 - g) Normative term of full- time education
 - h) The direction/specialization
 - i) The major
 - j) Course work with grades
 - k) Practice with grades
 - l) Final state examinations with grades
 - m) The elaboration and the defense of the final qualification work with grades

- n) “This diploma gives the right to carry on the professional activity in accordance with the education level and the qualification”
 - o) “Continued on the reverse”
 - p) Number of pages
- (2) The face, the auxiliary (right) field
- a) The name of the higher education institution
 - b) “The appendix to the diploma”
 - c) The registration number
 - d) The date of issue of the diploma
 - e) “By the decision of the state attestation commission of”
 - f) The date of the decision
 - g) “is awarded”
 - h) The degree or degree or the qualification
 - i) The signatures of the Rector, the Dean, and the Secretary
 - j) The education institution seal with the state coat of arms
 - k) The number of the page
- (3) The reverse
- a) The diploma number
 - b) The registration number
 - c) The list of pre-examinations, and intermediate and final examinations passed, with the total number of class hours for the discipline, and with the final grade
 - d) The number of the page

Doctoral programme diplomas

“Kandidat nauk” diploma

- a) Full name of the diploma
- b) The name of the education institution or of the research establishment under that the dissertation council functions
- c) The date of the dissertation council decision and the number of the record of proceedings
- d) Name, Christian name, and patronymics of the holder
- e) The specialization
- f) Signatures of the dissertation council Chairman, and the scientific Secretary
- g) The diploma number
- h) The date of approval of the dissertation council decision by the Supreme Certifying Committee

“Doktor nauk” diploma

- a) Full name of the diploma
- b) The diploma number
- c) The date of the Supreme Certifying Committee decision and the number of the record of proceedings
- d) The specialization
- e) Signatures of the Supreme Certifying Committee Chairman, and the Head Science Secretary

5. SOME SPECIFIC FEATURES OF THE EDUCATION SYSTEM

5.1 *Sequence of the study*

Pre-school education is not obligatory and depends on the parents' desire.

Basic general education (nine years, earlier eight years) is obligatory according to the law. It begins when a child is six or seven years old and finishes when he/she is 15 or 16 years old. Every graduate from the basic general school has the right to continue his/her education at senior high school to receive secondary (complete) general education. A graduate from the basic general school may also enter a vocational school to receive vocational training on the level of a skilled worker for 1.5 to 2 years, or a "professional'ny litsei" to receive vocational training on the same level and secondary (complete) general education for 3 years.

Secondary (complete) general education on the basis of basic general education continues for two years and is finished when a student is 17-18 years old. A graduate from a secondary (complete) general school has the right to apply for the entrance to a higher education institution at university or non-university level.

Entering a university-level higher education institution every applicant has the right to choose for him/herself the 5-year or 6-year "Diplom-specialist" programme or 4-year "Bakalavr" programme, if the latter is available in the given higher education institution. Having received the "Bakalavr" diploma every student has the right to apply to enter the 2-year "Magistr" programme or to pass onto at least one year of training in "Diplom-specialist".

University-level higher education institution graduates with "Diplom-specialist" and "Magistr" diplomas may apply for the entrance into the "Aspirantura". Holders of "Kandidat nauk" diplomas may present "Doktor nauk" theses or apply for entrance to the "Doktorantura".

5.2 *Grading system*

Grades used are: excellent (5), good (4), satisfactory (or low but sufficient) (3), unsatisfactory (or insufficient) (2); and also (mainly for pre-examinations): passed, failed.

6. ADMISSION REQUIREMENTS

Holding a secondary (complete) general education certificate of the state model is an obligatory condition for application for the entrance into the great majority of non-university-level higher education institutions. Some non-university level higher education institutions have extended programmes for students with basic general education, also providing secondary (complete) general education. In that case to have the basic general education institution certificate of the state model is an obligatory condition.

Holding a secondary (complete) general education certificate or the non-university-level higher education institution diploma of the state model is an obligatory condition for application for entrance to university level higher education institutions.

Admittance to non-university and university-level higher education institutions is organized on the competitive basis in accordance with results of entrance trials (examinations, tests and so on). The number, the list and the form (oral or written) of entrance trials is determined by the

education institution admittance rules approved by the education institution Rector or Director. The list of entrance examinations must include Russian or the official language of an autonomous republic where the education institution is situated, if this language is the medium of instruction at the institution. Examinations include material in the scope of the secondary (complete) general school programme. University-level higher education institutions may establish special admittance rules for applicants having secondary (complete) general school certificates with honours (medal) or having other distinctions in the level of training (for example, prizes of national or international competitions in disciplines connected with the education programme). The application for the entrance to two or more state higher education institutions at the same time is illegal. Applicants having got “unsatisfactory” or “failed” in a discipline are not allowed to take further trials and are excluded from the entrance competition.

Rules on admittance of “Bakalavr” diploma holders to “Magistr” programme is of corresponding direction and the list of entrance trials is determined by the education institution.

Holders of university-level higher education diplomas “Diplom-specialist” and “Magistr” diplomas - having demonstrated notable achievements in scientific research are admitted to “Aspirantura” on competitive basis. An applicant for entrance to “Aspirantura” has an interview with the assigned supervisor of studies and has to pass entrance examinations in the special discipline within the scope of “Diplom-specialist” or “Magistr” programme, and also in a foreign language and philosophy.

7. DIPLOMA AND DEGREE CONFERRING AGENCIES

Non-university and university-level higher education diplomas

At a State-accredited higher education institution higher education, diplomas are conferred by the education institution itself according to the decision of the state attestation commission after successful completion of the programme and successful passing of the final state attestation (except for university level intermediate higher education diploma, conferred without the final attestation).

The final attestation includes the defense of the final qualification work/project (of the “Magistr” thesis for a “Magistr”) before the state attestation commission and passing of final state examinations to the same commission. A state attestation commission Chairman is approved by the state Committee for Higher Education or by the State or municipal Body administrative an education institution. The state attestation commission consists of examination commissions giving the final examination in the main discipline or the interdisciplinary examination according to the direction (specialization), and considering qualification works/projects. The composition of final trials is determined by the state education standard in a definite professional education programme. Examination commissions include academics and researchers of the institution of graduation, and also recognized specialists from enterprises, organisations and establishments employing higher education institution graduates of corresponding education profile, and leading academics and researchers from other higher education institutions. Membership to examination commissions is approved by the Rector or the Director of an education institution.

Doctoral programme diplomas

Doctoral degrees are awarded after successful public defense of corresponding theses. Key results of the research must be published in advance, copies of the abstract must be sent to leading libraries, higher education institutions and research establishments.

The “Kandidat nauk” diploma is issued according to the decision of the dissertation council under a higher education institution or a research establishment awarding the “Kandidat nauk” degree after approval of this decision by the Supreme Certifying Committee. Dissertation councils are established by special decisions of the Supreme Certifying Committee in higher education institutions and research establishments widely known by their achievements in the corresponding area of knowledge, and carry on their work under the guidance of the Committee. The Committee monitors their activity and selectively monitors the correctness of the defense procedure. A dissertation council considering “Kandidat nauk” theses includes from 12 to 24 leading specialists in a given discipline, at least half of them holding a “Doktor nauk” degree, and the rest holding a “Kandidat nauk” degree.

A “Doktor nauk” diploma is issued according to the decision of the Supreme Certifying Committee awarding the “Doktor nauk” degree. The decision of the Committee is taken on the grounds of the conclusion of a dissertation council established by the resolution of the Committee for the consideration of “Doktor nauk” theses. Such a council includes from 12 to 24 leading specialists in a given area of knowledge, all of them holding “Doktor nauk” degree. The dissertation council makes its conclusion after the successful defense of the “Doktor nauk” thesis. The Committee monitors the correctness of the procedure and in necessary cases sends the thesis for estimation to independent experts or/and calls the pursuer and experts appointed by the dissertation council to clarify any doubts.

8. ASSESSMENT OF HIGHER EDUCATION INSTITUTIONS

The right of an education institution to carry on education activities commences from the moment of its receipt of the corresponding license (permit). The license is issued on the grounds of examination of an expert commission established by the state education administrative body or on its instructions by a local education administrative body. The subject and the content of the examination are to verify the congruence of the education process conditions proposed by the education institution with the state and local requirements concerning establishment of norms and rules, sanitation and hygiene norms, health care for students and staff, suitability of classes, equipment for education process, education qualification of academic staff, and adequacy of staff. So the license confirms only the possibility of carrying on the education process without touching on its contents, organization and methods. The state education administrative body or a local education body having issued the license ensures monitoring of compliance of an education institution with the conditions specified in the license. The license will be nullified in the case of violation of these conditions.

On the other hand, the certificate of state accreditation confirms sufficient level of education programmes carried out, congruence of the content and quality of training of graduates with the state education standards. The rights of an education institution to issue higher education credentials of the state model to its graduates and to use the seal with the state coat of arms commences from the moment of its state accreditation confirmed by the corresponding certificate.

The state accreditation of higher education institutions is carried on by Federal and departmental (for non-university level higher education institutions) state education administrative bodies on the grounds of the education institution application, and the conclusion on attestation (certification). The attestation of an education institution is made in accordance with its application by the state attestation service with enlistment of academics from leading education establishments and representatives of the public. The attestation is carried on approximately every five years. The goal and the content of the attestation are to verify the congruence of the

content and quality of training of education institution graduates with the requirements of the state education standards. The attestation is a necessary step to accreditation.

9. DIPLOMAS AND PROFESSIONAL RIGHTS

Non-university and university-level higher education diplomas give to their holders rights to carry on professional activity and apply for employment in vacant positions corresponding to their education and qualification. The limitation of these rights is possible only in accordance with the law for professions connected with great responsibility. Thus, a holder of a medical university level diploma receives the right to practise medicine independently only after a year or more of the “Internatura” and (possibly) of the “Ordinatura”.

10. INTERNATIONAL RECOGNITION OF DIPLOMAS AND DEGREES

Russia is a participant of the Convention on the Recognition of Studies, Diplomas and Degrees in Higher Education in States of the Europe Region (Paris, UNESCO, 1979), of the Regional Convention on the Recognition of Studies, Diplomas and Degrees in Higher Education in Asia and the Pacific (Bangkok, UNESCO, 1983), and of the Prague Convention (1972).

Russia has intergovernmental or interdepartmental agreements on mutual recognition and establishing of equivalence of credentials with many countries.

1. COUNTRY PROFILE

The Republic of Singapore includes the main island of Singapore and 58 islets with a total land area of 647.5 square kilometres. The main island is about 42 kilometres long and 23 kilometres wide and accounts for over 580 square kilometres of land area. The country is located approximately 140 kilometres north of the equator at the tip of the Malay Peninsula. Malaysia and Indonesia are Singapore's closest neighbours.

As of 2002, Singapore has a resident population, comprising Singapore citizens and permanent residents as well as foreigners, of approximately 4.16 million people with a population density of over 6,000 residents per square kilometre. The ethnicity of the population is primarily Chinese (76.7%), Malay (14%), Indian (7.9%), and Other (1.4%). At least an additional 100,000 expatriates live in Singapore. The population growth rate in 2001 was about 3.5%.

The official languages are Malay, Mandarin, Tamil and English. Malay is the national language and English is the language of administration and business. Concerted 'Speak Mandarin' campaigns since 1979 and the teaching of Mandarin in school as a formal language have ensured that it has replaced other Chinese dialects as the main Chinese language used in Singapore. A fundamental feature of the education system is the bilingual policy which ensures that every child learns both English and his 'mother tongue'. About half of the population is multilingual and the literacy rate (defined as persons 15 years and over who can read and write) is 93.7% in 2002.

Singapore gained self-governing status from the United Kingdom in 1959. After a brief period as part of the Federation of Malaysia (1963-1965), Singapore became a fully independent nation on August 9, 1965. The nation was admitted to the United Nations and became a member of the Commonwealth of Nations in the same year. Singapore is a parliamentary democracy. The Parliament is unicameral and is elected every five years unless dissolved earlier. Since 1959, the People's Action Party (PAP) has been in control of Parliament, winning all or the vast majority of the 83 seats. This control and continuity of governance has allowed Singapore to develop economically in a politically stable environment. The OECD graduated Singapore to 'developed country' status on January 1, 1996.

Although Singapore is one of the smallest countries in the world, it has become one of the most competitive and affluent, boasting the fifth highest per capita income in the world. This is remarkable considering that its sole natural resource is the deep-water port which has made it the focal point for South-east Asian sea routes. Its geographical location has also rendered it a hub for regional air routes. Economic growth has resulted from concerted government efforts to expand and diversify development as well as to optimise the use of

its primary asset, human resources. The combination of corruption-free political stability, advantageous government policies, and economic growth, based mainly on exports and services, together with a mandatory savings scheme (the Central Provident Fund), allows Singaporeans to enjoy one of the highest standards of living in Asia. In 2002, the gross domestic product (GDP) at current market prices was about SGD\$155.7 billion with per capita Gross National Income (GNI) about SGD\$33,000, placing it squarely in the First World league of nations. The primary economic sectors are financial and business services, manufacturing, construction, and commerce (Economic Survey 1995, p. 101). The unemployment rate which has hovered around a low 3% through the years has recently risen to 4.5% (Dept of Statistics, March 2003) due to the prolonged recession from the late-1990s. Labour force participation is about 65% (males 77.2%, females 53.4%).

Education, health, and social services account for heavy governmental expenditures and are comparable to those in the most highly developed countries. In fact, maximising the use of the nation's human resources through education and training has consistently been closely linked to national socio-economic goals and remains a key policy strategy in keeping Singapore competitive on the world stage.

2. NATIONAL EDUCATION SYSTEM

The provisions for the establishment and management of schools are made in the Education Act (Chapter 175). The Act empowers the Ministry of Education to make regulations regarding the conduct of schools. The main policy objectives for the Singapore education system since the beginning were to bring out the best in every pupil, developing sound moral values, good citizenship, and the skills necessary to meet the demands of a rapidly changing world (Principal's Handbook, 1993). The national curriculum strives to achieve these goals. In the early years of the 21st century, however, there has been a paradigm shift to embrace change, diversity, creativity and innovation in education. Some recent reforms and educational restructuring include the development and imminent implementation (in 2004) by selected elite schools of an Integrated Programme allowing the best students to take advantage of a 6-year 'through-train' education from Secondary 1 to Junior College without being interrupted by the traditional 'O-Level' examinations at the end of Secondary 4. This would ostensibly encourage greater learning opportunities in research, technology, nurturing entrepreneurship and leadership training. Alternative qualifications like the International Baccalaureate will also be offered by a few prestigious schools. The criteria for University admission has accordingly been reviewed to allow greater flexibility in recognizing different strengths and talents of students. For example, besides academic grades, project work would be a new component for consideration.

Pre-school education is not part of the national education system. Pre-schools and kindergartens are run by various parties, including government, community and private commercial organisations. These organisations are required to meet certain standards and need to apply for licensing if classes have more than 10 students.

The year 2003 saw the implementation of compulsory primary education (CE) for Singapore citizens in national schools, with some exemptions for children with special needs, those who are home schooled, and those attending "designated institutions" such as the madrasahs (Muslim religious schools). However, such exempted institutions are benchmarked against average national school performance in the Primary School Leaving Examination (PSLE) and the annual intake capped at a fixed number. The rationale for CE includes giving children "a common core" of foundational knowledge and training as well as "a common educational experience" to help

build a sense of social cohesion. As such, penalties may be enforced on parents who do not comply with the regulation.

At the secondary level, students are streamed into one of three courses based on their PSLE results. These courses feature curricular emphases that are intended to match the different learning abilities and interests of the students. The four-year Special course (for approximately top 10% of the cohort) and Express course (for 45% of the cohort) prepare students for the Singapore-Cambridge General Certificate of Education ‘Ordinary-Level’ (GCE ‘O’) examination. On the other hand, the Normal (Academic) or Normal (Technical) courses (for about 45% of the cohort) prepare students to sit for the GCE ‘Normal-Level’ (‘N’) examination also after four years of schooling. Those who do well for the GCE ‘N’ level are given the option to continue into the fifth year before sitting for the GCE ‘O’ level examinations.

Following the GCE ‘N’ or ‘O’ level examinations, students have three options for post-secondary education depending upon their interests and qualifications. Figure 1: The Singapore Education System summarises these educational paths. Students with better GCE ‘O’ levels may attend two-year junior colleges or three-year pre-university institutes to prepare for the Singapore-Cambridge General Certificate of Education ‘Advanced’ (GCE ‘A’) level examination. Although junior colleges may be considered part of post-secondary education, no diplomas or degrees are awarded. The course work focuses on requirements for the GCE ‘A’ level subjects. These studies provide the type of general education that frequently is found in the first year of university education in other countries. Students also have a choice of five polytechnics in which to pursue diploma qualifications in a variety of courses such as mass communications, design, business, and computer engineering, to name only a few. Those with poorer O-Level results may enrol in Institute of Technical Education (ITE) courses for specialised training or certificate programmes.

Results on the GCE ‘A’ level examination determine the students’ eligibility for tertiary education in one of the three local universities although, as mentioned above, the criteria for university admission is broadening to include the SAT (Scholastic Aptitude Test), project work, and performance in co-curricular activities. With effect from the 2002 A-Levels, the Ministry of Education assumed greater responsibility for the development of syllabuses, examination formats and the awarding of grades, in order to maintain rigorous standards. The proportion of candidates obtaining four As in 2002 was 12.9%, while those who obtained at least one A-Level pass was 99.6%.

3. HIGHER EDUCATION SYSTEM

3.1 Co-ordination of higher education

The Ministry of Education (MOE) is responsible for the co-ordination of education for Singapore. All post-secondary programmes offered by public and non-public institutions or organisations must be approved by the Higher Education Division of the MOE. The MOE also plays a significant role in establishing policy for public higher education institutions.

3.2 Types of higher education institutions

Higher education institutions can be categorised into public and non-public institutions or organisations. Public institutions are established by individual Public Acts. The institutions are operationally autonomous, self-governing, and confer degrees, diplomas, and/or certificates.

Policy guidelines for admission standards, enrolment levels, student payments, etc. are under the purview of the MOE. The MOE also approves requests for new programmes and programme changes. In addition, the MOE recommends the annual budget for public support of higher education to the Parliament.

The public sector offers a comprehensive range of post-secondary education and training opportunities. As shown in Figure 1, different options are available to students depending upon their qualifications. These are divided into three types: the universities, the polytechnics, and the Institutes of Technical Education. The Government almost wholly finances these institutions, and have representatives as members of the governing councils.

The three universities, National University of Singapore (NUS) established in 1980, Nanyang Technological University (NTU) established in 1991, and Singapore Management University (SMU) set up in 2001, require the highest level of qualifications by students and have the national responsibility for the provision of educational facilities at university standards, the advancement and dissemination of knowledge, and the promotion of research and scholarship. The universities primarily offer full-time degree programmes and a few select diploma and postgraduate diploma courses, including some with leading international tertiary institutions such as MIT, Harvard, Stanford and Johns Hopkins. They also have links with over 190 overseas institutions with programmes enabling students to study at overseas universities.

The National University of Singapore offers undergraduate courses through the following 12 faculties:

Architecture and Building	Arts and Social Sciences
Business Administration	Dentistry
Engineering	Law
Medicine	Computing
Science	Design and Environment
Conservatory of Music	University Scholars Programme

Postgraduate studies are conducted within the faculties and the four postgraduate schools of Management, Medicine, Dental Studies, and Engineering. There are also nine national level research institutes and centres affiliated to the University, including the Genome Institute of Singapore, Bioinformatics Institute, Bioprocessing Technology Centre, and Institute of Materials Research and Engineering.

The Nanyang Technological University is organized into colleges, schools, and more than 30 research centres, offering undergraduate and postgraduate programmes through coursework, research and dissertation.

College of Engineering (comprising five engineering Schools)
Nanyang Business School
School of Biological Sciences
School of Communication and Information

Figure 1: The Singapore Education System

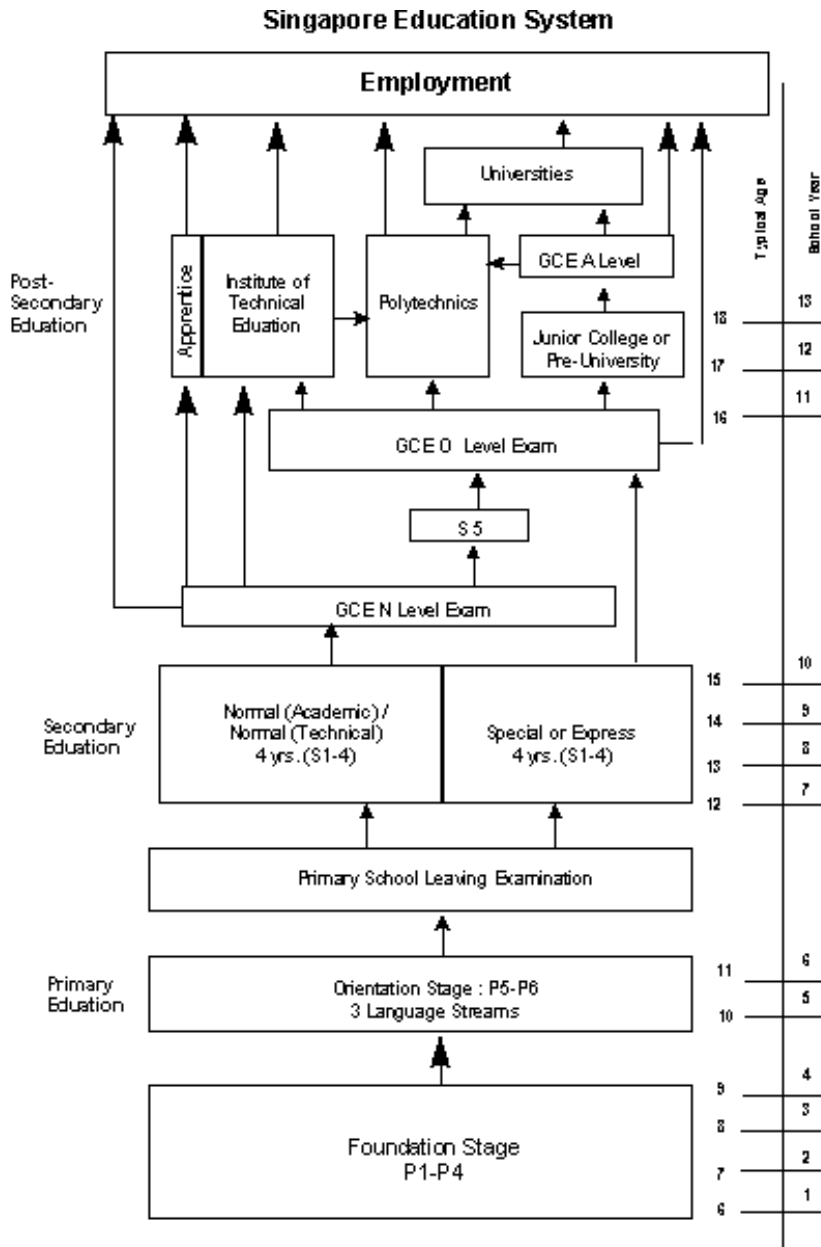

Adapted from : Tan, 1991, Annex A

Figure 3.1 : Singapore Education System

The National Institute of Education (NIE), which is part of the NTU, is the sole educational institution offering a variety of full-time and part-time teacher education and educational administration programmes for training pre-service and in-service teachers for national schools. These include the four-year Bachelor of Arts/Science (Education), as well as postgraduate diploma and degree courses such as the one-year Postgraduate Diploma in Education, two-year Postgraduate Diploma in Physical Education, Advanced Postgraduate Diplomas, Diploma in Departmental Management, Master of Arts/Science and Doctor of Philosophy.

The Singapore Management University (SMU) is the first to offer an American-style university education, being modeled on the Wharton Business School of the University of Pennsylvania. It presently offers the Bachelor of Business Management (B.B.M.), Bachelor in Accountancy (B.Acc.), the Bachelor of Science (Economics), and the M.Sc. in Applied Finance programmes, as well as the M.Sc. and Ph.D. programmes by research.

Five polytechnics (Nanyang, Ngee Ann, Republic, Singapore, and Temasek Polytechnic) provide a wide range of full-time and part-time programmes leading to diploma, advanced diploma, and certificate qualifications. The focus of the polytechnics is on the education and training of middle-level and supervisory personnel to support the technological, economic, and social development of Singapore. The polytechnics offer programmes in engineering, technology, and business studies as well as specialised programmes such as design, health science, optometry, shipbuilding, and information technology.

The last type of public post-secondary education consists of the Institute of Technical Education (ITE) set up in 1992, which offers full-time technical and vocational education and training programmes for school-leavers and part-time Continuing Education and Training programmes for working adults. Full-time training in technical and business studies courses is available for students completing secondary school with GCE 'O' and 'N' qualifications. These courses culminate in the award of certificates accepted in industry and commercial enterprises.

The non-public sector of higher education includes a diverse set of private institutions, professional organizations, and quasi-governmental bodies. As noted above, post-secondary programmes available through the non-public sector must be approved by the Ministry of Education. The approval process ensures provision of appropriate facilities and management structure as well as evaluating the content of the programme. The providers usually are independent, self-regulated, and self-financing; they may or may not be profit-making. These institutions offer diploma, advanced diploma, and/or certificate programmes in business and technical fields of study. The qualifications are awarded in the name of the organization. With one exception, no degrees are conferred directly by these organizations.

Specialised diploma and certificate programmes are directed by professional organizations, such as the Singapore Hotel Association Training and Education Centre, Singapore Insurance Institute, and the Institute of Certified Public Accountants of Singapore, and quasi-governmental bodies, such as the National Maritime Academy and the SEAMEO Regional Language Centre. These programmes must meet the requirements and standards set by the professional group. The SEAMEO Regional Language Centre also is the only non-public institution to offer a degree programme, a Master of Arts in Applied Linguistics.

Private educational institutions provide a wide range of educational opportunities, including special education, correspondence and tutoring schools, fine arts, language, offering certificate and diploma qualifications. In addition, some private organisations serve as programme

facilitators for foreign universities. These organizations co-ordinate the teaching and tutoring required for degree programmes offered by foreign universities. Students receive degrees conferred by the university and not by the local organisation. One example is the Singapore Institute of Management (SIM). SIM provides diploma, graduate diploma, and certificate programmes in management studies. In addition, SIM co-ordinates numerous business-related bachelor's, master's and doctorate degree programmes offered by universities from Great Britain and Australia. For part-time students desiring a bachelor's degree, SIM also provides access to Open University degree programmes, accredited and awarded by the United Kingdom's Open University.

3.3 Institutional governance

The structure of institutional governance is very similar among the universities and polytechnics and is defined in the Public Acts establishing the individual institutions. Each institution is governed and managed by a Council which is appointed either by the Chancellor of the universities (the President of Singapore) or the Minister-in-charge of the polytechnics. The Council for a particular institution includes the President of the university or the Principal of the polytechnic and representatives from the administration and faculty of the institution, the Government, and the private sector.

The Public Act also establishes a Senate or Academic Board which is responsible for the control and direction of academic programmes, research, and examination, and has the power to award degrees, diplomas and certificates.

Within the policy guidelines established by the Government, institutions carry out typical activities of:

- selecting and admitting students,
- developing curricular content and methods of instruction,
- establishing examination policy and procedures,
- regulating conditions of service for staff,
- maintaining the facility,
- and managing financial affairs.

4. CHARACTERISTICS OF DEGREES AND DIPLOMAS

4.1 Types of degrees and diplomas

Certificate

Certificates come in many forms. Within the public sector, certificates received from the Institute of Technical Education recognise completion of a technical or business training course. The courses require one or two years of study and assure certain levels of skill attainment. ITE certificates awarded with merit are accepted by polytechnics as qualifications for diploma courses. Certificates offered by polytechnics tend to be post-diploma qualifications in very specialised fields of study.

Within the non-public sector, a wide variety of certificates are available. The range includes short courses of study (one-year of part-time study) to two-year full-time courses. Certificates may reflect a combination of study, practice, and examination; or success on a single aspect. The type of course and the reputation of the organisation conferring the certificate must be considered in any evaluation of the ability of a recipient.

Diploma

For most skilled, technical, or mid-level employment and some professional positions, the diploma indicates complete qualification. Study programmes are available in various fields of business, engineering, computer studies, accountancy, banking, biotechnology, information technology, design, production, quality, and health sciences. Students having GCE 'O' level qualifications make up the majority of participants in diploma programmes. Diploma courses at the polytechnics and the National Institute of Education normally necessitate three years of full-time study. Students with GCE 'A' level qualifications may be admitted to the second year of some programmes.

The specialised diploma programmes offered by the non-public sector require two to three years of study, usually on a full-time basis, and have admission standards similar to the polytechnics. Some of the more generalist diplomas may be one-year programmes.

The polytechnics and universities also offer advanced diplomas or postgraduate diplomas. The first requires prior completion of a specific diploma programme. The postgraduate diploma has an undergraduate degree prerequisite. These supplementary programmes are usually of one or two years in duration for purposes of professional education or further training.

Bachelor's Degree

The bachelor's degree is awarded after the successful completion of a study programme at a university or sponsored by a university. Students must have GCE 'A' level qualifications for admission to the university degree programmes. The course involves from three to five years of full-time study, depending upon the subject. The degrees indicate the level of achievement by including the classification of the degree. The indication may be of *pass with merit* or the class of honours. An honours classification may require enrolment in special modules and/or additional study as well as a high achievement level. An *aergratat* degree may be awarded to a student that has completed the course of study but has been unable to take the final examinations necessary for the award of the regular degree.

Master's Degree

Upon completion of a programme of advanced study beyond the undergraduate level, a master's degree may be awarded by a university. The postgraduate programme of two to three years may be undertaken by research or project, course work, dissertation or a combination of these forms of study. Final assessment may be through oral or written examination and/or evaluation of thesis. The normal minimum entry qualifications as a master's candidate by research are a bachelor's degree with honours at least at second class level and the ability to pursue research in the proposed field of study. The normal minimum entry qualification as a master's candidate by course work and dissertation is a bachelor's degree or its equivalent, though requirements do vary from course to course.

Doctoral Degree

Doctoral degrees normally are awarded on the basis of research work, regardless of the field of study, and require two years or more of study and/or research leading to the presentation of a thesis. Included in this format are the Doctor of Philosophy (Ph.D.), Doctor of Medicine (M.D.), Doctor of Surgery (D.Surg.), and Doctor of Dental Surgery (D.D.S.). The Ph.D. in Business requires a combination of course work and dissertation. Three other doctoral degrees, Doctor of Letters, Doctor of Laws, and Doctor of Science, are awarded on the basis of published works. The usual minimum entry qualifications for admission to a doctoral degree programme are a master's degree and the ability to pursue research in the proposed field of advanced study.

Table 1 illustrates the diversity of higher education institutions and their offerings.

Table 1. Higher Education Institutions and Offerings

Types of Higher Education Institutions	Degrees	Diplomas	Certificates
Universities	X	X	
Polytechnics		X	X
Institute of Technical Education			X
Professional Organisations		X	X
Quasi-Government Bodies		X	X
Private Institutions	*	X	X

*Degree conferred by a foreign university.

4.2 Title and abbreviation of degrees and diplomas from universities

As typically found elsewhere, degrees are conferred with the titles of Bachelor, for first degrees; Master, for advanced degrees, and Doctor, for academic degrees. In specifying the degree, the disciplinary area is included in the name. The disciplinary area may identify a major disciplinary group or an individual discipline and/or sub-disciplines. In abbreviated titles of degrees, the B, M, or D usually appears first followed by disciplinary information, but exceptions are common. The titles and abbreviations for diplomas utilise a similar pattern. Figure 3 in Section 5.3 provides the titles and abbreviations for university study programmes.

4.3 Information in the degree/diploma document

While the information included in the certifying document is not specified by law, the document provides the following data:

- name of person receiving the award,
- award and title conferred,
- classification of the title,
- discipline of study or programme,
- date of award,
- the awarding institution, and
- signatures of those authorising the award.

5. STUDY PROGRAMMES OFFERED BY SINGAPORE UNIVERSITIES

5.1 Number of credits

Credit or measures of work required for degree or diploma completion are not standard across or within the universities. Various terminology is used. The academic unit system is being implemented at Nanyang Technological University. An academic unit (AU) is equal to one hour of lecture/tutorial per week or three hours of laboratory/fieldwork per week. Each subject is assigned a certain number of AUs.

At the National University of Singapore, a module system is being adopted. A module typically requires three student contact hours per week. In departments not using the module system, the term *subject* is used to describe a particular topic that may be taught over one or two semesters.

5.2 Sequence of study

Although most study programmes have a specified sequence of courses, there is no common standard among the multitude of programmes. Typically, students will proceed through the course with the sequence depending on the schedule of offerings. There also may be prerequisites or introductory courses required prior to taking certain classes. Examinations will be taken at the end of the course or academic term. Sequences may differ among students if internships or other practical experiences are not available to all students at the same time.

5.3 Practical experience

Practical experience plays a significant role in many study programmes, particularly professional programmes. The length of experience varies from a single eight-week component to teaching practice required each term to project work accomplished over a year or two. In most courses, the practical experience is a period of attachment or internship in the workplace of the profession. The goal is to expose students to real work situations, to allow them to apply the skills and techniques learned in the classroom, and to instill a sense of professionalism. Successful completion of the practical experience is an essential part of the programme.

5.4 Grading and evaluation

As noted previously, the classification of degrees indicates the level of achievement in the study programme. Depending upon the degree, the possible classifications are as follows:

- Bachelor's Degree
- 1st Class Honours
- 2nd Class Honours (Upper)
- 2nd Class Honours (Lower)
- 3rd Class Honours
- Pass with Merit
- Pass

The classification of honours is determined by the average marks students obtain in their first attempt at the course and does not include marks obtained for free electives or classes taken at other institutions. Individual modules usually are graded using an A through F system. No credit is earned for grades 'E' or 'F'. Calculation of cumulative grade point average varies by institution. The average marks or per centage necessary to achieve a particular class of honours may change over time.

6. ADMISSION REQUIREMENTS

Access to all types of higher education is based primarily upon the results of the GCE examinations. For the Institute of Technical Education certificate programmes, students must have GCE 'O' or 'N' level qualifications. Admission requirements at the polytechnics differ

depending upon the diploma course to which the student is applying. Minimum eligibility is related to scores on different parts of the GCE 'O' level examinations, such as English, mathematics, physical science, physics, chemistry, biology, and art. Generally, a student must have a score of 1-6 (1 being the best score, 7 being passing) in the required subject areas for a particular course. The ranking of applicants is based on the aggregate of scores in English, two relevant subjects, and best two other academic or technical subjects. Selection for admission tends to be based first, on merit and second, on the order of choice of courses by the student.

Entry requirements follow a similar pattern for the universities. Applications for admission are considered in an exercise conducted jointly by the two universities. Admission is based on the Singapore Cambridge GCE 'A' level or its equivalent. Students must obtain passes examination (scored from A to F) in at least two subjects at the advanced level and a satisfactory grade on the general paper offered at the same examination. English medium candidates must have received a minimum grade of 6 in English on the GCE 'O' level examination; and a minimum grade of D in a second language on the GCE 'A' level examination, or a minimum grade of 7 in a first language on the GCE 'O' level examination. Non-English medium candidates must have received a minimum grade of 7 in English (as a first language) on the GCE 'O' level examination.

Selection for admission is based on competition among all eligible candidates for the places available in the course concerned. Students indicate five course choices in order of preference on their application. The pass levels on the examination and paper are translated into an aggregate score which is used to rank the candidates. This score, the candidate's course preferences, and the number of places available in a course are the primary determinants of admission to a course. Additional selection criteria attempts to ensure an equitable distribution of the brightest students and genders across courses. Interviews of candidates also may be required for admission to programmes, such as medicine, dentistry, law, architecture, and education.

Foreign students applying for admission to university must hold passes in two subjects at Advanced level and a pass in the General Paper in the GCE A-Level examination. For Polytechnic

7. DEGREE CONFERRING AGENCIES

As noted previously, degrees are conferred by the individual institutions as authorised by statute. In the case of degrees offered in Singapore by foreign institutions, degrees are conferred by the foreign institution and not the local co-ordinating organisation.

8. ASSESSMENT OF HIGHER EDUCATION INSTITUTIONS

Once a study programme has been approved by the Ministry of Education, no further assessment of the programme or accreditation of the offering institution occurs by the MOE. Public and non-public organisations are treated similarly. Various review processes are not considered necessary given the small size of Singapore and its higher education system, the competitive nature of the environment, and economic pressures. Within the public universities, reviews of programmes occur on a regular basis. The use of external examiners in some programmes also help ensure quality.

9. DEGREES AND PROFESSIONAL COMPETENCE

In most cases, degree holders are entitled to practice professionally after graduation without further examination. Some professions do require supervised periods of practice (accountancy, architecture, medicine) or a postgraduate practical course (law) prior to full recognition. Standards for practice are set by the professional organizations and programmes usually strive to meet and are recognised as meeting these standards.

10. INTERNATIONAL RECOGNITION OF DEGREES

Singapore participates in bilateral and multilateral agreements regarding the recognition of degrees and diplomas although not in the UNESCO Regional Convention on the Recognition of Studies, Diplomas and Degrees in Higher Education in Asia and the Pacific. Singaporean degrees in medicine and dentistry are recognised in the United Kingdom by the General Medical Council and the General Dental Council and the United States by the Educational Commission for Foreign Medicine Graduates as meeting educational requirements for the licensing examination. The bachelor's degrees in architecture also are accepted by the Royal Institute of British Architects for exemptions from select parts of the examination. Recognition of foreign degrees rests with the appropriate professional organization. The Higher Education Branch, MOE, is responsible for dealing with international co-operation and exchanges in higher education.

REFERENCES

- International Association of Universities/UNESCO. International Centre on Higher Education.
- Ministry of Education website. <http://www.moe.edu.sg>
- Ministry of Trade and Industry. (1996). *Economic Survey of Singapore, 1995*. Singapore: SNP Publishers.
- National University of Singapore. (1996). *Postgraduate Studies, 1995-96*. Singapore.
- National University of Singapore. (1996). *Prospectus, 1996-97*. Singapore.
- National University of Singapore website. <http://www.nus.edu.sg>
- Nanyang Polytechnic. (1996). *Prospectus, 1996-97*. Singapore.
- Nanyang Technological University. (1996). *Undergraduate Catalogue 1996-97*. Singapore.
- Nanyang Technological University. (1995). *University Statutes and Regulations 1995-96*. Singapore.
- Nanyang Technological University. (1995). *Prospectus for Graduate Programmes, 1995-96*. Singapore.
- Nanyang Technological University, National Institute of Education. (1995). *General Information, 1996-97*. Singapore.

Ngee Ann Polytechnic. (1995). *Prospectus, 1995-96*. Singapore. *Principal's Handbook*. (1993). Singapore: Ministry of Education.

Selvaratnam, V. (1994). *Innovations in Higher Education : Singapore at the Competitive Edge*. Washington, DC: World Bank.

Singapore: Facts and Figures. (1994). Singapore: Ministry of Information and the Arts.

Singapore Polytechnic. (1995). *Prospectus, 1996-97*. Singapore. Tan Keng Yam, T. (1991). *Improving Primary School Education: Report of the Review Committee, Address*. Singapore: Ministry of Education.

Tan Tiong Thiam. (1996). Deputy Director, Higher Education Branch, Ministry of Education. Interview, 25 April.

Temasek Polytechnic. (1995). *Prospectus, 1995-96*. Singapore.

Yearbook of Statistics Singapore. (2003). Singapore: Department of Statistics, Ministry of Trade and Industry.

1. COUNTRY PROFILE

Thailand is situated in the Southeast Asian mainland with an area of 513,115 square kilometres. The word “Thai” means “free” and therefore “Thailand” means “Land of the Free”. Thailand borders Lao PDR and Union of Myanmar to the north, Cambodia and the Gulf of Thailand to the east, Union of Myanmar and the Indian Ocean to the west, and Malaysia to the south. The population is 64.2 million (2002) with an annual growth rate of about 1.09 per cent. Thailand is governed by a constitutional monarchy with a parliamentary form of government. The national language spoken by almost 100 per cent of the population is Thai. Other principal languages are Chinese, English, and Malay.

Religion plays a very important role in Thai life. Buddhism is the national religion. About 95 per cent of the population are Buddhists, while about 4 per cent are Muslims, 0.5 per cent are Christians, and the remainder are Brahmins, Hindus, Sikhs, Confucians and others. Despite the fact that Buddhism is the state religion and that the King must be of the Buddhist faith, both the King and the government support all religions accepted by the people. It can be said that there is total religious freedom in Thailand and all major religions can be found in practice.

In 2002, the Thai economy expanded at 5.2 per cent from the previous year. In the last quarter, real Gross Domestic Product (GDP) grew by 6.1 per cent compared with the same period in 2001, slightly higher than the rate of 5.8 per cent in the third quarter despite heightening concern over the conflict between the United States and Iraq as well as conflict between the United States and North Korea, which have led to rising oil prices in the world market, and some economic slowdown in advanced economies, namely the United States, Japan and the European Union.

Seasonally adjusted real GDP grew by 2.0 per cent compared with the previous quarter, higher than 1.2 per cent growth rate in the third quarter. All components of the demand including private consumption and investment, government consumption and public investment, exports and imports volume in seasonally adjusted terms, however, expanded at lower rates than in the third quarter. The more significant slowdown in import volumes led net exports contributing more to economic growth. All things considered, the components of domestic demand, thus, underpinned economic slowdown in the last quarter of the year.

In 2003, Thai economy would continue to expand satisfactorily and is projected to be in the range of 4.03-5.0 per cent growth rate, owing primarily to strong domestic demand, private consumption in particular, while exports become a secondary supporting factor. Economic stability remains favorable, with 1.6 per cent inflation rate and high international reserves of almost three-fold of short-term external debts (<http://www.nesdb.go.th>).

2. NATIONAL EDUCATION SYSTEM

The Thai education system can be classified into 3 types: (1) formal education; (2) non-formal education ; and (3) informal education (Office of The National Education Commission, 2002: 17-23).

2.1 Formal Education

This type specifies the aims, methods, curricula, duration, assessment, and evaluation conditional to its completion. Formal education services are provided by both public and private bodies to those inside the school system, such as., early childhood development institutions and schools. It is divided into 2 levels: basic education and higher education.

Basic Education

Basic education is provided before higher education covering pre-primary, six years of primary education, three years of lower secondary education, and three years of upper secondary education. Basic education is provided by the following institutions:

- *Early childhood development institutions* such as childcare centres, child development centres, initial care centres for disabled children or those with special needs and early childhood development centres operated by religious institutions or by other agencies.
- *Schools* such as public schools, private schools, and those under the jurisdiction of Buddhist or other religious institutions; and
- *Learning centres* such as those organized by non-formal education agencies, individuals, families, communities, community organizations, local administration organizations, private organizations, professional bodies, religious institutions, enterprises, hospitals, medical institutions, welfare institutes and other social institutions.

Compulsory education is nine years.

Higher Education

Higher Education is provided in universities, institutes, colleges or other types of institutions. It is divided into two levels: lower-than-degree level and degree level.

- *Lower-than-Degree or Diploma* level is mainly offered by colleges and institutes such as, Rajabhat Institutes, Rajamangala Institutes of Technology, community colleges, public and private vocational colleges, as well as colleges of physical education, dramatic arts and fine arts. The majority of courses offered are related to vocational and teacher education which require two years of study.
- *Degree* level study programmes require two years of study for students who have completed diploma courses, and four to six years of study for those finishing upper secondary education or equivalent courses. The first professional qualification is a bachelor's degree obtained after four years of study. In the fields of architecture,

painting, sculpture, graphic arts, and pharmacy, five years of study are required for a bachelor's degree. The fields of medicine, dentistry, and veterinary science require six years of study. In some of these professions, additional study is required before professional qualifications are awarded.

Advanced studies of at least one but generally two years, combined with a thesis, lead to the award of a master's degree. A doctorate is required an additional three years of study following a master's degree combined with a dissertation. An advanced diploma or certificate may be obtained after one or two years of course work. It is designed for students who already possess a degree or professional qualification.

2.2 Non-Formal Education

This type has more flexibility than formal education in determining the aims, modalities, management procedures, duration, assessment and evaluation conditional to its completion. The contents and curricula for non-formal education can be adjusted to meet the needs of individual groups of learners. Provided by both public and private organizations to those outside the school system, non-formal education services can be divided into 5 following types:

- Non-Formal Education for Pre-School Children
- Fundamental Education for Literacy
- General Non-Formal Education
- Vocational Non-Formal Education
- Quality of Life Improvement Activities

2.3 Informal Education

This type of education enables learners to learn by themselves according to their interests, potential, readiness and the opportunities available from individuals, society, environment, media, or other sources of knowledge as follows:

- Informal education programmes provided by libraries, museums, and science/technology centres, etc., as well as by mass media such as, radio, television, newspapers and magazines, etc.
- Informal education programmes of community learning networks such as, community learning centres, village reading centres, sub-district health offices, sub-district agricultural offices, as well as natural learning sources in each community.
- Learning from various sources including local wisdom, local media, families and networking through cooperative activities.

It could be said that all ministries are involved in providing informal education to promote lifelong learning. The services provided include educational activities or academic and professional programmes for different target groups relating to the responsibilities of each ministry.

3. HIGHER EDUCATION SYSTEM

3.1 Types of higher education institutions

Thai higher education institutions can be classified into five categories:

- **Public universities and institutes under the supervision of the former Ministry of Universities Affairs.** There are 24 public universities and institutes under this category (July, 2003). Of these 24 public higher education institutions, there are 21 universities and 3 institutes. The National Institute of Development Administration (founded in 1966) offers only graduate programmes of study. Of these 24 public universities and institutes, there are two open universities: Ramkhamhaeng University (founded in 1971) and Sukhothai Thammathirat Open University (founded in 1978). There are also four autonomous universities : Suranaree University of Technology (founded in 1990), Walailak University (founded in 1992), Mae Fah Luang University (founded in 1997), and King Mongkut's University of Technology Thonburi (upgraded to be an autonomous university in 1998).
- **Private universities and colleges under the supervision of the former Ministry of University Affairs.** There are 54 private universities and colleges as of July 2003. Of these 54 higher education institutions, there are 26 private universities and 28 private colleges.
- **Institutes and colleges under the Ministry of Education,** such as Rajamangala Institute of Technology, Rajabhat Institutes, Pathumwan Institute of Technology, community colleges, technical and vocational colleges, and agricultural colleges are under the Ministry of Education.
- **Colleges under other ministries.** Physical education colleges are under the Ministry of Tourism and Sports; dramatic arts colleges and fine arts colleges are under the Ministry of Culture; nursing colleges are under the Ministry of Public Health; and professional training institutions are under other ministries such as military and police academies are under the Ministry of Defence and Interior, respectively.
- **Specialized training institutions** (such as, the Asian Institute of Technology, Mahamongkut Buddhist University, and Mahachulalongkorn Buddhist University).

In this paper, however, the emphasis is on providing detailed information on public universities and institutes, and private universities and colleges under the first and second categories.

3.2 Co-ordination of Higher Education

The new Ministry of Education was established on July 7, 2003 by combining the former Ministry of University Affairs, the former Ministry of Education and the Office of National Education Commission together. This new Ministry of Education has the powers and duties for promoting and overseeing all levels and all types of education including higher education. The administrative structure of the Ministry is composed of six organizations: (1) the Minister's Office, (2) the Permanent Secretary's Office, (3) the National Council of Education, (4) the

Commission on Basic Education, (5) the Commission on Vocational Education, and (6) the Commission on Higher Education.

The Commission on Higher Education is responsible for proposing policies, development plans and standards for higher education in line with the National Economic and Social Development Plan and the National Scheme of Education; mobilization of resources; monitoring; inspection; and evaluation of the provision of higher education; taking into consideration academic freedom and excellence of degree-level institutions in accordance with the laws on the establishment of such institutions and other pertinent laws.

At the institutional level, there are two associations that co-ordinate public universities and institutes, and private universities and colleges: the Council of University Presidents of Thailand and the Association of Private Higher Education Institutions of Thailand (Ministry of University Affairs, 2000: 31). The Council of University Presidents of Thailand was established in 1972 for high-level executives of public universities and institutes to share opinions and experience through regular meetings. It also serves as the co-ordinating arm of public universities and institutes for mutual assistance and cooperation on development projects such as staff development. In addition, it makes recommendations on relevant issues to the Commission on Higher Education and the government. The Association of Private Higher Education Institutions of Thailand was established in 1959. This Association seeks to create greater cooperation between individual institutions as well as between its members and the government.

3.3 Institutional governance

Each public university or institute has its own Act empowering the University Council to function as the governing body. Under the University Council is the President who is responsible for university administration. The President operates the university or institute according to the policies laid down by the University Council. As specified by the University Act, the University Council has the powers and duties to control and supervise the general affairs of the university and specifically:

- to lay down the university policy related to education, research, public services, and preservation of arts and culture;
- to issue university rules and regulations and entrust any university offices with the duty to issue rules and regulations on any particular matter that shall apply to those university offices;
- to approve the award of degrees, graduate certificates, diplomas, and certificates;
- to consider and propose the establishment, merger and abolition of the Office of the Campus, Graduate School, faculty, college, institute, academy or centre;
- to approve or terminate the affiliation of advanced learning institutes and research institutes;
- to approve curricula in conformity with standards prescribed by the Ministry of Education;

- to propose the appointment by the King and dismissal of the University Council Chairman, Member of University Council, the President, Professor and part-time Professor;
- to appoint and dismiss the Vice-President, Dean, Director of the College, Director of the Institute, Director of the Academy, Director of the Centre, or Head of the Unit called by other names equivalent to Faculty, Emeritus Professor, part-time Associate Professor, part-time Assistant Professor, and part-time Lecturer;
- to appoint and dismiss Committee Chairman or Member Committee on the Promotion of the University Affairs;
- to approve budgetary funds derived from the income of the university;
- to issue rules and regulations relating to the management of finance and properties of the university;
- to appoint a committee for considering and giving opinions on any matter or to perform any act within the powers and duties of the University Council;
- to consider and approve university affairs as proposed by the President and may entrust the President to act on any matter within the powers and duties of the University Council; and
- to approve other activities related to university affairs which have not been specifically entrusted to any particular persons.

The University Council is empowered to grant degrees, graduate certificates, diplomas and certificates at the institutional level.

For private higher education institutions, each private institution has its own council which is the administrative body responsible for the general operation of the institution as well as organizing its internal administrative structure. The Council provides policy guidance for long-term planning and formulates control procedures. It also allocates funds and screens proposed budgets as well as curriculum design and revision of the curriculum. The Council functions to include the setting up of new academic disciplines, establishment of campuses, appointment and removal of chief executives, and approval and conferment of degrees and diplomas. (Assumption University 2001:7). The Private Institution Council like the University Council, approves and grants degrees and diplomas.

4. CHARACTERISTICS OF DEGREES AND DIPLOMAS

4.1 Types of degrees and diplomas

The following are the types of degrees and diplomas awarded:

- Certificate
- Diploma
- Postdiploma Certificate (usually offered in the field of Health Sciences)
- Bachelor's

- Graduate Diploma
- Master's
- Higher Graduate Diploma
- Doctoral

4.2 Title and abbreviation of the degrees and diplomas

As for the field of Natural Science and other fields of study such as Pharmaceutical Science, Allied Health Science, Medical Technology, and Agriculture; the title and abbreviation of the degrees and diplomas are as follows:

- Bachelor of Science (.....)
B.S. (.....) or B. Sc.(.....)
- Graduate Diploma in
- Grad. Dip. in
- Master of Science (.....)
M.S. (.....) or M. Sc. (.....)
- Doctor of Philosophy (.....)
Ph.D. (.....)

In the fields of Humanities and Social Sciences such as Political Science, Economics, Sociology, Anthropology, Arts, Liberal Arts, and Communication Arts, the title and abbreviation of the diplomas are as follows:

- Bachelor of Arts (.....)
B.A. (.....)
- Graduate Diploma in
- Grad. Dip. in
- Master of Arts (.....)
M.A. (.....)
- Higher Graduate Diploma in
- Higher Grad. Dip. (.....)
- Doctor of Philosophy (.....)
Ph.D. (.....)

For professional degrees in the following fields, the title and abbreviation are as follows:

Medicine

- Doctor of Medicine
M.D.
- Graduate Diploma in Clinical Science
Grad. Dip. in Clin. Sc.
- Master of Science in Clinical Science (.....)
M. Sc. in Clin. Sc. (.....)
or Master of Science (.....)
M. Sc. (.....)
- Doctor of Philosophy (.....) or
Doctor Science (.....)
Ph.D. (.....) or D.Sc. (.....)
- Certificate of Proficiency Board in Clinical Specialization
Cert. of Proficiency Board in Clinical Specialization

Dentistry

- Doctor of Dental Surgery
D.D.S.
- Graduate Diploma in Clinical Science (.....)
Grad. Dip. in Clin. Sc. (.....)
- Master of Science in Clinical Science (.....)
M.Sc. in Clin. Sc. (.....)
or Master of science (.....)
M.Sc. (.....)
- Higher Graduate Diploma (.....)
Higher Grad. Dip. (.....)
- Doctor of Philosophy (.....)
Ph.D. (.....)

In other professional degrees such as Engineering, Teacher Education, Architecture, Law, and Nursing, the title and abbreviation of the degrees are as follows:

Bachelor's Degree Programme

- Bachelor of Engineering (B.Eng.)
- Bachelor of Education (B. Ed.)
- Bachelor of Architecture (B.Arch.)
- Bachelor of Laws (LL.B.)
- Bachelor of Nursing Science (B.N.S.)

Master's Degree Programme

- Master of Engineering (M. Eng.)
- Master of Education (M.Ed.)
- Master of Architecture (M. Arch.)
- Master of Laws (LL.M.)
- Master of Nursing Science (M.N.S.)

Doctoral Degree Programme

- Doctor of Engineering (D. Eng.)
- Doctor of Philosophy (Ph.D.) (for Education and Architecture)
- Doctor of Laws (LL.D.) or Doctor of Jurisical Science (J.S.D.)
- Doctor of Nursing Science (D.N.S.)

4.3 Information contained in the degree document

The following information is generally contained in the degree certificate:

- the awarding institution
- approval of the University Council to confer the degree to
- the name of graduate
- the degree awarded
- the field of study (and specialization, if any)
- mention of first class honours or second class honours (if any)
- honours and privileges appertaining to this degree
- date, month, and year
- signature of the Chairman of the University Council

- signature of the President of University
- signature of the Dean
- signature of the University Council Secretary or Registrar

5. STUDY PROGRAMMES OFFERED BY SINGAPORE UNIVERSITIES

5.1 Number of credits and duration of programmes

Level of Education	Total Number of Semester Credits	Duration not more than
Diploma	90 – 112	6 academic years
Bachelor's (4 years)	120 – 150	8 academic years
Bachelor's (5 years)	150 – 188	10 academic years
Bachelor's (6 years)	210 – 263	12 academic years
Graduate Diploma and Higher Graduate Diploma	not less than 24	3 academic years
Master's	not less than 36	5 academic years
Doctoral (for Bachelor's Degree graduates)	not less than 72	8 academic years
Doctoral (for Master's Degree graduates)	not less than 48	5 academic years

5.2 Sequence of the study

In general, there are three components in the programme of study at the bachelor's degree level. They are: General Education, Professional Education, and Electives. Students at the Bachelor's Degree level must complete not less than 30 credits in General Education in four areas: Social Sciences, Humanities, Languages, and Science and Mathematics. General Education aims to broaden the students' knowledge and outlook; to understand oneself, others and the society as well as to understand nature; to be able to think critically; to have a good command of the language; to possess the desired characteristics suitable to the needs of the society and applicable to their daily life. General Education courses are usually offered in the first year of the programme of study.

Professional courses include Core Courses, Foundation Courses and Major Courses. They aim to equip students with knowledge, understanding, and to be able to work in their fields of study. The total number of professional courses at the Bachelor's Degree level is not less than 60 credits (in which not less than 30 credits are Major Courses and if any, not less than 15 credits are Minor Courses). Professional courses are usually offered from the second, third and fourth years of the programme of study.

Electives would give students the opportunity to choose any courses offered in the programme of study. It is required that students have Elective courses of not less than 6 credits. Elective courses are characterized by their supportive nature to widen the scope of each discipline.

5.3 Practical experience

In general, courses can be classified as theoretical courses and practice courses. Theoretical courses of one hour per week or 15 hours in one semester are equal to one credit. Laboratory

courses and practical courses of not less than 30 hours and 45 hours per semester are equal to one credit, respectively.

Suranaree University of Technology has utilized an academic administration system based on a multidisciplinary and integrative approach, a co-operative education principle (to ensure proper balance between theory and practice), team effort, and extensive use of technology for promoting academic quality and effectiveness. The University has determined that co-operative education be a part of the undergraduate curriculum - a major innovative development in Thai higher education. Students work as full-time employees at a work site during one term for at least 16 weeks. It is a joint effort between the work site, student and University as students learn to apply their knowledge in the workplace. Co-operative education students who complete the programme and pass evaluations receive 9 credits as well as a certificate from Suranaree University of Technology and the Thai Federation of Industries (Suranaree University of Technology, 2001: 41).

Assumption University, which is a private university, requires that Bachelor’s Degree graduates from the Faculty of Business Administration, participate in 16 sessions of the Seminar in Ethics for Businessmen. Also an additional 280 and 400 hours of training is required for students majoring in Business Computer and Hotel Management respectively (Assumption University, 2001: 28).

5.4 Grading and evaluation

Grading at higher education institutions is based on the course unit system/semester of credit. In most universities, course evaluation is done by grades and grade points as follows:

Grade	Meaning	Grade Point
A	Excellent	4.00
B+	Very Good	3.50
B	Good	3.00
C+	Fairly Good	2.50
C	Fair	2.00
D+	Poor	1.50
D	Very Poor	1.00
F	Failure	0.00
I	Incomplete	-
W	Withdrawn	-
WF	Withdrawn due to Failure	-
AU	Audit	-

Normally, a student must obtain at least 2.00 cumulative grade point average for a Diploma or a Bachelor’s Degree; and at least 3.00 cumulative grade point average for Graduate Diploma, Master’s Degree, Higher Graduate Diploma, and Doctoral Degree.

However, open universities: Sukhothai Thammathirat and Ramkhamhaeng University have their own grading system as follows:

Sukhothai Thammathirat	Per cent	Ramkhamhaeng	Grade
H – Honours	> 76 %	G – Good	4.00
S – Satisfactory	60 – 75 %	P – Pass	> 2.25
U – Unsatisfactory	< 60 %	F - Failure	< 2.25
I - Incomplete	-	-	-

6. ADMISSION REQUIREMENTS

Admission to higher education institutions is dependent on a candidate successfully passing the national university entrance examination. The general qualifications of students are:

- Having obtained a secondary school or grade 12 certificate or waiting for the result of secondary school education or its equivalent.
- Being physically and mentally sound.
- Having sufficient financial support for the duration of education.
- Not having been expelled from any higher education institution on grounds of misconduct.
- Being able to serve in any Thai government agency as assigned after graduation for those who complete courses in medicine and dentistry.

Qualified students who seek admission to higher education institutions under the national entrance examination must apply in person each year, and the application is usually held in April. Results are given at the end of May. Applicants have the right to apply to four different faculties at one or more universities of their choices. Those who have passed the written examination are then required to undergo an interview, physical examination and sometimes aptitude test as required by individual faculties.

In the selection and placement process, weights given to each achievement components are as follows:

- Scores from secondary school = 10%
(Cumulative Grade Point Average (GPA) from school grade 10-12 = 5%, and Percentile Rank (PR) of each applicant relative to fellow graduates from the same school = 5%)
- Scores in main subjects and in special subjects (if any) = 90%
(Examinations in main subjects and special subjects are available twice a year in October and March. Students receiving scores below the required minimum of any subject can re-apply for the next available examination on that subject. Scores of each student are valid for two academic years.)
- Interview/Physical examination = Pass/Fail

The quota system and university special programmes are also offered. Provincial universities and provincial campuses of Bangkok universities can use the quota system to fill 50 per cent of available places each academic year from all secondary schools in the campus region. The Faculties of Medicine at Chulalongkorn University, Mahidol University, Chiang Mai University, Khon Kaen University, and Prince of Songkla University, with the co-operation of the Ministry of Public Health, admit approximately 15 per cent of students through the Promotion of Medical Science Education for Rural Areas Project. A number of students are also admitted through university special programmes, such as the Development and Promotion of Science and Technology Talents Project, the Sports Promotion Programme and the Arts Promotion Programme.

Since there are limited places for students to enter public universities and institutes, there are two open universities: Ramkhamhaeng University and Sukhothai Thammathirat Open University, which offer higher education without entrance examination. Ramkhamhaeng University has provided greater access to higher education. Students with upper secondary school certificates (Grade 12) or Class 2 civil servants with lower secondary school certificates are admitted into bachelor's degree programmes in law, business administration, humanities, education, science, political science, and economics without any entrance examination. Sukhothai Thammathirat Open University is directed at upgrading the knowledge of persons who have work experience as well as providing an opportunity for secondary school graduates and their equivalent. Programmes of study offered are in the areas of education, management science, law, health sciences, economics, home economics, political science, liberal arts, communication arts, and agricultural extension and co-operatives. The qualifications of students to be accepted are quite varied: upper secondary school certificate (Grade 12) or the equivalent, lower secondary school certificate with five years work experience or those who have earned certificates or degrees and are already working in their profession, etc. While Ramkhamhaeng University, as an open-admission institution, still conducts lectures in campuses like a traditional university, Sukhothai Thammathirat Open University utilizes the distance-learning concept. The University employs correspondence media, radio broadcasts, television, audio and video and broadcast on demand, and other methods that enable students to study on their own without having to sit in a classroom.

Private universities and colleges also conduct their own examinations or selection for admission of students.

7. DEGREE CONFERRING AGENCIES

The degrees and diplomas graded by higher education institutions can be conferred by the individual institutions. In the case of graduates at the Bachelor's Degree level of public universities and institutes, each Faculty Board approves the list of graduates from that Faculty first, then submits it to the Dean's Council at the university level. The Dean's Council then presents the list of graduates in that academic year to the University Council for final approval of the award of degrees. For graduates of Master's and Doctoral Degree Programmes, the list of graduates would be first approved by the Faculty Graduate Committee and then by the Graduate School Committee. The list of graduates will then be submitted to the Dean's Council and the University Council, respectively, for approval.

Private universities and colleges can also confer degrees and diplomas at the institutional level.

8. ASSESSMENT OF HIGHER EDUCATION INSTITUTIONS

The Ministry of Education through the Commission on Higher Education is responsible for the assessment and accreditation of higher education institutions under its supervision. Public universities and institutions are less controlled or supervised than private higher education institutions. In setting up a new public university, the Ministry of Education proposes it to the cabinet for approval. If it is approved, it is notified to the Budget Bureau. The parliament has to approve the University Act. As for setting up a new faculty or a department of public universities, it can be approved by the Ministry of Education. Once the new public university, faculties and departments are approved, the quality of education depends much on that public university or institute. The curricula follow the standard regulations set by the Ministry of Education.

In the case of private higher education institutions, there is the Establishment Screening Committee to appraise the proposed project making sure that the administrative, physical, academic, staff and financial plans are all synchronized and feasible. Upon approval, it is sent to the Private higher Education Board. Recommendations from the Private Higher Education Board is submitted to the Minister of Education for endorsement and for his signature on the license. After obtaining the establishment license, each academic programme to be offered must be approved by the Ministry of Education. The requirements considered for the approval are divided into two parts: curriculum and readiness in curriculum management. As for programme accreditation, external examinations are applied to monitor the quality aspects of the programme. Every semester, an appointed External Examination Committee examines the test items of all subjects in each programme to make sure that they are relevant to the course outlines and that grading practices are of general standard. Approximately two years before the awarding of the degree, the institution has to submit an application for programme accreditation. The requirements considered are along the same bases as those of the application for approval of academic programmes. The Committee of experts in the specialization appraises the on-going programme against the proposed plan along with inputs from the External Examination Committee, interviews of staff and students, and a site visit. The Committee then recommends approval to the Board. Finally, programmes are accredited by the Minister with the recommendation for approval by the Private Higher Education Board (Chantavit,1995: 2-5).

The 1999 National Education Act specifies that there shall be a system of educational quality assurance to ensure the improvement of educational quality and standards at all levels. Such a system shall be comprised of both internal and external quality assurance. Internal quality assurance is regarded as a part of educational administration which must be on a continuous process. Higher education institutions are required to prepare annual reports to be submitted to parent organizations, agencies concerned and made available to the public for purposes of improving educational quality and standards and external quality assurance. The Office of Education Standards and Evaluation was established in November, 2000 as a public organization, responsible for the development of criteria and methods of external evaluation, conducting evaluation of educational achievements in order to assess the quality of institutions. All educational institutions including higher education institutions receives external quality evaluation at least once every five years from the last exercise and the results of the evaluation submitted to the relevant agencies and made available to the general public.

9. DEGREES AND PROFESSIONAL COMPETENCE

In the medical profession, graduates from public universities need not take the Medical Council Test in order to obtain a license to practice; they just apply for the license with a letter certifying that they successfully completed all the requirements for the Degree of Doctor of Medicine from their faculty. However, graduates from private universities have to take the Medical Council Test like graduates from abroad. As for the law profession, graduates both from public and private higher education institutions need to take a test in order to obtain a license to practice law. In the case of engineering, graduates from both public and private higher education institutions need not take any test in order to enter their profession. However, the Engineering Council has to approve every curriculum in engineering.

10. INTERNATIONAL RECOGNITION OF DEGREES

Thailand is a signatory of the UNESCO Regional Convention on the Recognition of Studies, Diplomas and Degrees in Higher Education in Asia and the Pacific which was held in Bangkok, Thailand on December 12-16, 1983. However, the Thai parliament has not yet ratified this agreement. In April 1998, Thailand entered into a bilateral agreement with Australia on recognition of degrees and diplomas.

REFERENCES

- Assumption University, 2001. *Graduate – Undergraduate Bulletin 2001-2002*. Bangkok : Assumption University.
- Chantavit Sujatanond, 1995. *Mechanisms in the Supervision of Private Higher Education in Thailand*, Bangkok: Bureau of Private Higher Education, Office of the Permanent Secretary for University Affairs).
- Ministry of University Affairs, 2000. *Compendium of Programmes, Fields of Study, and Degree, Awarded by State Institutions of Higher Education*. Bangkok: Chaupim Printing House Ltd.
- Ministry of University Affairs, 2003. *Regulations Concerning Admission to Higher Education Institutions Academic Year 2003*. Bangkok: Ministry of University Affairs.
- Ministry of University Affairs, 2000. *Thai Higher Education in Brief*. Bangkok : Pra Cha Chon Co., Ltd.
- Office of the National Education Commission, 2002. *Education in Thailand 2002/2003*. Bangkok: Amarin Printing and Publishing Public Company Limited.
- Office of the Prime Minister, 2000. *Thailand into the 2000's*. Bangkok: Amarin Printing and Publishing Public Company Limited.
- Prince of Songkla University, 1992. *Prince of Songkla University Bulletin 1992*. Songkla: Prince of Songkla University.
- Suranaree University of Technology. 2001. *Annual Report 2001*. Nakhorn Ratchasima: Suranaree University of Technology.
- Varaporn Bovornsiri, 1998. *Thai Education Development During 1946-1996: Higher Education*. Bangkok: Department of Higher Education, Chulalongkorn University.
- Commission on Higher Education*. Available at <http://www.inter.mua.go.th>
- Distance Education Services*. Available at <http://www.stou.ac.th/Eng/>
- National Education Act of B.E. 2542 (1999)*. Available at <http://www.moe.go.th/English/edu-act.htm>

New Administrative Structure of the Ministry of Education. Available at http://www.moe.go.th/English/new_administrative.htm

Pathumwan Institute of Technology. Available at <http://wada.ptwit.ac.th>

Thai Economic Performance in Q4 and Economic Outlook for 2003. (Press Release on 17 March 2003). Available at <http://www.nesdb.go.th>

Thai Higher Education in Brief. Available at <http://www.inter.mua.go.th>

1. COUNTRY PROFILE

Vietnam is situated on the east of the Indochinese Peninsula, sharing borders with China to the north, and with Laos and Cambodia to the west. With an area of 332,000 square kilometres, Vietnam is well endowed with natural resources, sizable forests, and reserves of coal, petroleum and hydro-electric potential.

Vietnam has a population of approximately 79.7 million (2002), about 70 per cent of which live in rural areas. The population growth rate is about 1.3 per cent per annum. It has 53 ethnic groups but about 87 per cent of the total population of Vietnam are Ethnic Vietnamese (Kinh) and the Vietnamese language is the state language. Popular foreign languages are English, French, Chinese and Russian.

With a per capita income estimate of approximately US\$440 in 2002, Vietnam remains among the poorest countries. The 30-year war, which ended in 1975, caused heavy difficulties for Vietnam. After reunification in 1975, Vietnam first pursued development as a centralized planned economy. The country was in its worst stage of socio-economic crisis: production stood still, inflation skyrocketed, the country was in an economic blockade, and people's lives were extremely hard. The American embargo made these difficulties more serious.

In 1986 the Government has adopted a policy of transition from the centralized planned economy to the market economy, known as 'Doi Moi' (renewal). After a decade of persistent efforts to implement the renewal policy, Vietnam achieved very important successes in socio-economic development, in politics, and in internal and external relations. The socio-economic crisis was partially eased. For the last ten years the growth of GDP has been kept up as follows:

1992	1993	1994	1995	1996	1997	1998	1999	2000	2001	2002
8.70	8.08	8.83	9.54	9.34	8.15	5.76	4.77	6.79	6.89	7.04

According to the national development plan, the goals of industrialization and modernization are to turn Vietnam into an industrialized country with a modern material-technical base, an appropriate economic structure, advanced production relations suited to the development level of the productive force, high material and spiritual life, and firm national defence and security. The common national aim of Vietnam is *a rich people, a strong country, and an equitable, democratic and civilized society.*

2. NATIONAL EDUCATION SYSTEM

According to the Education Law, adopted by the National Assembly, December 1998, the national education system of Vietnam consists of four sub-systems: Pre-school Education, General Education, Vocational-professional Education, Higher Education with the structure 5-4-3-4 (Figure 1):

- Pre-school education carries out the nurturing, caring and education of children between 3 months to 6 years of age;
- General education consists of: (1) Primary education which is the compulsory education level for all children between 6 to 14 years of age; (2) Lower secondary education which is conducted in four years of schooling, from the 6th to 9th grade; (3) Upper secondary education which is conducted in three years of schooling, from the 10th to 12th grade.
- Vocational-professional education consists of: 1) Professional secondary education which is conducted over three to four years of study for those with lower secondary education diploma; or one to two years of study for those with upper secondary education diploma; 2) Vocational training which is given to those with educational capacity and health suited to the trade to be learned, and conducted in less than one year in short-term and from one to three years in long-term vocational programmes.
- Higher education includes undergraduate education and postgraduate education.

The modes of education are formal education and non-formal education. Some important statistics about the status of education (academic year 2002-2003):

- Literacy rate 94 per cent;
- Primary education is compulsory (from the year 2000);
- Total number of students for all levels of education is nearly 22 million;
- The average number of school years for the population is about 7.3.

3. HIGHER EDUCATION SYSTEM

3.1 Higher Education Institutions

The Ancient Higher Education (H.E.) system was established in Vietnam in the 11th century with Quoc Tu Giám (Royal School). But the modern H.E. system does not have a long history of development. In 1902 a secondary professional medical school was established in Hanoi by French colonists to train nurses for the entire Indochina Peninsula, but it was only at the beginning of 1940s that a complete university was founded there.

Since the August Revolution of 1945, and especially after the victory of the war against the French in 1954, the number of colleges and universities has increased dramatically in both North and South Vietnam. Since 1975 all colleges and universities in Vietnam have been united under one system.

Until 1993 Vietnam did not have large multi-disciplinary universities. There were only small colleges grouped according to their specializations and some comprehensive universities that

offered programmes in the humanities, social and natural sciences. The monodisciplinary institutions, inherited from the Soviet models, hampered the tendency of training on a wider spectrum and the capacity to link research with social service in a comprehensive way.

Starting at the end of 1993, a number of leading H.E. institutions, which formed the core of the overall system, were established consisting of:

Figure! VIETNAM NATIONAL EDUCATION SYSTEM

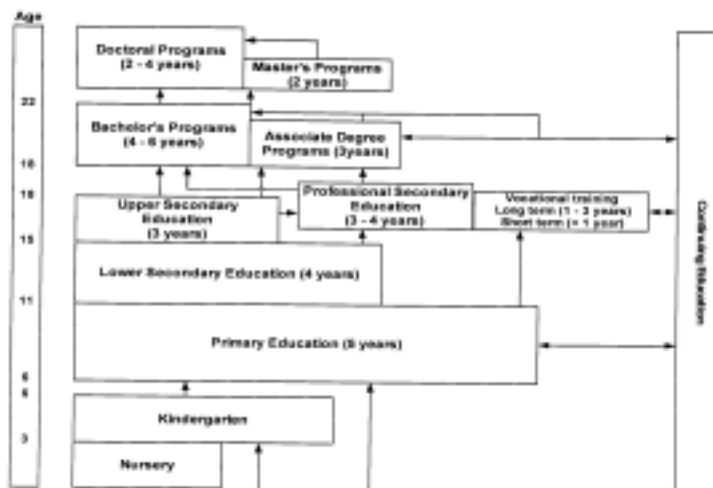

- multi-disciplinary universities (Hanoi National University - founded in December 1993; Ho Chi Minh National University - January, 1995; Hue, Danang, Thainguyen Universities - April, 1994);
- open universities (Semi-public Open University of Ho Chi Minh City - July 1993, Hanoi Open University - November 1993),
- a number of newly established people-founded (private) universities and colleges (17 institutions are already in operation), and
- a number of community colleges.

According to 2002-2003 statistical data, there are in Vietnam 202 H. E. institutions (179 public, 6 semi-public, 17 private, not including the system of the military and security H. E. institutions). H.E. institutions have been distributed in some main cities and provinces such as Hanoi, Ho Chi Minh City, Hue, Haiphong, Danang, Thainguyen, and Cantho.

The total student number of all delivery modes is 1,045,382; the total number of academic staff is 38,608, in which 40 per cent are female, 4 per cent are associate and full professors and 14 per cent are doctoral degree holders.

Besides H.E. institutions, there is in Vietnam a system of research institutes which belong to the Centre for Science and Technology and the Centre for Humanities and Social Sciences and to some ministries. According to the Law of Education and related regulations, many of those research institutes are eligible to offer master programmes with the co-operation of H.E. institutions and to offer doctoral programmes independently.

3.2. Governance and administration in the H.E. system

According to the Education Law, H.E. institutions are autonomous and accountable as defined by legislation and by their charters in following aspects: (1) Development of curriculum, teaching manuals, teaching and learning plans for training fields assigned; (2) Organization of admission according to quotas given from the Ministry of Education and Training, organisation of training processes, confirmation of graduates and issuance of degrees or diploma; (3) Organization of institution's own structure; (4) Mobilisation, management and use of resources for the realization of educational aims; (5) Co-operation with domestic and international economic, educational, cultural, sports, athletics, medical, research organizations in compliance with governmental regulations.

At present the management of the H.E. system has been stipulated as follows. At the national level, the MOET manages about 30 important H. E. institutions directly (allocating the budget and making decisions regarding personnel and functions). Hanoi and Ho Chi Minh City National Universities are given higher level of autonomy. Other ministries supervise some mono-disciplinary institutions related to their areas. The provincial authorities govern the junior colleges located in their territories. However, all of the institutions are under the management of MOET in terms of academic concerns, despite the fact that they are under the direct supervision of provinces or other ministries. This means that MOET promulgates and manages admission regulations, defines the curriculum framework, including structure and content of subjects, training duration, proportion of time between basic and specialised subjects, between theory practice and practicum. H.E. institutions design curricula for their teaching programmes based on the curriculum framework.

The media for teaching at H.E. institutions is Vietnamese, except in some special subjects.

At the institutional level, a general regulation on the organization and activities for H.E. institutions has been promulgated by the decision 153/2003/Q-TTg of the Prime Minister in July 2003.

According to the general regulation, in an H.E. institution there is an Institutional Council which has the following responsibilities: (1) setting up the mission, goals and strategic plans for the institution; (2) building specific regulations and rules for all activities in the institution; (3) approving important expenditure and investment projects of the institution; (and 4) supervising the implementation of democratisation in the institution.

The rector/president is the legal representative of the institution and is responsible for the direct management of all institution activities in compliance with institutional regulations in particular and with legislation in general. The rector/president is appointed on a 5-year term by the minister after a survey of staff opinion.

The rector/president organizes appropriate mechanisms for the management of the institution. The Education and Research Advisory Council is one of the most important organization which helps the rector/president in academic affairs. In the institution, there are different academic departments, research institutes, service centres, etc.

As mentioned above, two national universities have higher autonomy - they receive public funds directly from the Government (from the Ministry of Finance), their presidents are appointed by the Prime Minister, they have the right to design curricula for new majors and confer degrees of all levels from bachelor's to doctor's degrees.

4. CHARACTERISTICS OF DEGREES AND DIPLOMAS

4.1 Types of degrees and diplomas

According to the Education Law, these are the degrees and diplomas for H.E. system (Figure 1):

- Associate degree (*bang “cao dang”*) is awarded to those who complete short-term H.E programmes (3 years) in junior colleges;
- Bachelor’s degree (*bang “cu nhân”*) is awarded to those who complete long-term H.E programmemes (4-6 years) in universities and senior colleges;
- Master’s degree (*bang “thac si*) is awarded to those who complete graduate Master’s programmes (with or without a thesis) which last for 2 years (for bachelor’s degree holders);
- Doctoral degree (*bang “tien si”*) is awarded to those who complete graduate doctoral programmes (with a thesis) which last for 2 years (for master’s degree holders) or 4 years (for holders of bachelor’s degree with honours).

Besides, for the field of medicine, there are some advanced professional diplomas as follows: (1) Hospital Internship (about 3 years for bachelor of medicine holders); (2) Specialisation of first level (about 5 years for bachelor of medicine holders); (3) Specialisation of second level (about 2 years for those who have worked at least 3 years after receiving first level specialization diplomas).

4.2 Title and abbreviation of the degrees and diplomas

- For the bachelor’s degree, the following titles are used. The title *cu nhân* (bachelor) is used for the fields of study: natural and social sciences, humanities, pedagogy, law and economics. The titles *ky su* (engineer); *kien trúc su* (architect), *bác sĩ y khoa* (medical doctor), *đouc sĩ* (pharmacist) are used for the fields of study engineering, architecture, medicine, and pharmacy, respectively. For the rest there are not special titles, but called: *tot nghiệp đại học* (university graduates) in some fields of study. There are no specific abbreviations for titles of bachelor degrees.
- For the master’s degree, a common title *thac si* is used, and the field of study follows. The abbreviation for *thac si* is *Th.S*.
- For doctoral degree, a common title *tien si* is used, and the field of study will be followed. The abbreviation for *tien si* is *T.S*.

In the past, there were two levels of doctoral degree in Vietnamese education system, but according to the Education Law (1998) there is officially only one level at present. However, for those who have earned the doctor’s degree of second level before in Vietnam or abroad (for instance in Russia and some East European countries) the title *tien si khoa hoc* (Doctor of Science) with abbreviation *TSKH* is used.

4.3 Information contained in the degree document

A degree document consists of: recipient's name in full and date of birth, title of degree, major (field of study), delivery mode and serial number of the document, awarding institution, name and signature of the institution president/rector.

To any degree document is attached a transcript of records with numbers of credits and grades.

At present, only two national universities issue models for degree documents by themselves, and all other H.E. institutions use common models issued by the MOET.

5. STUDY PROGRAMMES OFFERED BY SINGAPORE UNIVERSITIES

5.1. Number of credits

The H.E. system has the main study programmes leading to degrees as follows (Figure 1):

- *The short-term study programme:* This programme admits winners of the university entrance examination and lasts for 3 years. At present, the short-term study programme is being carried out by junior colleges (teachers' and non-teachers'), and by some universities, as additional programmes.
- *The long-term study programme:* This programme admits winners of the university entrance examination and lasts for 6 years for students of medical and dental sciences, 5 years for students of engineering; and 4 years for students at the majority of other institutions.
- *The master's programme:* This programme admits graduates of the long-term H. E. study programmes and lasts for 2 years (full-time) or 3 years (part-time). The structure and minimum workload for the master's degrees curricula are shown in the Table 2.
- *The doctorate programme:* Students admitted as candidates of a doctorate programme are from two sources: the bachelor's degree holders with excellence, and master degree holders. Students of the first group have to complete courses for master's degrees shown in Table 2. In addition, students of both groups have to complete courses on specialized disciplines with a workload of 5-10 credits. The most important requirement for the doctor's degree is that the student has to defend a substantial thesis representing his/her original research.

The structure and minimum workload for different types of undergraduate curricula are prescribed in the Table 1 (according to the Decision 2677/GD&DT, 1993), and for master's and doctor's degrees curricula shown in Table 2 (according to the Decision 18/2000/QD-BGD&DT, 2000). The term "credit" is defined as follows: one unit of credit is equal to 15 hours of lecture class or 30-45 hours of practice or experimentation in laboratories or 45-90 hours on-the-job apprenticeship. At present, due to a shortage of learning materials and to the passive methods of teaching, for one hour of lecture, the student always uses only less than one hour for individual preparation, while in other developed countries one hour of lecture needs two hours of individual preparation. For this reason one credit in Vietnam is equal only to 2/3 credit in some countries, and the workload for a week in Vietnam is about 30 hours.

Table1. Structure and minimum workload for undergraduate programmes

Types of Degree	Types of Programmes	Total work-load	Work-load for G.E.	Professional Education				
				Total	Care	Major	Minor	Thesis
Diploma or Associate Degree	2-year technical programmes	120	30	90		45		
	3-year technical programmes	180	30	150		45	25	
	2-year professional programmes	120	50	70		45		
	3-year professional programmes	160	50-90	70-110		45	25	
	Short-term teacher training programmes (3 years)	160	90	70	45			
Bachelor's Degree	4-year study programmes	210	90	120		45	25	10
	5-year study programmes	270	90	180		45	25	15
	6-year study programmes	320	90	230		45	25	15
	Long-term teacher training programmes (4 years)	210	90	120	45	45	25	5

Table 2. Structure and minimum workload for the Master's degree curricula

Programmes leading to Master's degree	Total workload (number of credits)	Courses (per cent)		Thesis (per cent)
		Philosophy and Foreign Language	Basic and Specialized	
Type 1 (practice oriented)	80-100	20	65-70	10-15
Type 2 (research oriented)	80-100	20	50-55	25-30

5.2 Sequence of the study

The academic year of the H.E. institutions in Vietnam has often been divided into two semesters: the first semester normally starts in the middle of September and ends in the middle of January, the second semester usually starts in the middle of February and ends in the beginning of June.

For the majority of H.E. institutions in Vietnam the delivery process is organized by a mixed annual and credit system. That means: study contents are divided into small subjects, measured by credits, and student achievement is assessed by the accumulation of subjects. However, students are not given enough opportunities to choose their own appropriate sets of subjects, so students of each major are often sitted in a class all together. From 1993-94 academic years some H. E. institutions (such as Ho Chi Minh City University of Technology, Dalat University, Cantho University) have applied a credit system similar to that of the U.S.A. At present, about ten H.E. institutions have applied the credit system, and this number is increasing. Now the Government encourages H.E. institutions to apply the credit system to their delivery process.

For programmes leading to bachelor's degrees the total workload is divided into two components: general education and professional education, as showed on the Table1. In most H.E. institutions, the general education component is largely provided in the first two years. At the end of the professional education stage, students have to complete a thesis or to sit for some final examinations.

There are two types of programmes leading to master degrees: practice-oriented and research-oriented programmes. For the research oriented programme more attention is paid to the thesis, but for the practice-oriented programme more attention is paid to the course work.

For programmes leading to doctoral degree the thesis is the most important component.

5.3 Grading and evaluation

For every subject, students are required to pass an examination. Student achievement for each semester or at the end of a programme is evaluated for all accumulated subjects through an average score weighted by the number of credits in each subject, as shown in the following formula:

$$S = \frac{\sum_{i=1}^N n_i a_i}{\sum_{i=1}^N n_i}$$

where:

S = average score,

a_i = the score for the i-subject,

n_i = the number of credits for the i-subject,

N = the total number of accumulated subjects.

5.2 Sequence of the study

The academic year of the H.E. institutions in Vietnam has often been divided into two semesters: the first semester normally starts in the middle of September and ends in the middle of January, the second semester usually starts in the middle of February and ends in the beginning of June.

For the majority of H.E. institutions in Vietnam the delivery process is organized by a mixed annual and credit system. That means: study contents are divided into small subjects, measured by credits, and student achievement is assessed by the accumulation of subjects. However, students are not given enough opportunities to choose their own appropriate sets of subjects, so students of each major are often sitted in a class all together. From 1993-94 academic years some H. E. institutions (such as Ho Chi Minh City University of Technology, Dalat University, Cantho University) have applied a credit system similar to that of the U.S.A. At present, about ten H.E. institutions have applied the credit system, and this number is increasing. Now the Government encourages H.E. institutions to apply the credit system to their delivery process.

For programmes leading to bachelor's degrees the total workload is divided into two components: general education and professional education, as showed on the Table1. In most H.E. institutions, the general education component is largely provided in the first two years. At the end of the professional education stage, students have to complete a thesis or to sit for some final examinations.

There are two types of programmes leading to master degrees: practice-oriented and research-oriented programmes. For the research oriented programme more attention is paid to the thesis, but for the practice-oriented programme more attention is paid to the course work.

For programmes leading to doctoral degree the thesis is the most important component.

5.3 Grading and evaluation

For every subject, students are required to pass an examination. Student achievement for each semester or at the end of a programme is evaluated for all accumulated subjects through an average score weighted by the number of credits in each subject, as shown in the following formula:

$$S = \frac{\sum_{i=1}^N n_i a_i}{\sum_{i=1}^N n_i}$$

where:

S = average score,

a_i = the score for the i -subject,

n_i = the number of credits for the i -subject,

N = the total number of accumulated subjects.

In most H.E. institutions, subject evaluation is done by grade points in the scale from 0 to 10, in which the pass score is 5, the maximum score is 10 and the range of scores for “honours” is from 9 to 10. In some institutions, especially where the credit system is used, a letter grade scale is used at the same time: A (excellent), B (good), C (pass) and F (Fail).

6. ADMISSION REQUIREMENTS

In order to take part in university entrance examinations the upper secondary students have to succeed in the national high school leaving examination. There have been many changes in the procedures of student admission in recent years. By 1987 the entrance examinations for all H.E. institutions was administered by the MOET, then from 1988 the organisation of entrance examinations was given to each institution, but from 2002 MOET got back in charge of the organisation of entrance examinations for all H.E. institutions.

Students are required to take examinations before being admitted to H.E. institutions, except students who were winners of international or national “olympic” examinations. The prerequisites for the entrance examination for the full-time students are as follows:

- Graduated from general or technical-vocational secondary education.
- Under 32 years of age with good health.

For the part-time and open admissions the latter is not necessary. The entrance examination is divided into 4 groups according to the fields of study chosen by students. The subjects of the examination for group A include mathematics, physics and chemistry; for group B: mathematics, chemistry and biology; for group C: literature, history and geography and for group D: literature, mathematics and a foreign languages.

So far, high school leaving examinations and university entrance examinations are organised separately, and examination questions are given mostly in essay tests. However, MOET is planning to combine high school leaving and university entrance examinations into a single

examination and use mainly standardized objective tests from 2005. The Office for Assessment and for Accreditation has been established in the MOET in July 2003 responsible for organising all national examinations and co-ordinating quality assurance activities in the H.E. system.

Graduate (master's and doctoral) programmes admit students who are holders of the appropriate previous degrees and pass an entrance examination. The exemption of examination is provided for the holders of the appropriate previous degrees with honours.

7. DEGREE CONFERRING AGENCIES

According to the Education Law following regulations have been given for conferring H.E. degrees:

- For associate, bachelor's and master's levels: the institutions authorised to conduct training at these levels will confer diplomas for the appropriate levels.
- For the doctoral level: the Minister of Education and Training and presidents of two national universities confer doctoral degrees.

8. ASSESSMENT OF HIGHER EDUCATION INSTITUTIONS

Currently, MOET has given standards for all study programmes and regulations for carrying out these programmes at all H.E. institutions, and formally MOET controls the implementation of the programmes.

To implement autonomy and accountability of H.E. institutions, as defined in the Law of Education, a quality assurance system is being organized for the H.E. system in Vietnam. An office has been established in the MOET as mentioned above for co-ordinating accreditation activities in the near future.

9. DEGREES AND PROFESSIONAL COMPETENCE

In Vietnam at present, there has not been any professional association which has the right to give licences to practice in most professions. However, for the area of medicine, the Ministry of Health gives the right to carry out independent professional activities for a doctor of medicine or a pharmacist only if he/she has worked at least 5 years in a public medical organization.

10. INTERNATIONAL RECOGNITION OF DEGREES

Vietnam is a signatory of the UNESCO Regional Convention on the Recognition of Studies, Diplomas and Degrees in H.E. in Asia and the Pacific. However, so far it has not been ratified yet.

Practically almost all undergraduate and graduate degrees from developed countries and from some countries, which have long relationships with Vietnam, have been recognised. At present many twinning programmes and sandwich programmes have been established at several universities in Vietnam. According to those programmes, overseas universities recognize credits earned at Vietnamese counterparts and allow students to continue learning in overseas universities, and in the end degrees will be awarded by overseas universities. To implement those programmes Vietnamese and overseas universities must sign some agreement on major requirements for study curricula.

Some Vietnamese universities have participated in regional activities in the direction of registration and reciprocity for some professions, for example APEC Engineering Project, Architectural Registration in Western Pacific Region. Vietnam has enthusiastically participated in activities organized by the SEAMEO Regional Institute of Higher Education Development for promoting the quality assurance system within universities in the South-East Asia region.

REFERENCES

Economy of Vietnam and the World 2002-2003, Vietnam Economic Times, January, Hanoi, 2003.

Resolution of the 2nd meeting of the Vietnam Communist Party Central Committee on Strategic Orientations in Education and Training for the Industrialization and Modernization Period and Tasks until the Year 2000. National Political Publishing House, Hanoi, 1997.

Education Law of the S.R.. Vietnam, Hanoi, 1999.

The Vietnam Yearly Education-Training Directory 2003, Statistics Publisher, Hanoi, 2003.



B. Appendixes

• France • Germany • United Kingdom • United States of America

1. THE FRENCH HIGHER EDUCATION SYSTEM ¹

Higher education in France is characterized by a variety of institutions; it is provided in universities open to a large number of students, in “grandes écoles” and other professional higher education institutions with highly selective admission policies, and in post-secondary classes in some upper secondary schools (lycées). Whereas most institutions come under the responsibility of the Ministry of Youth, education and Research, some grandes écoles and other specialised schools of higher education come under other ministries.²

Universities are made up of training and research units (UFR)³, offering curricula in academic fields and of various institutes and schools, such as the engineering schools, the university institutes of technology (IUT)⁴, offering courses in engineering, technology and management), the university vocational institutes (IUP)⁵ which offer technological courses and practical training, the teachers training colleges (IUFM)⁶ which offer training courses for primary and secondary school teachers. This variety of institutions within the universities expresses a move towards more “professionalization” in the last 40 years in order to correspond to the economy’s and students’ needs.

The grandes écoles offer a high standard of professional education, mostly in three years after two years of preparatory classes, for a very selective competitive entrance examination. Both public and private grandes écoles provide education for the future leaders of administration, technology, and business. They differ widely in the fields of study covered (some are highly specialized), the time needed to complete the study programmes, and the difficulty of the admission procedure and requirements.⁷

The Conservatoire national des arts et métiers (CNAM) in Paris, with its regional centres, gives to adults engaged in professional life the possibility to follow courses in their spare time without previously earned diplomas. Courses cover primarily the technical and the business fields. By means of a system of sequential diplomas, students may prepare degrees leading up to the engineer diploma. Course programmes in the CNAM take much longer to complete than full-time courses in other institutions.

¹ This description has no official character as far as the French educational authorities are concerned.

² the present legislation is the 1984 Higher Education Law which has granted universities administrative, pedagogical, research and financial autonomy.

³ UFR : unités de formation et de recherche

⁴ IUT : Instituts Universitaires de technologie

⁵ IUP : Instituts Universitaires Professionnalisés

⁶ IUFM : Instituts Universitaires de Formation des Maîtres

⁷ 91 universities, including 112 IUT, 90 engineering schools, 258 IUP and 30 IUFM

85 public engineering schools, independent from the universities, 68 private engineering schools

234 business, management and accounting schools

19 private higher education institutions, including five catholic Institutes (universities)

23 architecture schools

229 art and culture schools

420 paramedical schools outside of universities

133 schools of social work

216 other schools preparing to a variety of professions

In upper secondary schools (lycées) there are post-secondary classes: 2,100 higher technician divisions (STS)¹ in technical lycées, and 485 preparatory classes for the grandes écoles (CPGE)²,

In the academic year 2002-2003, there were 2,164,761 students enrolled in higher education³. Of these:

- 1.3 million were enrolled in universities,
- 89,062 in teacher training colleges (IUFM);
- 115,465 in university institutes of technology (IUT) linked to universities: 48,579 in secondary sector specializations, and 66,886 in tertiary sector specializations.
- 95,430 in engineering schools;
- 245,186 in higher technician divisions (STS) in technical lycées;
- 72,015 in preparatory classes for the grandes écoles in lycées (CPGE),

University students enrollment:

	1st cycle	2nd cycle	3rd cycle	Total
Law - Political Sciences	90,604	63,281	30,701	184,586
Economics, Business	37,209	44,822	22,566	104,597
Economic and Social Administration	33,277	19,721	540	53,538
Letters, Language Sciences, Arts	66,566	44,239	11,589	122,394
Languages	81,722	52,887	6,017	140,626
Human and Social Sciences	103,007	95,723	32,047	230,777
Sciences and Materials Structure	66,414	31,498	12,763	110,675
Science and Technology/Engineering	13,121	57,461	15,856	86,438
Natural and Life Sciences	40,447	30,794	15,355	86,596
Sciences and Techniques in Physical and Sports Education (STAPS)	26,059	15,996	822	42,877
Health Sciences	47,894	27,821	63,409	139,124

2. THE FRANCE HIGHER EDUCATION SYSTEM WITHIN THE EUROPEAN AREA OF HIGHER EDUCATION

The present evolution is dominated by the European “Bologna agreement” (June 1999), initiated by the “Sorbonne declaration” (25/5/1998). This declaration stressed universities’ central role in developing European culture. Adopted by the United Kingdom, France, Germany, and Italy, it promoted the creation of a “European area of higher education” as a key to citizen mobility and employability. Other European countries were invited to join in this effort. It set the stage for a widespread consultation that was to result in the Bologna agreement.

It is based on the fundamental principles of university independence and autonomy and aims at increasing the international competitiveness of the European system of higher education. The countries agreed to work together:

- to develop a “common architecture” of qualifications and courses by making study programmes and degree courses more transparent and comparable at international level, by adopting a system of harmonization/comparability for university degrees.
- to adopt a system of two main cycles - undergraduate and graduate.
- to establish an international credit-based system, the “European Credit Transfer System” (ECTS), in order to promote widespread student mobility and improve access to training opportunities. In order to ease mobility, courses will be increasingly organised in semesters.

302 ⁸ STS: sections de techniciens supérieurs

⁹ CPGE: classes préparatoires aux grandes écoles

¹⁰ Reference: *Repères et références statistiques sur les enseignements, la formation et la recherche – RERS - (statistical yearbook; Education, training and research. Ministry of Education, 2002.*

- to increase the European dimension in education and training and the number of cooperation projects of integrated study programmes, using the joint programme “Socrates” and its sub-programme “Erasmus” for students exchanges, managed by the European commission.

The Declaration aims at some degree of overall convergence and unification harmonizing the parallel developments of the different European higher education systems, but not at standardization or “uniformisation”. It respects the diversity of institutions and the principle of autonomy. This was a commitment by 29 countries, facing their common challenges related to the growth and diversification of higher education, the need to increase the employability of graduates, the shortage of skills in key areas, the expansion of private and transnational education.

They committed themselves to re-form the structures of their higher education systems in a convergent way, to engage in coordinating their policies of European higher education and in an action programme, with deadlines and a set of specified objectives:

- the adoption of a common framework of readable and comparable degrees, also through the implementation of a descriptive appendix to the diploma, called the “diploma supplement”;
- the introduction of undergraduate and postgraduate levels in all countries, with first degrees in three years and relevant to the labour market;
- the adoption of a compatible credit system also covering lifelong learning activities. This common system conducts France to integrate all its diversified paths of studies and intermediary degrees within a new overall Licence/Master/Doctorate (LMD) degree framework (respectively, 3/5/8 academic years), on a basis of 30 credits (corresponding to an agreed volume of work, under various forms) per semester and 60 credits per academic year;
- the acquisition of a worldwide degree of attractiveness “equal to Europe’s cultural and scientific traditions”;
- a European dimension in quality assurance, with comparable criteria and methods;
- the elimination of remaining obstacles to the free mobility of students (as well as trainees and graduates) and teachers (as well as researchers and higher education administrators).

Signatory countries are considering planning legislative reforms for convergence in the different areas and constituent sub-sectors of their higher education systems: shorter studies, two-tier degree structures, credit systems, external evaluation, more autonomy coupled with more accountability.

In accordance with the Bologna process, a new university grade, the Master, has been introduced in the French system¹¹, in order to award the same title to students obtaining different diplomas after five years of post-baccalaureate study, so that their qualifications can be more readily interpreted in other countries. The Master’s degree, with a vocational or a research orientation, has been designed to cover all higher education institutions in France, including universities and “grandes écoles”, irrespective of which institution and which ministry is responsible.

¹¹ Decree 99-747 - 30/8/1999

The Master's degree is conferred on graduates of existing national diplomas at the level bac + 5 years (DEA, DESS, engineering diplomas) or bearers of equivalent diplomas and qualifications stipulated by ministerial decree. It does not replace existing degrees and qualifications which remain in place. The Master's degree can also be conferred in cases where qualifications have been obtained through an official recognition or validation of studies, professional or personal knowledge and periods of study or training in a European country.

Universities and grandes écoles are thus offered the same qualification within a joint reference system. The intention is to preserve the identity of the different components that make up the French system of higher education, at the same time increasing its "visibility" and transparency, to open up new perspectives for mobility and integration of French students and to make French institutions, education and training courses and qualifications more attractive to foreign students.

Admission to higher education

After twelve years of primary and secondary school education (more in case of repetition of one or more years), a student will earn the secondary school leaving certificate, the baccalauréat (baccalauréat or "bac") certifying the successful completion of these studies. This diploma entitles him/her simultaneously to enter higher education. Students can choose among several baccalauréat types (corresponding to specializations during their two last years in secondary schools):

- General baccalauréats: L (literary studies), ES (economic and social studies), and S (scientific studies).
- Technological baccalauréats: STI (industrial sciences and technologies), STL (laboratory sciences and technologies), SMS (medical and social sciences), STT (tertiary sciences and technologies).
- Vocational baccalauréats (baccalauréat professionnel): about 70 specializations.

Each baccalauréat holder is in principle free to select a field of study. In order to increase the students' level of information and allow them to make their choices more adequately, orientation and guidance services and staff have improved in the universities. High school leavers and new students are advised with regard to the best combination of types of baccalauréat and higher education study choices. Bac S holders have the widest range of possibilities in most fields for further study. Holders of other types of baccalauréat have a more limited choice of further studies (because of special additional rules for admission, mostly in the non-university sector, or because of lacking prerequisites, due to their secondary level specializations, for some types of studies).

Admission to the various levels of post-baccalauréat education, including university admission is not restricted in principle to baccalauréat holders. It may also be granted upon:

- recognition of an agreed equivalent diploma.
- receipt of a special diploma giving access to university without the baccalauréat (DAEU)¹². The DAEU has two options, humanities and sciences. It is delivered by universities for candidates whose studies have been interrupted for at least two years. The diploma is delivered after a one-year course and a written and oral examination, which evaluates general knowledge and culture and also candidates' methods and know-how as needed in higher education. This DAEU gives the same rights for admission in a university as the baccalauréat.

304 ¹² DAEU : *diplôme d'accès aux études universitaires. This is a national diploma of higher education created in 1994, which replaces the former special entrance examination for university (ESEU).*

- validation of professional and personal experience. Present regulations¹³ organize the possibility to validate studies, personal work and professional experience as equivalents to diplomas required for access to the preparation for a national diploma, or as part of the examinations required for this diploma. In 2001, about 16,000 such validations of professional experience have been granted by the universities and the CNAM. Holders of foreign titles or diplomas may ask for validation. The decision to validate qualifications is taken by the president of the university or the head of the institution on the proposal of a pedagogical commission.

Law schools in universities prepare also for a two-year law course open to candidates without the baccalauréat, above the age of 17, leading to the national diploma “Capacité en droit”.

Some institutions and fields within universities are entitled to add conditions to the baccalauréat before granting admission. Admission to most short cycle vocational courses (university institutes of technology) is based upon school records and interviews. Other short-cycle post-secondary courses in technology upper secondary schools (STS) require a corresponding type of baccalauréat. There are more applications than places available; a selection takes place on the basis of previous performance (portfolio), sometimes combined with an interview.

In the case of medical studies, admission to the first year is not limited. However, a very rigorous selection occurs after the first year of the first cycle in medical studies (PCEM)¹⁴ with a competitive examination (common for medicine and odontology, with a limited pre-set number of places for the second year of PCEM).

The State or private grandes écoles or institutes have specific admission requirements. They recruit baccalauréat holders by a highly competitive entrance examination (concours) with limited pre-set numbers of places. Preparation for these examinations requires one or two years in preparatory courses for which selective admission requirements are also very high.

Some engineering schools accept students without preparation in special classes immediately after the baccalauréat. They require scientific types of baccalauréat and make a selection between baccalauréat holders either according to a competitive examination (concours) or according to performance in school (portfolio).

As engineering schools, business and management schools require a competitive entrance examination prepared in one or two years either in the CPGE or in courses offered by these schools themselves (integrated preparatory year).

5. CHARACTERISTICS OF DIPLOMAS¹⁵

The present time is a transitional period for the French higher education system. All existing and new diplomas have now to be integrated into the new European reference framework Licence/Master/Doctorate (LMD), grades normally obtained in 3, 5 and 8 years after the baccalauréat.

¹⁴ PCEM : *premier cycle des études médicales. About one candidate out of five is admitted.*

¹⁵ *The official terminology (decree 2002-481, 8 April 2002) makes a distinction between :*
grade : conferred by obtention of a national diploma at levels corresponding to the new european reference framework LMD : baccalauréat/licence/Master/Doctorate (end of secondary studies, plus 3, 5 and 8 years)

title : conferred by obtention of a national diploma at intermediate levels : DEUG, DEUST, DUP, DUT 2 years, maîtrise 4 years

diploma : degree obtained in a specific denomination at any of these levels

More information in English and French diplomas can be obtained on the website of the EduFrance Agency : www.edufrance.fr; as well as on many individual universities and higher education schools websites

Admission to higher education	+1 year	+2 years	+3	+4	+5	+6	+8 and more
Baccalaureate (BAEL)	<ul style="list-style-type: none"> health professions : competitive examination PCTM admission to IUP 	<ul style="list-style-type: none"> DEUG DEUP DEUST DUT BTS grandes écoles entrance competitive examination 	licence	<ul style="list-style-type: none"> maîtrise DEST MSE MAAGE 	<ul style="list-style-type: none"> DEA DESS graduate engineer diploma business and management schools diploma Master 	<ul style="list-style-type: none"> DEA and Thésaurat Synthesis Certificate (medical) 	<ul style="list-style-type: none"> Doctorate Habilitation

The universities confer two types of diplomas:

- national diplomas (diplômes nationaux), granted throughout the country, assuring an acknowledged standardized educational level, within the framework of national broad regulations (the “maquettes”) which lead to a “habilitation” of these diplomas by the Ministry of Education,
- university’s own specific degrees (diplômes d’université) are granted by individual universities to fulfill, in most cases, specific local and regional requirements. Practices and denominations regarding these ‘university-specific degrees’ and the diplomas of the non-university sector vary considerably. A specific category of university diplomas, aiming at excellence, the Magistère, was created in 1985 (level bac + 5). It can be awarded with three years of studies after the DEUG (or the DUT). There are 38 different Magistères.

For a long time, the universities were little oriented towards vocational training with the exceptions of the law and health professions, and of teachers’ training. Vocational higher education was mostly the responsibility of the “grandes écoles” and other institutes of higher education. This situation has changed very much in the last 40 years: universities, with adoption of a strong state voluntaristic policy have developed a number of vocational types of studies at various qualification levels. About 40 per cent of all registered students are at present studying in these types of studies.

The academic level at which a diploma is delivered is based on the length of time necessary for completing the required studies. This duration is generally expressed in time of the number of years of studies required after obtaining the secondary school-leaving certificate, the baccalaureate (baccalauréat) for completion of a given course programme. This is not an average but the normal minimum official duration. In the present situation, before a full implementation of the LMD framework (with a first cycle of 3 years, leading to the first terminal diploma, the “licence”, and a second cycle of 5 years, leading to the Master’s), existing diplomas are classified in three cycles (first cycle: bac + 2 years, second cycle: bac + 3 or 4 years, third cycle: bac + 5 years or more).

The universities offer short (two years) and longer studies. The first two years are either:

- a first cycle leading to a pluridisciplinary general education degree¹⁶, with mention of 11 broad branches or major fields of study: humanities, arts, languages, social sciences, law, economics and management, science and technology, leading to state diplomas which have equivalent value whichever the university. The DEUG prepares students for more specialized studies in the second cycle.

- short-study courses leading to a terminal vocational diploma (they are equivalent to a first university cycle: a DUT graduate may, in many cases, pursue higher studies leading to the licence and other degrees).
- (a) a technology diploma (DUT: bac + 2)¹⁷ in university technology Institutes¹⁸ (within the universities they have a certain range of autonomy) to train middle-level managers in industry and commerce (23 specializations such as business and administration management¹⁹, civil engineering, electrical engineering, social careers, etc.;
 - (b) a scientific and technical higher studies diploma²⁰, a professional diploma offered in various fields related to national or regional needs: more than 60 DEUST specializations in eight branches.

A number of technological secondary schools also prepare for an advanced technical diploma, the “higher technician degree” (BTS)²¹. This is a national diploma awarded in about 100 specializations in industrial and service sectors. It is prepared in post-baccalauréat “higher technician” classes in state or private technological secondary schools (2,068 classes in 2002-02 including 1,275 public and 793 private). BTS holders have approximately the same labour market opportunities as DUT holders, however with a less polyvalent and more specialised focus. Some upper secondary schools (lycées) offer an art crafts diploma (diplôme des métiers d’art - DMA - bac + 2) in 20 specializations, and an applied art crafts diploma (diplôme supérieur en arts appliqués – DSAA: DMA + 2).

The present second cycle (before implementation of the LMD scheme) is a continuation of the DEUG.

- The licence is the degree awarded after the first year of the second cycle (within the LMD scheme, it will become the degree obtained at the end of the new first cycle).
- The maîtrise is awarded after the second year. Licence and maîtrise can have a general orientation (formations fondamentales) or a professional orientation (formation à finalité professionnelle). Their specification (their “national denomination”) normally refers to a discipline: licence of Physics, Chemistry, English, History, etc., or a sub-discipline: maîtrise of Cellular Biology, biochemistry.
- Three specific maîtrise diplomas with a professional orientation were created in 1971:
 - (a) maîtrise de Sciences et Techniques - MST,
 - (b) maîtrise des Sciences de Gestion (MSG), and
 - (c) maîtrise des Méthodes informatiques appliquées à la gestion (MIAGE).
- DUT or BTS holders (bac + 2) can prepare during a third year a national diploma in specialised technology¹ (DNTS: bac + 3), or a university diploma.

Many of these diplomas have been updated and transformed into a new vocational licence degree²³, created in 1999. The vocational licence enables students to enter a profession after three years of university study, including as a first step completion of two years of university (DEUG) or two-

¹⁷ DUT : diplôme universitaire de technologie

¹⁸ IUT : Instituts universitaires de technologie

¹⁹ GEA : DUT - Gestion des entreprises et des administrations -

²⁰ DEUST : diplôme d'études universitaires scientifiques et techniques (bac + 2)

²¹ BTS : Brevet de Technicien supérieur (bac + 2)

²² DNTS : diplôme national de technologie spécialisé

²³ licence professionnelle

year short courses in technological subjects (BTS, DUT). This new degree is designed in cooperation with various sectors of industry (civil engineering, design and applied arts, etc.) or services (health, social work, environment, tourism, bank and insurance, etc.). It provides initial and ongoing training for intermediate posts at qualified technician and engineer level, and senior management level. Specific diplomas are delivered at each level by the university professional institutes (IUP)²⁴:

- (a) IUP general diploma (bac + 2)²⁵,
- (b) IUP licence (bac + 3), and
- (c) IUP maîtrise (bac + 4).

The third cycle offers two channels:

- a professional one, leading to one year of the post graduate professional degree (DESS)²⁶, and
- a research channel leading to one year of the post graduate research degree (DEA)²⁷. This degree usually prepares for an academic career. This diploma is a condition for the preparation of a doctorate, obtained three or four years after the DEA and after extensive research, either individual or as part of a group supervised by a Thesis Director.

Since 2000, the new Master's degree is automatically awarded to holders of a DEA or a DESS.

The doctorate may be followed by a post-doctoral degree, the "habilitation à diriger les recherches", which constitutes the highest national degree. It is conferred to academics who display abilities to carry out high level scientific research and to supervise research and doctorate thesis work. This is a condition for access to the full university professor title.

Grandes écoles and higher education institutes (écoles supérieures) award diplomas in engineering, business or commerce, generally three years after the DEUG, the DUT, or a preparatory cycle of two years in post secondary preparatory classes (CPGE in some upper secondary schools). Admission is usually by a preparatory cycle of two years after the baccalauréat, dedicated to basic scientific training and work methodology. The competitive entrance examination gives access to the three-year cycle.

The three-year engineering cycle in the engineering schools provides further general scientific training, training in the general techniques of the engineer, a scientific and practical training in the major field chosen by the student, a diversified training on foreign languages, communication, law, economics, management and social sciences, and internships of short and long duration every year (two to six months, for the last one including the preparation of an individual project ending the studies). The graduate engineering degree (titre d'ingénieur) is conferred by the engineering schools upon successful completion of five years of study after the baccalauréat. Since 2000, the new Master's degree is automatically awarded to holders of a graduate engineering diploma.

Holders of a maîtrise from an IUP and engineering students in their last year of engineering school can work towards a technological research diploma (DRT)²⁸, a third cycle diploma issued after completion of a course focussing on innovation through technological research in the

²⁴ IUP : Instituts universitaires professionnalisés

²⁵ diplôme d'études universitaires générales d'IUP

²⁶ DESS : diplôme d'études Supérieures Spécialisées

²⁷ DEA : diplôme d'études Approfondies

²⁸ DRT : diplôme de Recherche technologique

industrial sector and service industries. The DRT is obtained after successful completion of an 18 months to two years programme in an industrial or service-oriented scientific environment under the joint responsibility of two advisers, a teacher-researcher and an adviser from the industrial or service sector.

Equivalence and transfer possibilities between the universities and the grandes écoles have developed as well as conventions for granting joint degrees.

In Medicine, the second cycle (DCEM)²⁹ consists of four years of study and hospital internship. At the end of the DCEM, the Clinic and Therapeutic Synthesis Certificate Medicine (CSCT)³⁰ must be obtained for admission in the third cycle. The third cycle leads to the state diploma (diplôme d'Etat) of Doctor of Medicine and to certificates in specialized medicine (DES).³¹

4. ORGANIZATION OF STUDIES

Within the framework of national regulations, each institution defines and organizes the courses offered to students. A minimum of study hours is required for each type of national diploma:

DEUG	between 800 and 1100 hours during 2 years
Licence	between 350 and 500 hours, one year
maîtrise	between 350 and 500 hours, one year
IUP	between 1600 and 2000 hours during 3 years (DEUG/licence/maîtrise), plus languages, communication.

New principles, consistent with the new European framework, have been adopted for the new first cycle, leading to the Licence degree³², modifying and completing the former 1997 reform (decree 9/4/1997).

Universities are invited to propose bidisciplinary or pluridisciplinary innovations, with majors and minors, more diversified and flexible study paths for the students, managing bridges between courses in order to allow the students to take new orientations.

They have to adapt their courses to the variety of students and to get involved in pedagogical cooperation with other higher education, post-secondary and secondary education institutions in the same region.

Course units are defined as “logical groupings of courses and activities”. They include fundamental courses, discovery units and methodology units. The university year is divided into semesters. Evaluation of courses will be enhanced, involving the students in the process.

Introductory periods of information on the structure of studies, university life and professional perspectives of the studies chosen have to be organized. Each student must have an opportunity to benefit from tutoring in order to help him/her to determine and consolidate his/her orientation and choice of courses.

Universities determine their examination regulations, including continuing assessment, written and oral examinations or a combination of both. Procedures for assessing aptitudes and knowledge are laid down by the president of the university or the head of the establishment, and approved

²⁹ DCEM : deuxième cycle des études médicales

³⁰ CSCT : certificat de synthèse clinique et thérapeutique

³¹ DES : diplôme d'études spécialisées

³² études universitaires conduisant au grade de licence (23/4/2002)

by the Council for Studies and University Life (CEVU)³³. Courses can include practical training periods, the preparation of pluridisciplinary individual or collective projects. These are validated for awarding the diploma.

Capitalization is the rule, consistent with the ECTS system³⁴. A number of principles guarantee the students' rights as regards continuous assessment: compensation, absence of elimination mark, anonymous examination papers, communication of notes and papers results, individual interviews to comment on the results, and the organization of two examination sessions, at an interval of at least two months. Practical implementation of these must be made known to students and cannot be changed during the academic year.

The DEUG studies (four semesters) begin with a semester of orientation, allowing the student to explore the university and the subject chosen, but also allowing him to make a change early enough not to lose a full year.

In the second semester a choice has to take place between:

- continuation in the DEUG or DEUG part initially chosen,
- continuation in another DEUG or DEUG part corresponding to the discovery unit,
- request to change for a new type of course such as STS, IUT, etc.

Re-orientation in the first semester is linked to the exploratory unit. Changes are made more particularly under agreements concluded with fellow institutions.

5. DISTANCE LEARNING

The national centre for distance learning (CNED)³⁵ is placed under the responsibility of the Ministry of Education. It offers distance learning and courses in all levels and fields (university diplomas, business courses, accounting, etc.) in cooperation with the universities. The CNED has also implemented an "Electronic Campus" programme which enables users to access all the functions they would find on a real campus - a person to talk to, analysis, courses, a library and a resource centre. It also offers specific courses leading to the competitive examinations for teachers of all categories, and for the administrative staff of the Ministry of Education. By agreement with other government departments, it also offers courses leading to competitive examinations for staff in other departments of the civil service. The CNED also has an active international policy with partnerships and bilateral agreements.

6. CONTINUING EDUCATION

Continuing education is provided by all higher education institutions. They offer three types of training:

- short training periods for businesses and government departments,
- long training periods which may lead to granting of university diplomas, and
- training leading to national diplomas, particularly the vocational types of diploma.

The courses may take different forms:

- specific organization for continuing education students (full- or part-time training periods);

- continuing education courses designed for people already in full-time employment (evening classes, day or half-day courses, distance learning, etc.);
- sandwich courses (“alternate” courses), mixing theoretical training and practice periods in business or industry; and
- integration of continuing education students into initial education courses.

7. DEGREE CONFERRING AGENCIES

The state has a monopoly on the awarding of national diplomas³⁶. The existing private universities (essentially the five catholic universities) cannot award national degrees to their students who must sit in the same examinations required of students in the public universities.

Upon application by the universities, the Minister of National Education confers the authority (“validation”) to grant the “national diplomas” (diplômes nationaux). This authorization must be renewed, in the case of each diploma, after four years. General rules concerning the duration, curricula and examinations of the respective courses are laid down by the Ministry as a condition for “validation” in order to ensure an equal value of the respective diplomas. The national diplomas “validated” by the Ministry of Education, are awarded by universities on behalf of the state.

The “university diplomas” (without the recognition as national diplomas) are awarded by the universities themselves.

The graduate engineer title (diplôme d’ingénieur) is protected by law. The quality of engineering studies is guaranteed on a national level by a “Commission on Engineering Titles”(CTI)³⁷. In the public sector, the authority to grant that title is conferred by the Ministry of National Education or by other ministries in charge of supervision of engineering schools. The list of accredited schools (for a maximum six years period, renewable after an evaluation by the CTI) is published in the State Official Journal. Some universities have also been entitled to award this diploma.

8. ASSESSMENT TO INSTITUTIONS, COURSES, AND DIPLOMAS

Assessment of institutions is made periodically (every seven years) by the National Evaluation Committee for Higher Education Institutions (CNE)³⁸. It was created by the 1984 Higher Education Law which has organized universities’ administrative, pedagogical, research and financial autonomy. The CNE publishes reports on each evaluated institution as well as a general annual report. It is also engaged in cross-institution evaluations by disciplines for the whole country: it has published general assessments of the state of higher education in geography, odontology, engineer training in chemistry, information and communication sciences. It also conducts evaluations on general higher education topics such as the status of academic and non-academic staff, the professional paths of degree-holders, etc.

The CNE is not under the authority of the Minister in charge of higher education. The July 10, 1989 Law makes it an autonomous administrative entity which reports directly to the President of the Republic. The CNE is financed by the state and has got its own budget.

³⁶ Law No. 84-52, 26/1/1984, on higher education, art. 17

³⁷ CTI : Commission des titres d’ingénieur

³⁸ CNE : comité national d’évaluation des établissements publics à caractère scientifique, culturel et professionnel

A general principle of evaluation is seen as a condition to guarantee the validity of the national diplomas framework. Assessment of courses and diplomas is made periodically by experts committees in the Ministry of Education through the “validation” procedure which grants and renews the recognition by the state as “national diplomas”. This is to take place every four years by elaboration or update of the university’s project (its strategy statement)³⁹ and the correlated negotiation of a four-year contract with the Ministry of Education (directorate for higher education). This contractual policy between the Ministry of Education and the universities aims at bringing together priorities of every higher education establishment in accordance to national policies for the development of higher education and research.

Universities projects are analyzed by an evaluation committee in the Ministry of Education⁴⁰. The elaboration of new courses within the new European framework Licence/Master/Doctorate is followed up by a monitoring committee of the Licence degrees, and a monitoring committee of the Master’s degrees.

In the engineering schools sector, all programmes are reviewed (normally every six years) by the Commission on Engineering Title (CTI). The “Commission des titres d’ingénieurs” is a national engineering degrees accrediting body. It is made up of 32 experts (one-half representing different groups of the professional world, the other half representing the schools). It has its seat at the Ministry of National Education. It plays an essential role in the decision to authorize a degree by regularly assessing programmes of the engineering schools entitled to grant the diplomas. The Commission takes charge in monitoring the quality of education in the engineering schools. It advises each concerned Minister before decisions to grant the authority to grant the diploma. It decides autonomously with regard to the private engineering schools.

In the business and management schools sector a commission of evaluation of courses and degrees has been set up to implement the obligation of periodical evaluation (every six years).⁴¹

The reputation of the universities and schools in the non-university sector depends also largely on a variety of other factors such as:

- the difficulty of admission and the results (stricter selection procedures, when legally authorized, attract qualified students, and this selection increases the percentage of good results in getting the diplomas),
- the recognition of degrees in collective agreements (conventions collectives) for each activity sector,
- the positions and salaries of their graduates in professional life: most universities are monitoring these data through various surveys, feeding back this information to students,
- the students views on quality and efficiency of the teaching received: since 1997 an assessment procedure must be set up for each course. It must take students’ views into account,

³⁹ *projet d’établissement*

⁴⁰ *CEPPE : Comité d’expertise pédagogique des projets d’établissements*

⁴¹ *CEFDG : commission d’évaluation des formations et diplômes de gestion. A form of accreditation is provided by the inscription on an official list of establishments authorized to deliver degrees accredited (“visés”) by the ministry in charge of higher education.*

- the level of research (reputation of the scholars employed, third cycle diplomas granted, links with research institutes), and
- periodic comparisons between the various universities and their different subject courses published by the media.

9. INTERNATIONAL RECOGNITION OF DIPLOMAS

There is no systematic legal equivalence between foreign and French qualifications and diplomas.

Recognition of diplomas is usually dealt with within the framework of co-operation in the Council of Europe, UNESCO and the European Union which has led to several multilateral agreements concerning admission, equivalences, academic recognition of university qualifications.

An agreement on recognition of qualifications (degrees and diplomas) for higher education in Europe has been adopted in Lisbon in April 1997. The Lisbon convention assumes a trust principle between participating countries about the effectiveness of quality assurance and accreditation in each country. This includes a “diploma supplement” issued to students obtaining a degree. Developed by the European Commission, the Council of Europe and UNESCO/CEPES, this “diploma supplement” describes the type, level, context and the status of diplomas or degrees in a standardized way.

Requests for recognition of foreign diplomas are examined on a case-by-case basis by each autonomous higher education institution which makes decisions about admission. Decisions are made by the university presidents, and based not only on diploma titles, but also on course contents, duration, and the establishments where the course was taken and the diploma awarded. Assistance in this process can be given to the institutions, employers and the individual candidates by the NARIC (National Academic Recognition Information Centres) scheme created in 1984 within the framework of the European Union (Erasmus and Socrates programmes) in order to facilitate students’ mobility. The French NARIC is located in the Ministry of Education (directorate for international relations and cooperation)⁴².

⁴² Website of the Ministry of Education : www.education.gouv.fr

1. COUNTRY PROFILE

The higher education system of the Federal Republic of Germany comprises the following types of higher education institutions:

1.1 Universities

The universities, technical universities (*Technische Universitaeten/Technische Hochschulen*) and institutions offering only specific university-level subjects are responsible for conducting research, teaching and studies as well as promoting highly qualified young scientists and artists. Therefore, they are entitled to award doctorates (*Promotionsrecht*) and to certify additional academic achievements in research and teaching of a specific discipline (*Habilitationsrecht*). They offer a range of subjects from theology and the humanities to law, economic and social sciences, natural and engineering sciences, agricultural science and medicine. However, universities also include institutions specializing in medicine, veterinary medicine, administration science and sports science as well as two *Bundeswehr* universities for officers in the federal armed forces.

The former *Universitaeten-Gesamthochschulen* (comprehensive universities), in Hesse and North-Rhine/Westphalia are from 2003 on universities without the supplement “*Gesamthochschulen*“.

1.2 Fachhochschulen (Universities of Applied Sciences)

Fachhochschulen serve a specific purpose of their own in the context of the function common to all higher education institutions of providing an academic education. Most of their courses of study are offered in the engineering sciences, economics and economic law, social work/social services, public administration/administration of justice, information technology/computer science, design, mathematics, information and communication studies, nursing and management in the public health system. The courses of study themselves and the organization of teaching and study are very much oriented to the demands of professional practice. The research and development work performed at the *Fachhochschulen* is likewise aimed at specific applications and is complemented by scientific consultancy work and organized technology transfer activities.

1.3 Paedagogische Hochschulen (Colleges of Education)

Paedagogische Hochschulen train teachers for *Grundschulen* and certain types of lower secondary school as well as *Sonderschulen* (special schools). There is also a course leading to a *Diplom* in education sciences (*Diplom-Paedagoge*). All other types of teachers are trained at universities, technical universities (*Technischen Universitaeten/ Technischen*

Hochschulen) as well as *Kunsthochschulen* and *Musikhochschulen* (colleges of art and music). In the 1970s, most of the *Paedagogische Hochschulen* became part of universities. Nowadays they exist in their own right only in Baden-Wuerttemberg.

1.4. *Kunsthochschulen (Colleges of Art) and Musikhochschulen (Colleges of Music)*

Kunsthochschulen and *Musikhochschulen* offer courses of study in the visual arts, design and performing arts and in music disciplines, some of them even in the related scientific disciplines (arts-related sciences, history of art, musicology, history of music, music education). It is one of the main distinguishing features of a *Kunsthochschule* or *Musikhochschule* that the artistic training takes the form of individual instruction or instruction in small groups (classes).

Art and music courses of studies lead to a *Diplom* (first degree), to the nomination of a *Meisterschueler* (member of a master's class), the *kuenstlerische Reifepruefung* (final arts examination) or the *Konzertexamen* (concert examination).

Apart from the above-mentioned courses for artistic training the colleges of art and music also offer teacher training courses of study entitling graduates to start a career as an art or music teacher at school after having passed the relevant *Staatspruefung* (state examination) and completed the *Vorbereitungsdienst* (preparatory service).

1.5 *Berufsakademien (Professional Academies)*

Berufsakademien (Professional Academies) combine a three-year academic training at a *Studienakademie* with practical professional training in the workplace. Courses offered include, in particular, business, technology and social services. Students who successfully complete their *Diplom* examination are awarded a qualification for entry into a profession (e.g., *Diplom* degree in Engineering – *Diplom-Ingenieur* to which the abbreviation B.A. for *Berufsakademie* is added).

1.6 *Distance learning*

Apart from higher education institutions which require the presence of the student, there are others offering correspondence courses. The *Fernuniversitaet* Hagen, for instance, runs university-level courses leading both to *Diplom*, *Magister* and Bachelor's degrees in six subject areas as well as further study, supplementary and follow-up courses (*postgraduale Studiengaenge*).

2. CHARACTERISTICS OF DIPLOMAS

2.1 *Denominations, examinations, disciplines*

In the Federal Republic of Germany, the following categories of final examinations exist and, on successful performance in the examinations, candidates are conferred the appropriate title.

The *Diplom* (in German usage *Diplom* denotes an academic degree) is an academic degree especially in science, engineering, social science and economic subjects, mainly conferred by the universities and the *Fachhochschulen*. It constitutes a full academic and professional qualification which entitles the holder to work independently in the corresponding professional field. During the diploma course programme, students must pass an interim examination thereby receiving a certificate, *Vor-Diplom*. This does not certify successful completion of studies; any person who

applies for employment having only passed this pre-diploma would be considered to have dropped out of the full diploma course programme. The final *Diplom* examination entails the completion of a thesis in general within a period of 6-9 months (universities) or within 3-6 months (*Fachhochschulen*) in addition to a comprehensive set of written and oral examinations. The examinations are administered by the professors of the respective institutions.

There is made a distinction between the *Diplom* of a University and a *Fachhochschule*. In a *Fachhochschul-Diplom* the abbreviation (FH) is added - FH means *Fachhochschule*. Holders of a University-*Diplom* are eligible for direct admission to a doctorate, holders of a *Fachhochschul-Diplom* have to fulfill additional requirements. Admittance to doctoral studies is regulated in the *Promotion* regulations of the universities. There are several procedures in place for admitting particularly qualified holders of a *Diplom* obtained at a *Fachhochschule*.

The *Magister* is an academic degree mainly in the humanities and social sciences which is conferred only by the universities or by institutions of equivalent standing. The degree of *Magister*, contrary to that of the *Diplom*, is not closely related to any particular professional field. Corresponding course programmes must be completed either in two major subjects or in one major and two minor subjects. The *Magister* represents an equivalent level of education as the *Diplom* and the *Staatsexamen* (below). Examinations are set and administered by the professors of the university. Holders of a *Magister* degree are eligible for direct admission to a doctorate.

The *Staatsexamen* (First State Examination) is held in the following disciplines: medicine, pharmacy, dentistry, veterinary medicine, food chemistry, law and teacher training. The *Staatsexamen* is equivalent to the *Diplom* and the *Magister*, the difference between them lying in the purpose and formal organization of the examination rather than in the structure and contents of the course programme. The *Staatsexamen* is administered by university professors and by officials of public examination bodies in compliance with state laws and regulations. While the course programmes and examinations are set by state laws and regulations, the responsibility for the academic quality and scientific contents is left to the university.

The award of the *Staatsexamen* entitles its recipient to be admitted to doctoral programmes. It is also considered as qualification for entry into civil service positions or into the professions of medicine, pharmacy, law and teaching. However, the First *Staatsexamen* is not a professional qualification per se and must be validated on completion of formal training and after passing a second examination with additional certification (Second State Examination).

Introduction of Bachelor and Master Degrees at German Universities

In order to improve the compatibility between German and foreign qualifications, especially with a view to adequate classifications of foreign students with a Bachelor's degree in the German higher education system and for mutual recognition in similar educational and professional systems, the Hochschulrahmengesetz (Framework Act for Higher Education) provides since 1998 the possibility for German higher education institutions to introduce Bachelor's and Master's programmes instead or in addition to the existing *Diplom*, *Magister* and *Staatsexamen* courses. According to the Anglo-American system of education a Bachelor's degree awarded by a German university after three to five years duration should grant immediate professional access. The Master's degree as a post-graduate qualification should comprise one or two years duration. Both the Bachelor's and the Master's degrees are offered by universities, *Fachhochschulen* and colleges of art and music as well.

Postgraduate Studies and Degrees

Under specific subject-related conditions students may take post-graduate courses, supplementary study programmes or complementary study programmes at most higher education institutions after acquisition of an academic degree (*Diplom, Magister, Master*) or after passing the First State Examination. These courses allow students to gain a further professional qualification, to specialise in one area or to pursue further studies. There are no uniform regulations for degree programmes of this kind. They may last from anything between a few weeks or months up to several semesters. These courses are concluded with the award of a certificate or, under certain conditions, an academic degree. The following qualifications may be conferred by the institutions of higher education on completion of various advanced course programmes (special graduate studies) which are documented by the Association of Universities and other Higher Education Institutions in Germany (www.higher-education-compass.de).

- Abschlussprüfung
- Diplom
- Diplom (FH)
- Konzertexamen
- Licentiatenprüfung
- Magister
- Master
- Staatsexamen (supplementary state examination)

Research qualification

The advanced qualifications which may be conferred are the doctoral degree (*Promotion*) and the *Habilitation*. Both are awarded for scholarly research and examinations and are in general not dependent upon the completion of periods of study or course programmes.

Requirements for the doctorate are determined by the individual faculties; only regulations for entry, the thesis and examinations are formally set down. There are no special “doctoral programmes” as in other countries, doctoral work starts with the elaboration of a dissertation. Completion of the thesis usually entails a three- to five-year period of study subsequent to the first degree and is followed by an oral examination in the major, and often two minor, subjects.

The doctoral degree traditionally refers to the major groups of disciplines (abbreviated to Dr.Phil.; Dr.Rer.Pol.; Dr.Med., etc.). In recent years, however, some universities, have introduced more specific doctoral titles. About 45 different doctoral titles are employed by German university-level institutions, for example Dr.Rer.Oec. (doctor rerum oeconomicarum). With the exceptions of two cases (Dr.Ing., Dr.Sportwiss), the title is given in the Latin language (www.higher-education-compass.de → Doctorates).

German doctoral degrees are comparable to a “Doctor of Philosophy” (Ph.D.) in the Anglo-American system of higher education. With the amendment of the Higher Education Framework Act (HRG) in 2002 the *Habilitation* (a post-doctoral lecturing qualification) is no longer a prerequisite for a professorship. The additional academic qualifications formally demonstrated by the *Habilitation* have to be acquired during the activity as a junior professor. Junior professors may compete for professors’ posts and take part in the *Berufungsverfahren* (appointment procedure).

2.2 Disciplines or fields of study

Universities usually offer a range of subjects including humanities, law, economics and social sciences, natural sciences, medicine, agronomy, forestry and nutritional science and engineering sciences. The figures vary from institution to institution, but these or similarly designated faculties offer more than 2,700 different degree courses, which cannot all be listed here. The most common branches of study are:

Languages and Humanities, Sports

- Philosophy
- Theology
- Archaeology and Study of Antiquity
- History
- Art Studies/Art History
- Musicology/Music History
- Theatre Studies/Dramatic Art
- European and Non-European Languages and literature
- Education
- Psychology
- Library Science/Documentation Science/Media Studies
- Sports

Law, Economics and Social Sciences

- Law
- Social Sciences
- Public Administration
- Economics
- Political Science

Mathematics, Natural Sciences

- Mathematics
- Physics
- Computer Science
- Chemistry
- Biochemistry
- Biology
- Earth Science
- Pharmacy

Medicine

- Human Medicine
- Dentistry
- Veterinary Medicine

Agronomy, Forestry, Nutritional Science

- Agronomy
- Forestry
- Nutritional Science

Engineering Sciences

- Architecture
- Civil Engineering
- Geodesy
- Electrical Engineering
- Mechanical Engineering
- Chemical Engineering
- Traffic and Transport Studies
- Environmental Technology
- Mining

Concerning the range of subjects at *Fachhochschulen* study courses in the following areas of study are taught above all:

- Engineering Sciences
- Economics/Economic Law
- Social Work, Social Services
- Public Administration, Administration of Justice
- Computer Science, Information Technology
- Design
- Mathematics
- Information and Communication Studies
- Nursing and Management in the Public Health System

Courses of study in Colleges of Arts and Music vary widely from college to college. In general, they may be divided along the following lines:

- music comprising such studies as training for solo or orchestra musicians in various instruments, training in singing, conducting, composition or church music, music teaching at general education schools and technical musical professions (e.g. sound engineering);
- visual arts comprising such studies as art, design, photography;
- performing arts comprising such studies as drama, opera, musicals, dancing, directing and film-making;
- applied art with courses of study in architecture, design or the media;
- art education and art therapy as well as courses in art teaching for school teachers; and
- the media with such courses as media studies, media art, animation and media management.

2.3 Issue of documents

The diploma documents awarded on successful completion of studies and in the final examination always name the institution of higher education at which the student was registered when he sat for the final examination. If the student moved from one institution to another (according to the German university tradition, a student can move freely from one institution to another at any time during his studies), the institutions at which the student was previously registered will not be named.

The *Staatsexamen* certificate in the disciplines medicine, dentistry, veterinary science, pharmacy, food chemistry, teaching and law are, as they are regulated by state regulations, not issued by universities but by the competent state or professional bodies, e.g., examination committees. The title of the certificate though not being an academic degree but on the same level as a Diploma or Magister refers to the profession.

3. GRADING SYSTEM

In the scheme of the individual subjects for the examination of academic degrees as well as for state examinations, the following grades are used:

- 1 = *sehr gut* (very good)
- 2 = *gut* (good)
- 3 = *befriedigend* (satisfactory)
- 4 = *ausreichend* (sufficient)
- 5 = *mangelhaft* (insufficient)

In the cases of the *Diplom* and *Magister*, the aggregate grade is calculated on the same grading scheme. If the average grade is 1.5 or higher, the grade will be *sehr gut*. If the average grade is lower than 4.0, the student will be considered to have failed and will not be awarded a degree.

An overall grade is calculated on the basis of grades in individual subjects:

	1.0 to 1.5	-	very good
above	1.5 to 2.5	-	good
above	2.5 to 3.5	-	satisfactory
above	3.5 to 4.0	-	sufficient.
above	4.0	-	insufficient

In most cases, the numerical average grade will be found in brackets following the verbal grade, for example *gut* (1.7).

In the case of state examinations, the verbal grades employed might differ slightly especially in the case of law. For example, the numerical grades for individual subjects in the final examinations for teacher training follow the scale mentioned above; however, the aggregate/overall verbal grades are as follows:

<i>mit Auszeichnung bestanden</i>	(pass with distinction)
<i>gut bestanden</i>	(pass with merit)
<i>befriedigend bestanden</i>	(satisfactory pass)
<i>bestanden</i>	(pass)
<i>nicht bestanden</i>	(failing)

The grades awarded in the doctoral examinations differ from institution to institution. In some rare cases they are in the German language; in general they are in the Latin language. As a rule, the grading scheme differs from that used for the *Diplom*, *Magister*, and *Staatsexamen* in two respects:

- There is an additional grade for the highest achievement: 0, which is either awarded in all subject areas or is employed when the average grade is 1.0. It is verbally expressed as *ausgezeichnet*, *summa cum laude* or similarly.
- There is only one grade for achievement lower than the level of good. It may be verbally expressed as *genuegend*, *rite* in Latin, or similarly.

Thus the grading scheme might, for example be:

0 =	<i>Ausgezeichnet</i> or <i>summa cum laude</i> ,
1 =	<i>Sehr gut</i> or <i>magna cum laude</i> ,
2 =	<i>Gut</i> or <i>cum laude</i> ,
3 =	<i>Genuegend</i> or <i>rite</i> .

Only very few departments do not grade the examinations, but instead, provide written reports on the graduate's achievements.

4. INTERNATIONAL RECOGNITION OF DIPLOMAS

As a member of the Council of Europe, Germany benefits from the conventions on academic recognition dealing with admission to universities, recognition of periods of study and recognition of university qualifications and degrees for admission to doctoral programmes.

As a member of the EU (and of the EEA) Germany participates in the implementation of the Directives for Professional Recognition in the "Regulated Professions" (medical doctor, lawyer, dentist, veterinary surgeon, architect and pharmacist) and in the General Directives for recognition for the access to and exercise of regulated professions for which sectorial Directives do not exist. Those Directives can only be applied on qualifications obtained by EU-/EEA-nationals in EU-/EEA-countries. Where Directives of the EU cannot be applied, recognition takes place in correspondence with German laws which demand full equivalency for professional recognition.

Bilateral agreements between German universities and universities in other states as well as state agreements between Germany and other states (Austria, France, The Netherlands, Hungary, Switzerland, Italy, Spain and Poland) enhance mobility and recognition. To promote internationalization Germany has decided to introduce a Bachelor- and Master-System apart from its own system. Some university programmes are offered in English, in many universities doctoral dissertations may be presented in English. Degree documents will in the future be issued in the English language.

German degrees should be recognized in the Anglo-American higher education system as follows:

Diplom of a university	=	Master's degree
Master degree	=	Master's degree
Diplom of a <i>Fachhochschule</i>	=	Bachelor's Honours degree
Bachelor degree	=	Bachelor's Honours degree
Doctorate	=	Doctor of Philosophy

On the recognition of university degrees for academic purposes such as admission to a doctorate and further studies or the recognition of periods of study the universities decide out of their own right. For professional access the competent professional body is responsible; the use of the academic degree in the Federal Republic of Germany has to be granted by the regional Ministry of Science. The above named institutions may ask the *Zentralstelle fuer auslaendisches Bildungswesen* (Central Office for Foreign Education) for a recommendation before taking their final decision. Useful information on transfer matters and procedures may be obtained at the German Academic Exchange Service. The address is:

Deutscher Akademischer Austauschdienst
Kennedyallee 50
53175 Bonn
Federal Republic of Germany
www.daad.de

5. ACCESS TO HIGHER EDUCATION

5.1 For Germans

A school leaving certificate qualifying pupils for higher education (*Hochschulreife* or *Fachhochschulreife*), is required for admission to any course of study at this level. There are three different types of qualifications for admission to higher education:

- the certificate attesting the *allgemeine Hochschulreife* (general higher education entrance qualification) entitles its holder to study at any higher education institution without restriction as to the subjects or subject areas,
- the certificate attesting the *fachgebundene Hochschulreife* (subject-restricted higher education entrance qualification) is the passport to specific study programmes at universities or equivalent institutions of higher education as well as *Fachhochschulen*, and
- the certificate attesting the *Fachhochschulreife* (*Fachhochschule* entrance qualification) allows its holder to enrol at a *Fachhochschule*.

A certificate attesting the *allgemeine Hochschulreife* or *fachgebundene Hochschulreife* (general or subject-restricted *Hochschulreife*) is generally obtained on the completion of the 13th grade at school at the end of the *gymnasiale Oberstufe* or at the end of vocationally oriented upper-secondary courses also leading to the general *Hochschulreife*. In some *Laender*, the general higher education entrance qualification can also be awarded after 12 years of school,

either generally or within the scope of pilot projects in schools. To guarantee the mutual recognition of the *Abitur* obtained after this shorter course, those *Laender* have to ensure teaching of a total of at least 265 weekly periods in the lower secondary level and the *Gymnasiale Oberstufe*.

The *Fachhochschulreife* certificate is normally awarded at a *Fachoberschule* after 12 consecutive years of schooling. It is also possible to obtain the *Fachhochschulreife* through special courses offering additional lessons, for instance at *Berufsfachschulen* and *Fachschulen* originally intended to lead to vocational qualifications.

A number of *Laender* have provisions granting other means of access to higher education for persons who have the right aptitudes by virtue of their professional experience but lack formal entrance qualifications. They have to show that they possess the required knowledge and the ability to study at a university by means of an entrance procedure (e.g., through provisional matriculation for a trial period) or an examination (assessment, aptitude examination, interview) at the higher education institution in question. Such candidates are normally admitted to a specific course of study following the vocational qualification they obtained previously.

Prospective students at *Kunsthochschulen* and *Musikhochschulen* (art and music colleges) are not only expected to have the required formal qualifications (*Hochschulreife*) but also have to demonstrate their artistic aptitude. In most *Laender*, entrance to exclusively artistic courses of study (but not to teacher training courses), is also open to applicants without the *Hochschulreife* if special artistic talent is demonstrated. Another exception is the practical aptitude test for applicants to study sports. Not all institutions insist on this test, especially not if the courses of study lead to a qualification as sports teacher or sports scientist.

There are currently restrictions throughout Germany on admission to courses of higher education in certain subjects (e.g. medicine, veterinary medicine, dentistry, architecture and business studies) because of the large number of applicants and insufficient capacity. Places on such courses are awarded by the Central Office for the Allocation of Study Places (*Zentralstelle für die Vergabe von Studienplätzen*) on the basis of a general selection procedure.

The range of subjects included in the nationwide selection procedure may vary from one semester to the next. Places on courses of studies with limited student numbers are allocated above all on the basis of average marks in the higher education entrance qualification certificate, waiting time (time between *Abitur* and application), and social criteria. For some courses there is a nationwide allocation procedure in which every applicant receives a place, but not necessarily of the institution of his/her choice.

A number of higher education institutions have local selection procedures on admittance to courses not included in the nationwide selection procedure. In that case the institution will choose among the applicants itself using such criteria as average marks and waiting time.

5.2 For foreign applicants

Foreign applicants for admission to an institution of higher education in the Federal Republic of Germany must, as a basic requirement, present a secondary school-leaving certificate which entitles them to university entrance in the country of origin. If the certificate is considered equivalent to the German higher education entrance qualification, the holders are directly admitted to course programmes at German institutions of higher education.

In those cases, however, where equivalence cannot be established, the foreign applicant must take a special examination called “Feststellungsprüfung”, which is an examination to determine the eligibility of foreign applicants to study at universities in the Federal Republic of Germany. The *Feststellungsprüfung* is usually taken after completing a pre-university preparatory course which lasts two semesters and is held at institutions called *Studienkollegs*.

Foreign students have to send their applications directly to the Universities or *Fachhochschulen*. Students from EU-member states who wish to study a German nationwide “numerus clausus-subject” (a subject for which a certain accumulated passing grade of the higher education entrance qualification is required) have to apply at the *Zentralstelle für die Vergabe von Studienplätzen*, 44128 Dortmund. In addition, foreign applicants must prove that they have a sufficient command of the German language. This can be done by taking the:

- *Deutsche Sprachprüfung für den Hochschulzugang ausländischer Studienbewerber* - DSH (German Language Proficiency Examination for Admission to Higher Education for Foreign Applicants)
- *Test Deutsch als Fremdsprache für ausländische Studienbewerber* (Test DaF) with results in all 4 examinations on level III
- *Deutsches Sprachdiplom der Kultusministerkonferenz - zweite Stufe* - (Beschluss der KMK vom 16.3.1972) (German Language Diploma of the Standing Conference of The Ministers of Education and Cultural Affairs)
- *Das Grosse oder Kleine Deutsche Sprachdiplom des Goethe-Instituts* (German Language Diploma of the Goethe-Institut)
- *Zentrale Oberstufenprüfung (ZOP) des Goethe-Instituts* (Central Higher Grade German Language Examination of the Goethe-Institut).
- The certificate on passing the *Feststellungsprüfung* comprises also the proof of sufficient command of the German language.

6. SEQUENCE AND DURATION OF STUDIES

6.1 Courses of study

In the customary university graduation system the first degree courses of study are divided into two sections: the *Grundstudium* (basic studies) and the *Hauptstudium* (advanced studies) both of which are terminated with an examination. The intermediate examination of the *Grundstudium* is normally taken after the 4th semester and tests whether students have learned the fundamental principles and scientific methods relating to their subject. Students are examined on the entire range of material taught during the first four semesters of the degree programme.

After having passed the intermediate examination, students receive a certificate called the *Vordiplom* or *Zeugnis ueber die Zwischenprüfung*. They are then allowed to attend courses of the *Hauptstudium*. It has to be stressed that the certificates given after the *Grundstudium* do not represent final diplomas. Students have to finish the *Hauptstudium* and the final degree examination in order to be awarded the degree *Magister* or *Diplom* or *Staatsexamen*.

In the recently introduced new graduation system with consecutive study courses the Bachelor's study courses generally concentrate on a scientific core subject. Master's study courses require a first degree qualifying for entry into a profession and lead to the Master's degree. The examinations are in general performed as an accompaniment to studies (introduction of modules). In addition, the study courses are linked with a credit-point system.

6.2 Duration

The examination regulations include a standard period of study (*Regelstudienzeit*) for the length of each course. This indicates the time in which a course of study can be completed with the relevant examination. It usually varies between eight and ten semesters for most university courses leading to the *Diplom*, *Magister* or *Staatsexamen*. At *Fachhochschulen*, the standard period of study is eight semesters. Students studying medicine have to study six years and three months. On an average, however, students take one or two years longer to finish, i.e., many students only attain the leaving certificate after studying for five years or more.

The total standard period of study for consecutive Bachelor's and Master's study courses is a maximum of five years. The standard period of study for Bachelor's study courses can be a minimum of three to a maximum of four years and for the Master's study courses a minimum of one to a maximum of two years.

6.3 Academic year

The academic year is divided into semesters. The summer semester runs from April to September, the winter semester from October to March. Lectures in the winter semester are usually held from late September/early October until mid/late February, in the summer semester they are held from mid April to mid July. A period of three months without lectures at the *Fachhochschulen* and five months at other higher education institutions gives students time to prepare for seminars, to undergo practical training and to sit for examinations.

6.4 Seminars and lectures

Students may receive instruction in the form of lectures, introductory and advanced seminars (*Proseminare*, *Hauptseminare*), exercises, practicals or excursions.

Lectures are designed first and foremost to provide the students with the general and background knowledge they need for their courses. Seminars give them the opportunity to take a closer look at a strictly defined topic on which they may want to do research in their final examination paper. Sometimes students are required to sit aptitude tests before they are allowed to proceed with certain seminars, exercises and practicals. They are expected to do both oral and written work for which they receive course certificates (so-called *Scheine*). These course certificates (*Scheine*) are needed to be admitted to the final examinations and they constitute the main form of performance assessment during the course of study. In the experimental sciences, the practical exercises students carry out in connection with lectures, notably compulsory laboratory work, provide a basis for continuous assessment of performance.

If work experience is part of the course programme, a pre-requisite for enrollment or the completion of studies, it is in most of the cases additional to the duration of study given above.

7. WORK EXPERIENCE AS PART OF THE CURRICULUM

In many course programmes at German institutions of higher education students are required to spend some time in work experience. In some fields, for example in teacher training practical training periods in school are part of the study courses at a higher education institution or in medicine, such practical periods are mandatory throughout all institutions. At *Fachhochschulen* the integration into the course of one or two semesters of work experience (*Praxissemester*) is also mandatory. The *Fachhochschule* lays down the rules for and content of these training periods, supervises them and provides parallel classes. They are spent in a company or in another place of work for a duration of at least 20 weeks.

8. DIPLOMAS AND PROFESSIONAL COMPETENCE

The degrees awarded in Germany within the customary graduation system (*Magistergrad, Diplomgrad, Staatsexame*), have a dual profile. On the one hand, they give access to doctoral studies and on the other hand, they give entrance to certain professions. The *Staatsexamen* has to be taken in those fields of study which prepare students for professions of particular importance to the public interest. This is the case in medicine, dentistry, veterinary medicine, pharmaceuticals, food chemistry, law and the teaching profession. After the first state examination, prospective lawyers and teachers, in particular, undergo a second phase of training called preparatory service (*Vorbereitungsdienst*), which is concluded by another state examination. Only this second state examination entitles them to practise their profession.

Since the amendment to the Framework Act for Higher Education of 1998 higher education institutions are also entitled to award Bachelor's or Master's degrees independently of any cooperation with a foreign institution of higher education. The degrees awarded in the consecutive study courses are qualifying for entry into a profession. Bachelor study courses generally concentrate on a scientific core subject. Master study courses require a first degree qualifying for entry into a profession and lead to the Master's degree. For study courses with a more theoretical orientation, the Bachelor/Master of Arts or Bachelor/Master of Science is awarded. In the case of study courses that are more application oriented, the actual degree has a subject-related supplement (e.g. Bachelor/Master of Engineering).

9. ACCREDITATION, ASSESSMENT, RANKING

Higher education institutions in Germany are ruled by a framework of laws issued by the Federation and the *Laender*, defining the status of the institutions, regulating their organization and the degrees they may confer and stating the requirements for the recruitment of the staff. Through this system of state monitoring by the ministries and the public funding a homogeneous standard of higher education education is guaranteed in Germany. Therefore, assessment procedures as applied in other countries are considered not necessary. The Standing Conference of the Ministers of Education and Cultural Affairs co-ordinates through the general framework the study regulations and examination regulations of the respective higher education institutions.

For the new Bachelor's and Master's study courses, the Standing Conference of the Ministers of Education and Cultural Affairs has declared a functional separation between state approval and accreditation with regard to quality assurance, as with the other study courses, the state approval

refers to guaranteeing the fundamental financial means for the study courses to be set up, the inclusion in the higher educational planning of the respective Land, as well as the maintenance of structural requirements. In contrast to this, the objective of the accreditation is to guarantee minimum standards in terms of academic content and to check the vocational relevance of the degrees. It is to increase the diversity of the study offer, ensure quality in international competition and create transparency for international collaboration. In individual Laender, accreditation is a pre-requisite for the state approval of a new study course. The accreditation essentially takes place through peer review. The study courses are evaluated five to seven years after their establishment. For the accreditation of new Bachelor's and Master's study courses, the Standing Conference has initially set up an accreditation council (*Akkreditierungsrat*) for all Laender comprising 14 members.

10. THE RECOGNITION OF DEGREES FROM THE FORMER GERMAN DEMOCRATIC REPUBLIC (GDR)

Following the restoration of the unity of Germany as one state in October 1990, a prime concern of education policy in the Federal Republic has been to establish a common and comparable basic structure in the school system and a common, though differentiated, higher education and academic landscape.

Allgemeine Hochschulreife certificates, which as of the 1990-91 school year and until the year 2000 can be obtained after 12 years (instead of the more common 13) by pupils in four of the five new *Laender*, entitle holders to enter any course of study in German higher education institutions.

The Unification Treaty rules that all examinations passed or qualifications obtained in the former GDR or in the other *Laender* are equal and confer the same rights provided they are equivalent. These include, for example, *Diplom* qualifications obtained from state and state-approved higher education institutions, and qualifications awarded by colleges of art and music, *Fachschulen* and engineering schools, military higher education institutions, and training institutions for technical assistants.

Qualifications which are judged to be of equal level, but not equivalent to qualifications from a university or a *Fachhochschule* derive from courses which were particularly closely connected with the former GDR's economic and social system (e.g. economics, philosophy, sociology, history, cultural studies).

To safeguard freedom of movement in particular and to improve the mobility of teaching staff between the Laender in eastern Germany and the Laender in western Germany, the Standing Conference of the Ministers of Education and Cultural Affairs reached an "Agreement on recognizing teacher training courses in the former GDR and classifying them in accordance with conventional teaching careers in the *Laender* in western Germany" (Resolution of 7/5/1993). In this way the ministers fulfilled the mandate of the Unification Treaty of 1990 (Art. 37, Para. 2) to recognize teacher training completed in the former GDR in line with the criteria laid down by the Standing Conference of the Ministers of Education and Cultural Affairs. In order to implement this agreement the appropriate changes have to be made to civil service law and collective bargaining law.

THE UNITED KINGDOM

Cloud Bai-Yun

The Secretary of State for Education and Skills is responsible for all aspects and levels of education in England, and for university education in Scotland, Wales and Northern Ireland. The Secretaries of State for Scotland, Wales and Northern Ireland are responsible for all non-university education in their countries, and are consulted about university matters there.

Higher education' is defined as study above GCE Advanced level, that is, the GCE A level or Vocational GCE A Level (AVCE) or the Scottish equivalent.

In recent years, particularly The Further and Higher Education Act of 1992 made significant changes within the higher education sector in the UK. Among the main effects of the Further and Higher Education Act of 1992 were:

- The ending of the binary system of higher education by which the 'traditional' universities and the polytechnics were treated separately.
- The abolition of the Council for National Academic Awards (CNAA), leaving the majority of institutions to award their own degrees.
- The creation of Higher Education Funding Councils for England (HEFCE), Scotland (SHEFC) and Wales (HEFCW).

1. HIGHER EDUCATION INSTITUTIONS

Higher education in the United Kingdom is now provided in two types of institutions: universities and colleges of higher education.

1.1 Universities

In the United Kingdom, universities are independent, self-governing bodies, empowered by a Royal Charter or an Act of Parliament to develop their own courses and award their own degrees. Any amendment of their charters or statutes is made by the Crown acting through the Privy Council on the application of the universities themselves. The universities alone decide what degrees they award and the conditions on which they are awarded; they alone decide what students to admit and what staff to appoint. Their standards are maintained by their extensive use of external examiners (particularly in the case of older universities) and the activities of the Quality Assurance Agency (QAA) which reports on universities' teaching and research quality in a rolling four-year programme. The QAA and the external examiner system work to ensure that standards of degrees and degree awards are of the same standard from one institution to another.

The majority of universities, especially the older ones, are active in both teaching and research, though it is possible that in future years some universities may be designated as exclusively research institutions.

The universities of the United Kingdom may be considered as falling into ten main types, as listed, and described, below:

- (1) the universities of Oxford and Cambridge
- (2) the four older Scottish universities
- (3) the University of London
- (4) the University of Wales
- (5) the 'modern' or 'civic' universities (sometimes called 'redbrick' universities)
- (6) the new universities
- (7) the ten new technological universities
- (8) the Open University
- (9) the former polytechnics granted university status by the Further and Higher Education Act, 1992
- (10) the privately financed University of Buckingham

Oxford and Cambridge

The most distinctive feature of these universities is the college system. The colleges are completely autonomous as regards their property, finances and internal affairs, but it is the university which awards degrees and determines the conditions on which they are awarded. Students become members of the university by being admitted as members of their colleges; their studies are largely guided by the senior members of their colleges (generally called 'fellows').

Oxford

Colleges for men and women: *Balliol College; Brasenose College; Christ Church; Corpus Christi College; Exeter College; Hertford College; Jesus College; Keble College; Lady Margaret Hall; Lincoln College; Magdalen College; Merton College; New College; Oriel College; Pembroke College; The Queen's College; St Anne's College; St Catherine's College; St Edmund Hall; St Hugh's College; St John's College; St Peter's College; Trinity College; University College; Wadham College; Worcester College.*

Colleges for women: *St Hilda's College; Somerville College.*

Postgraduate colleges and societies: *All Souls College; Green College* (a medical graduate college); *Linacre College* and *St Cross College* (established in 1962 and 1965 as societies for graduates reading for advanced degrees or diplomas of the University in all subjects); *Nuffield College; St Anthony's College; Wolfson College* (established in 1966, with a special concern for studies in the natural sciences).

Permanent private halls:

Campion Hall: Men only. Established in 1896 for members of the Society of Jesus only, and granted present status in 1918.

Greyfriars: Men only. Established in 1910 and granted present status in 1957. Receives undergraduates for tuition in any school (subject), giving priority for acceptance to student members of all branches of the Franciscan Order.

Mansfield College: Men and women. Founded in 1886 to provide a 'Free Church faculty in theology in Oxford' and a college for the training of non-conformist ministers, mainly of the Congregational Church. Granted present status in 1955. Receives undergraduates for tuition and graduates for tuition or research in any subject.

Regent's Park College: Men and women. Founded in 1810 as the 'Baptist Academical Institute in Stepney' and established in Oxford between 1927 and 1940. Granted present status in 1957. Admits theological students and others wishing to read for the BA degree or higher degrees.

St Benet's Hall: Men only. Established in 1897 for members of the English Benedictine Abbey of Ampleforth, Yorkshire, only. Granted present status in 1918.

Cambridge

Colleges for men and women: *Christ's College; Churchill College; Clare College; Corpus Christi College; Downing College; Emmanuel College; Fitzwilliam College; Girton College; Gonville and Caius College; Homerton College; Jesus College; King's College; Magdalene College; Pembroke College; Peterhouse; Queens' College; Robinson College; St Catharine's College; St John's College; Selwyn College; Sidney Sussex College; Trinity College; Trinity Hall.*
Colleges for women: *Lucy Cavendish Collegiate Society (mature students only); New Hall; Newnham College.*

Graduate institutions: *Clare Hall; Darwin College; St Edmund's House; Hughes Hall; Wolfson College.*

The four older Scottish universities

St Andrews (founded 1411); *Glasgow* (1451); *Aberdeen* (1495); *Edinburgh* (1583).

The tradition of the Scottish universities does not reflect the residential character of the Oxford and Cambridge colleges.

The University of London

The University of London was constituted by Royal Charter in 1836 as a body empowered to examine and confer degrees on students of approved institutions. Until 1900 its work was restricted to these functions, but in administering them it influenced and co-ordinated the activities of the various other colleges of university rank founded from time to time in London (such as Bedford College for Women, 1849).

From 1858 London University degrees, other than in Medicine, were made available for students other than those in certain recognised institutions. The external degrees of the University, which were then instituted, still provide - both in the UK and overseas - an academic award of high standing for part-time students and others who are not enrolled in a university. London was the first university to admit women to its degrees (in 1878).

The University now not only is a teaching as well as a degree-awarding body but it has become a federation which incorporates medical schools associated with hospitals, non-medical colleges (called Schools of the University, e.g. University College and King's College), together with a number of postgraduate and other institutions. Some other higher education establishments in London are also affiliated to the University, and in others ('institutions with recognised teachers') certain members of staff are recognised as teachers of the University.

External degrees

University of London degrees and diplomas are available to external students who study privately in their own time. There are undergraduate programmes in law, management and economics, arts, music and divinity; and postgraduate programmes in distance education, occupational psychology, environmental management, agricultural development, financial economics, financial management, law and geography.

The Universities of Wales

The University of Wales consists of constituent university colleges and a medical school: *University College of Wales, Aberystwyth; University of Wales, Bangor; University of Wales College of Cardiff; University College of Swansea; St David's University College, Lampeter; University of Wales College of Medicine.*

The 'modern' (or 'civic') universities (with dates of foundation)

The civic universities mostly originated in the university colleges set up in large towns and cities in the latter half of the nineteenth century and the early years of the twentieth. Until they became universities in their own right, the colleges offered courses leading to the external degrees of London University. The University of Durham stands a little apart from the rest of this group by virtue of its earlier foundation and because it has a collegiate organisation (but teaching takes place in departments). The 'modern' universities are *The University of Durham* (1832), *The Queen's University of Belfast*, *The Victoria University of Manchester* (1880); *The University of Birmingham* (1900); *The University of Liverpool* (1903); *The University of Leeds* (1904); *The University of Sheffield* (1905); *The University of Bristol* (1909); *The University of Reading* (1926); *The University of Nottingham* (1948); *The University of Southampton* (1952); *The University of Newcastle upon Tyne* (1951); *The University of Hull* (1954); *The University of Exeter* (1955); *The University of Leicester* (1957) and *The University of Dundee* (1967).

The 'new' universities (with dates of foundation)

The 'new' universities were established to meet the need for more university places. Their most distinctive features are that they were empowered from the outset to award their own degrees and that they tried to design courses which break down the conventional departmental structure and enable undergraduates to study in a range of different subject areas with equal specialisation. The 'new' universities are *The University of Sussex* (1961); *The University of Essex* (1961); *The University of Keele* (1962); *The University of York* (1963); *The University of East Anglia* (1964); *The University of Kent at Canterbury* (1964); *The University of Lancaster* (1964); *The University of Warwick* (1965); *The University of Stirling* (1967) and *The University of Ulster* (1984).

The technological universities

The ten new technological universities received their status as a result of the Robbins Report on Higher Education (1963). The University of Strathclyde and Heriot-Watt University were formerly Scottish central Institutions; the others were Colleges of Advanced Technology (CATs). The technological universities are *The University of Aston in Birmingham* (now *Aston University*); *Bath University of Technology*; *The University of Bradford*; *Brunel University* (Uxbridge, Middlesex); *City University* (London); *Heriot-Watt University* (Edinburgh); *Loughborough University of Technology*; *The University of Salford*; *The University of Strathclyde* (Glasgow); *The University of Surrey* (Guildford).

The post-1992 universities (or 'second phase' universities)

The Further and Higher Education Act of 1992 led to the dissolution of the Council for National Academic Awards (CNAA) which validated the degree awards of the then polytechnics. The polytechnics were granted full university status, with the full range of degree-awarding powers. Many of the institutions changed their name to reflect their new status. The 39 institutions affected are listed below, with their former name given in brackets:

Anglia Polytechnic University (Anglia Polytechnic; has applied to be re-named *The University of Eastern England*);

Bournemouth University (Bournemouth Polytechnic);

University of Brighton (Brighton Polytechnic);

University of Central England in Birmingham (Birmingham Polytechnic);

University of Central Lancashire (Lancashire Polytechnic);

London Guildhall University (City of London Polytechnic);

Coventry University (Coventry Polytechnic);

De Montfort University, Leicester (Leicester Polytechnic);

University of East London (Polytechnic of East London);

University of Glamorgan (Polytechnic of Wales);

Glasgow Caledonian University (Glasgow Polytechnic/Queen's College, Glasgow);

University of Greenwich (Thames Polytechnic);

University of Hertfordshire (Hatfield Polytechnic);

University of Huddersfield (Huddersfield Polytechnic);

University of Humberside (Humberside Polytechnic);

Kingston University (Kingston Polytechnic);

Leeds Metropolitan University (Leeds Polytechnic);

Liverpool John Moores University (Liverpool Polytechnic);

Manchester Metropolitan University (Manchester Polytechnic);

Middlesex University (Middlesex Polytechnic);

Napier University (Napier Polytechnic of Edinburgh);

University of North London (Polytechnic of North London);

University of Northumbria at Newcastle (Newcastle Polytechnic);

Nottingham Trent University (Nottingham Polytechnic);

Oxford Brookes University (Oxford Polytechnic);
University of Paisley (Paisley College of Technology);
University of Plymouth (Plymouth Polytechnic South West);
University of Portsmouth (Portsmouth Polytechnic);
The Robert Gordon University (Robert Gordon Institute of Technology);
Sheffield Hallam University (Sheffield City Polytechnic);
South Bank University (South Bank Polytechnic);
Staffordshire University (Staffordshire Polytechnic);
University of Sunderland (Sunderland Polytechnic);
University of Teesside (Teesside Polytechnic);
Thames Valley University (Polytechnic of West London);
University of the West of England at Bristol (Bristol Polytechnic);
University of Westminster (Polytechnic of Central London);
University of Wolverhampton (Wolverhampton Polytechnic);
The *University of Derby* (formerly Derbyshire College of Higher Education) and
The *University of Luton* (formerly Luton College of Higher Education)
The University of Derby and University of Luton are the two colleges of higher education to receive university status following the Further and Higher Education Act, though others are likely to seek it. The *University of Abertay* was formerly the Dundee Institute of Technology.

The Open University

The Open University is a non-residential distance teaching university. It received its Royal Charter in 1969. There are no formal entry requirements for admission to undergraduate courses, which are based on a credit system and are designed for students 'precluded from achieving their aims through an existing institution of higher education'. Teaching is conducted by means of a combination of printed materials, face-to-face tuition, short residential schools, radio, television, audio and video tapes, computers and home experiment kits. The University also offers continuing education courses including in-service training for teachers, updating courses for managers, scientists and technologists, and short courses of community education.

The University of Buckingham

The University was founded as the University College at Buckingham, a privately financed institution which admitted its first students in February 1976. It received its Royal charter early in 1983, and was constituted by the name and style of 'the University of Buckingham'. The University continues to be privately financed and offers two-year courses, each year consisting of four terms of ten weeks, mainly in the fields of law, accountancy, sciences and economics, which now lead to the degree of Bachelor; it is also empowered to award higher degrees.

1.2 Colleges of higher education

Many colleges of higher education also award degrees through their affiliation with a university. It is not possible to list here all the colleges offering courses of higher education. The English colleges listed are confined to those in the Higher Education Funding Council for England sector.

The list of colleges in Wales, Scotland and Northern Ireland includes institutions providing at least one full-time course leading to a first degree granted by an accredited validating body.

2. QUALIFICATIONS

The awards made by higher education institutions may be listed as:

- BTEC/SCOTVEC Higher National Certificate/Diploma (HNC/HND)
- Diploma of Higher Education (Dip.H.E.)
- First degree
- Higher degrees (postgraduate degrees)
- Honorary degrees

2.1 *Higher National Certificate/Diploma (HNC/HND)*

They are qualifications for higher-technician, managerial and supervisory levels. HNCs and HNDs can be taken in many higher education institutions. Courses take one to three years, depending on the level and mode of study.

2.2 *Diploma of Higher Education (Dip.H.E.)*

Higher education institutions may offer two-year courses leading to the Dip.H.E. It is often possible to transfer on to an appropriate degree course on completion of a Dip.H.E., although the qualification is valid in its own right.

2.3 *Foundation Degrees*

Foundation degrees are new employment related higher education qualifications designed to equip students with work related skills. The sectors covered by foundation degrees include:

- Construction
- Creative industries
- E- business
- E-commerce
- Finance
- Information technology
- Law

Foundation degrees have been designed with employers to provide an employment base at associate professional and higher technician level. They are awarded by universities and higher education colleges.

A foundation degree can be used as a starting point for further study, either a related honours degree or further professional development in the workplace.

2.4 First degrees

Names of first-degree awards

Various names are given to the first degrees awarded by British universities. At most universities the first degree in Arts is the B.A. (Bachelor of Arts) degree and the first degree in Science is the B.Sc. (Bachelor of Science) degree. But at the universities of Oxford and Cambridge, and at several new universities, the B.A. is the first degree awarded to students in both Arts and Sciences; the B.Sc. is unknown at Cambridge, but is a higher degree at Oxford. In Scotland the first arts degree at three of the four old universities is the MA. There are several variations on the Bachelor theme, e.g. B.Sc. (Econ.) (Bachelor of Science in Economics), B.Com. (Bachelor of Commerce), B.Soc.Sc. (Bachelor of Social Sciences), B.Eng. (Bachelor of Engineering), B.Tech. (Bachelor of Technology), B.Ed. (Bachelor of Education), L.L.B. (Bachelor of Laws). The first award in Medicine is the joint degrees of M.B., Ch.B. (Bachelor of Medicine, Bachelor of Surgery), the designatory letters of which vary from university to university.

Structure of degree courses

The academic year (30 weeks at most places, 24 at Oxford and Cambridge) is spread over three equal terms. Increasingly, however, academic programmes are being organised into two or three semesters per year; this varies from university to university.

Course structures also vary considerably, not only between but also within universities. The commonest pattern for degree examinations is that they come in two sections: Part I, taken after the first or second year of the course, and Part II ('Finals') taken at the end of the course. In some Scottish universities (see below) the first-degree system differs considerably from that in England and Wales.

Types of degree

Each university decides the form and content of its own degree programmes and examinations. These therefore vary from university to university, as do the names given to the different types of degree awarded. For example, a 'Special' degree at many universities is a Special Honours qualification awarded on satisfactory completion of a Special honours course, involving specialised study in a single subject; at Cambridge, however, a 'Special' is an Ordinary degree, at a much lower level, for non-Honours candidates, taken in several subjects.

The first-degree structure in all British universities is based on the **Honours** degree. Most graduates going on to higher study or employment in the professions, for example, would normally have a good class Honours degree. Successful candidates in Honours degrees are placed in different classes: Class I (a 'first'); Class II, Division 1 (an 'upper second'); Class II, Division 2 (a 'lower second'); Class III (a 'third').

The main categories of Honours degrees are as follows:

- Special Honours: one-subject courses (although relevant subsidiary subjects are often studied as well, at least in the first year or two)
- Joint/Combined/Double Honours: two or more main subjects studied to the same level

- General Honours: two or three main subjects studied, at a lower level of specialisation

At many universities a performance in an honours course that does not warrant the award of third-class honours will earn a Pass degree. Apart from the honours course, there are courses that lead to Ordinary (sometimes called Pass or General) degrees, but these have virtually disappeared.

Aegrotat degrees

Candidates who have followed a degree course but have been prevented by illness from taking the examination may be awarded a degree certificate (without classification) indicating that they were likely to have obtained the degree had they taken the examinations.

Length of degree courses

At most universities, honours and pass courses in arts, social science, and pure and applied science last three or four years, but courses in architecture, dentistry and veterinary medicine usually last five years, and complete qualifying courses in medicine up to six years. Courses in fine arts and pharmacy may last four years. Four-year courses exist mainly in double honours schools, especially when they involve foreign languages and a period of study abroad, and in the technological universities, where some courses include a period of integrated training (sandwich courses).

The Scottish first degree

The distinctive feature of first degrees at some Scottish universities is the Ordinary M.A. course, which has no counterpart in England and Wales, and the Ordinary B.Sc., which both last three years. The function of the Ordinary M.A. is to provide a broad, general education. Scottish undergraduates are required to show during their first two years of study, over a range of subjects, that they are fit to go on to an honours degree course, which takes four years to complete. The level of the Scottish four-year honours course reaches a standard about the same as that of three-year honours courses elsewhere in the UK.

2.5 Higher degrees

These may be:
 some bachelors' degrees (B.Phil., B.Litt., etc.)
 masters' degrees (M.A., M.Ed., M.Sc., etc.)
 doctorate of philosophy (Ph.D. or D.Phil.)
 higher doctorates (D.Litt., D.Sc., etc.).

At Oxford and Cambridge the degree of M.A. is conferred on any B.A. of the University without any further course of study or examination, after a specified number of years and on payment of a fee.

Candidates for a Master's degree at other universities (and, at some, for the degrees of B.Phil., B.Litt. and B.D., which are of equivalent standing) are normally expected to have a first degree, although it need not have been obtained at the same university. Masters' degrees are usually taken after one year (if taught) or after two (if mainly research-based); degrees can be achieved via the equivalent period of part-time study. The Ph.D. normally requires a minimum of three years' original research.

In some universities and faculties students may be allowed to proceed to a Ph.D. course after an initial year of study and/or research common to both a Ph.D. and a Master's degree. Candidates for a Master's degree are required either to prepare a thesis for presentation to examiners, who may afterwards examine them on it orally, or to take written examinations; they may be required to do both.

All Ph.D. students present a thesis; some may be required to take an examination paper as well as being examined orally on their thesis.

Higher doctorates are designated on a faculty basis, e.g. D.D. (Doctor of Divinity), D.Litt. (Doctor of Letters), and D.Sc. (Doctor of Science); candidates are usually required to have at least a Master's degree from the awarding university.

Senior doctorates are conferred on more mature and established workers, usually in recognition of distinguished published contributions to their field.

2.6 Honorary degrees

Most universities confer honorary degrees on persons of distinction in academic and public life, and on others who have rendered service to the university or to the local community. Normally the degree so awarded is not less than a Master's degree.

3. PROFESSIONAL QUALIFICATIONS

3.1 Professional associations

Professional associations vary greatly in size and function. Many qualify people by examination as practitioners in a particular field. Other associations do not conduct examinations for membership but accept the evidence provided by degrees, diplomas or the qualifications of other bodies. Some, which may be called study associations or learned societies, open their membership to amateurs as well as specialists. For this purpose, a 'profession' is that kind of occupation in a special area of activity, and offering a distinctive service, which is followed by persons who have undertaken advanced education and training. People who wish to become members of professional associations must undertake progressive stages of instruction and practical experience before being examined for membership; in qualifying associations there is more than the simple membership structure often found in non-qualifying associations. Admission to 'corporate' membership, that is, to the complete rights and privileges of membership, marks the fact that the candidate has reached, by examination, the degree of competence required of practitioners. Once a member of a professional association, the candidate accepts certain responsibilities to clients, colleagues and the general public. The use of designatory letters after a member's name is usually allowed.

3.2. Qualification

Some associations qualify individuals to act in a certain professional capacity. They also try to safeguard high standards of professional conduct. Few associations have complete control over the profession with which they are concerned. Some professions are regulated by law, and their associations act as the central registration authority. Entry to others is directly controlled by associations which alone award the requisite qualifications (e.g. the Pharmaceutical Society). If

a profession is required to be registered by law and is controlled by the representative Council, a practitioner the Council finds guilty of misconduct may be suspended from practice or completely debarred by the removal of his or her name from the register of qualified practitioners. In other professions the consequences of misdemeanour may not be so serious because the profession does not exercise the degree of control. The professions registered by Statute, and therefore subject to restrictions on entry and loss of either privileges or the right to practise on erasure, are:

<i>Profession</i>	<i>Statutory Committee Controlling Professional Conduct</i>
Architects	Architects' Registration Council
Dentists	General Dental Council
Doctors	General Medical Council
Professions supplementary to Medicine (Chiropodists, Dieticians, - Medical Laboratory Technicians, Occupational Therapists, Orthoptists, Physiotherapists, Radiographers, Remedial Gymnasts)	Council for Professions Supplementary to Medical (separate Board for each profession)
Midwives and Nurses	United Kingdom Central Council for Nursing, Midwifery and Health Visiting
Opticians	General Optical
Patent Agents	Council of the Chartered Institute of Patent Agents
Pharmacists	Statutory Committee of the Pharmaceutical Society
Solicitors	Statutory Committee of the Law Society
Veterinary Surgeons	Disciplinary Committee of the Royal College of Veterinary Surgeons

Certain other professions are closed. Admission to the Bar (barristers) is controlled by the Inns of Court, although their powers have never been confirmed by Statute. Merchant Navy Officers and Mine Managers are certificated by the Department of Trade and Industry and the Health and Safety Executive respectively. No teacher may take up a permanent post in a maintained school in England or Wales unless his or her qualifications have been accepted by the Department for Education and Employment; misconducting teachers are reprimanded, restricted or debarred by the Department, not by the teaching profession. By contrast, there has been some movement towards self-government in the teaching profession in Scotland. Although some types of professional occupation are not controlled by statute, employment in them may nevertheless be fairly strictly controlled by convention. If a particular association is well enough confirmed and if its examinations are respected, employers may require applicants for appointment to certain posts either to have or to take its qualifications.

Study

Some associations give their members an opportunity to keep abreast of a particular discipline or to undertake further study in it. Such associations are especially numerous in medicine, science and applied science. Many qualifying associations also provide an information and study service for their members. Some of the more famous learned societies confer added status upon distinguished practitioners by electing them to membership or honorary membership.

Protection of members' interests

Some associations exist mainly to look after the interests of the individual practitioner and the group. A small number are directly concerned with negotiations over salary and working conditions.

Membership

Qualifying associations have different categories of membership, as listed below:

Corporate Members: these are the fully qualified, constituent members of incorporated associations. They are accorded full rights and privileges and may vote at meetings of the corporate body. Corporate membership is often divided into two grades, a senior grade of 'Members' or 'Fellows' and a general grade of 'Associate Members' or 'Associates'.

Non-corporate Members: these are members who are as yet unqualified or only partly qualified. They are accorded limited rights and privileges but may not vote at meetings of the corporate body. Most associations have a 'Student' membership grade. Students are those who are preparing for the examinations which qualify them for admission to corporate membership. Some associations have 'Licentiate' and 'Graduate' membership grades, which are senior to the 'Student' grade. Graduates are those who have passed the qualifying examinations but lack other requirements, such as age or experience, for admission to corporate membership.

Honorary Members: some associations have a special class of Honorary Members or Fellows for distinguished members or outsiders.

Examinations and requirements

Non-corporate members normally become corporate members by examination or exemption, with or without additional requirements. The level of many final professional examinations is of degree standard. The transition from the general grade of membership to the senior is fairly automatic in some associations (e.g. on reaching a prescribed age), but in others the higher grade is reached only after the submission of evidence of research or progress in the profession. Qualifying examinations are usually conducted in two or more stages. The first stage leads to an Intermediate or Part I qualification, which is at about the standard of GCE A level (or equivalent); the second stage leads to a Final or Part II or Part III qualification, which is at the standard of a degree.

Instruction

Students may obtain instruction by any of the following means:

correspondence courses personal and postal instruction combined with a period of direct pupillage (as, for example, the examinations conducted by the Royal Institution of Chartered Surveyors and Institute of Chartered Accountants) some associations maintain their own schools (e.g. the Architectural Association School and the Law Society's School of Law) courses of direct preparation in universities or colleges of further education.

4. ADULT AND CONTINUING EDUCATION

The term 'adult education' covers a broad spectrum of educational activities ranging from non-vocational courses of general interest, through the acquisition of special skills required in industry or commerce, to degree study with the Open University.

The responsibility for securing adult and continuing education in England and Wales is statutory and shared between The Further Education Funding Councils, which are responsible for and fund those courses which take place in their sector and lead to academic and vocational qualifications; and Higher Education Funding Councils, which fund advanced courses of continuing education, and LEAs, which are responsible for those courses which do not fall within the remit of the funding councils.

Funding in Northern Ireland is through the education and library boards, and in Scotland through the Scottish Office Education and Industry Department.

Providers

Courses specifically for adults are provided by many bodies. They include, in the statutory sector:

- LEAs in England and Wales
- the regional and islands EAs in Scotland and the Scottish Office Education and Industry Department
- education and library boards in Northern Ireland
- further education colleges
- HEIs, especially the Open University and Birkbeck College (University of London)
- residential colleges such as Ruskin College (University of Oxford)
- the BBC, independent television and local radio stations.

The Forum for the Advancement of Continuing Education (FACE) promotes collaboration between HEIs active in this area. The OU, in partnership with the BBC, provides distance teaching which leads to first degrees; it also offers post-experience and higher degree courses. Birkbeck College in the University of London caters exclusively for part-time students. Those HEIs which were formerly polytechnics, by virtue of their range of courses and flexible patterns of student attendance, provide opportunities in the field of adult and continuing education. Many of the redbrick universities also have a long tradition of providing courses for people in their community.

There are also a number of voluntary bodies, of which the largest is the Workers' Educational Association (WEA), operating throughout the UK and reaching about 180,000 adults students annually.

The National Institute of Adult Continuing Education (NIACE) provides information and advice to institutions in England and Wales on all aspects of adult continuing education. NIACE conducts research, project and development work, and is funded by the DfEE, the LEAs and other funding bodies. The Welsh committee, NIACE Cymru, receives support from the Welsh Office, support in kind from WJEC, and advises government, voluntary bodies and education providers on matters relating to adult continuing education. In Scotland such advice is supplied by the Scottish Community Education Council. The Northern Ireland Council for Adult Education has an advisory role.

Membership of the Universities Association for Continuing Education (UACE) is open to any university or university college in the UK. It promotes university continuing education, facilitates the exchange of information, and supports research and development work in continuing education.

Courses

Although lengths vary, most courses are part-time. Long-term residential colleges in England and Wales are grant-aided by FEFC and FEFCW, and provide full-time courses lasting one or two years. Some colleges and centres offer short-term residential courses lasting from a few days to a few weeks in a wide range of subjects. LEAs directly sponsor many of the colleges, while others are sponsored by universities or voluntary organisations.

5. ADMISSION

Universities usually have a general minimum requirement for admission to a degree course (matriculation), and special, higher requirements may be in force for particular courses. (These requirements are sometimes waived for people with non-standard educational backgrounds, such as adult returners and those who have followed access courses.) The requirements are often expressed in terms of subjects passed at A level (or its equivalent), in terms either of grades (e.g. BBC) or of points (where an A level grade A is worth 10 points, grade B eight points, grade C six points, and so on).

Applications to first-degree courses are handled through a central clearing house, the *Universities and Colleges Admissions Service (UCAS)* - see Useful Addresses).

The Open University

No formal educational qualifications are necessary for admission to first-degree courses. However, students who have successfully completed one or more years of full-time study at the higher level (or its equivalent in part-time study) may be eligible for exemption from some credit requirements of the BA degree.

Business schools

The degrees awarded by the various University Business Schools are postgraduate and therefore normally require an honours degree as part of their criteria for admission.

6. ENGLISH LANGUAGE

6.1 English language examinations

Courses leading to examinations and qualifications in English for speakers of other languages are offered in both public and private sector institutions.

The accreditation of schools and the validation of their English language programmes is undertaken by the Accreditation Unit of the British Council. There are separate schemes for the public and private sectors: the English Language Schools Recognition Scheme for the private sector, and the Courses Validation Scheme for the public sector.

There are also two professional bodies in this area: ARELS (the Association of Recognized English Language Schools) for the private sector, and BASCELT (the British Association of State Colleges in English Language Teaching) for the public sector. Both organisations issue an annual brochure that gives details of member institutions and the courses available.

The British Council, jointly with UCLES and the IDP Education Australia, manages a test of academic English called the **International English Language Testing System (IELTS)**. This has superseded ELTS (the English Language Testing Service). The test is a systematic assessment of the English-language performance of non-native speakers who wish to study or train in the medium of English. It is offered once a month normally, but more frequently at peak times of demand. There are test centres in around 100 countries (details available from the local British Council office), including 22 centres in the UK. A booklet containing sample materials, with an accompanying cassette, gives detailed information on the format of the test, its content and operation; it is available for a small charge from local test centres and from the Publications Department of UCLES.

6.2 Entrance requirements for higher education

Universities often require evidence of English-language proficiency from overseas students who wish to study in the UK, particularly if the medium of instruction in their previous education has not been English. The most recent published information setting out these requirements is in two British Council books: *1996-98 Access to UK higher education: A guide for international students* and *English Language Entrance Requirements in British Higher Education* (1994). Students from overseas who intend to study in the UK should make direct contact with the university or department they wish to apply to.

7. QUALITY ASSURANCE

The term 'quality assurance' refers to the totality of systems, resources and information devoted to maintaining and improving the quality and standards of teaching, scholarship and research, and of students' learning experience.

British universities and colleges take quality and standards very seriously. British higher education has quality assurance arrangements of unrivalled coverage, sophistication and rigour. This is not a reflection of worries about quality and standards but an indication of the importance which British institutions, and those who fund and supervise them, attach to protecting quality and standards, and of being seen to do so. It is also part of a national drive to secure educational standards at all levels.

In the United Kingdom institutions seeking permission to award degrees are required to demonstrate that they have a commitment to quality assurance and adequate systems for safeguarding academic standards. Institutions wishing to use the title *University*, must be authorised to award both taught and research degrees. The Government is advised on these matters by the Quality Assurance Agency for Higher Education (QAA). Higher education in the UK is subject to five main forms of quality assurance:

- institutions' own internal quality assurance processes
- academic quality audit (hitherto undertaken by the Higher Education Quality Council: the new Quality Assurance Agency for Higher Education took over this function from 1 August 1997)
- quality assessment (hitherto undertaken separately by the three higher education funding councils for England, Scotland and Wales: the QAA has taken over the delivery of the assessment process from 1 October 1997, except in Scotland (but the funding councils retain the legal responsibility for ensuring that quality is assessed.)
- professional accreditation of vocational and professional subjects (undertaken by a range of professional and statutory bodies)
- the research assessment exercise (undertaken jointly by the three higher education funding councils)

All UK universities and colleges have been audited since 1991 and a fresh round of such audits has now begun. This new round, of audit has changed its focus and is now looking both at the more general question of how individual institutions discharge their obligations, responsibilities for the academic standards and quality of their programmes and awards, and at the evidence they themselves are relying on for this purpose.

UNITED STATES OF AMERICA

Stephen Hunt

1. COUNTRY PROFILE

Postsecondary education in the United States comprises all education that follows the award of a secondary school leaving certificate (High School Diploma or GED Certificate). The term “postsecondary education” is generally defined as including all education beyond secondary school, including both vocational preparation as well as academic and professional studies. “Higher education” is generally understood to refer to that portion of postsecondary education that awards academic and professional degrees and the institutions that do so.

The postsecondary educational system in the United States consists of the following broad type of institutions:

1.1 Postsecondary vocational schools

Postsecondary vocational schools generally offer short courses in occupationally specific subjects at less than degree level. In some cases this level of education is offered by institutions that also award degrees in other subjects. These institutions use a variety of names and generally award certificates or diplomas for the completion of training courses. Many of them specialize in a single occupational field. Some of the programmes may result in transferable credits if the subject is appropriate for further study and the study programme is educational in character rather than training.

The following types of institutions award degrees and are considered institutions of higher education:

1.2 Community and junior colleges

Community colleges are public institutions that offer courses at the postsecondary vocational level as well as at the associate degree level. Associate degree studies are available in both academic and professional subjects, with the academic track intended to prepare students to transfer into a bachelor’s degree programme and the professional track preparing students either for immediate employment or for transfer to a bachelor’s degree programme in the same subject, where that exists. Junior colleges are generally private institutions that offer the associate degree. Their educational mission is similar to that of community colleges at the degree level. Community and junior colleges are teaching institutions and do not conduct much research, although individual faculty may do so, especially in collaboration with local employers.

1.3 Four-year colleges and comprehensive institutions

Four-year colleges, often called liberal arts colleges, are institutions that offer courses leading to the bachelor's degree in a wide variety of subjects. Comprehensive institutions offer courses leading to the bachelor's degree and master's or first-professional degrees, but not the research doctorate. Either type of institution may also offer short programmes leading to associate degrees or to certificates or diplomas. The subject matter offered includes both the academic disciplines and professional fields. Because institutional terminology is not legally protected, institutions in these categories may call themselves "colleges," "universities," or other names. They are distinguished in the United States by what they offer and at what level, not by what they are called. Four-year colleges and comprehensive institutions concentrate on teaching activities and do not usually conduct much research, although there may be individual faculty who do so.

1.4 Universities

Universities are institutions that offer degree programmes up to and including the research doctorate in a variety of disciplines and fields of study. Such institutions generally conduct original basic research and development activities as a significant part of their operations, and faculty (as well as graduate students) are usually expected to devote time to research projects and to become recognized contributors to their disciplines or fields. Teaching is also emphasized, especially at the undergraduate degree levels, but is balanced with the commitment to research. A third university mission is public service, which is usually discharged via research, consulting, and outreach activities provided for the community, state, or region that the institution serves. The term "university" is not legally protected, so doctorate-granting institutions may use other titles such as "institute" or "college." The important consideration is the highest degree awarded and the research mission, not the term used in the name of the institution.

1.5 Specialized institutions

Specialized institutions are degree-granting institutions that offer courses in only one or a few closely related fields, or that prepare all students for similar professional careers. Examples include schools concentrating in engineering, law, business, health professions, theological seminaries, schools of art and music, and service academies preparing military officers. Specialized institutions may offer any combination of degrees from associate to the research doctorate. A wide variety of titles are used by specialized institutions, such as "academy," "conservatory," "school," "institute," "college," "union," and others.

1.6 Non-traditional institutions

The U.S. educational system features many institutions in the above categories that provide education via non-traditional means, such as correspondence education, distance education, the Internet, on-site cooperative programmes with employers, experimental curricula or structures, programmes designed for older or employed students or part-time students, and transnational education (overseas branches, cooperative partnerships, franchises, or independent institutions). These non-traditional programmes may be offered by traditional institutions in addition to their regular programmes, or they may be offered by institutions that specialize in non-traditional education. Many such institutions have sought and earned accredited status and are now regular and recognized educational providers, while others have either deliberately remained outside the recognized system or have failed to qualify for inclusion.

2. CHARACTERISTICS OF DIPLOMAS

The United States uses the term “degree” to refer to an academic or professional award in the traditional academic or professional sense: the terms “certificate” and “diploma” refer to awards granted for shorter and more specialized programmes. Degrees, diplomas, and certificates may be awarded at the “undergraduate” or “graduate” levels. Undergraduate awards are those granted for the completion of work leading to an academic or first-professional degree. Master’s or research doctorate degree plus certificates of advanced study and certain other specialized awards are called graduate awards (the same as post-graduate awards in British English).

2.1 Undergraduate awards

Vocational certificates or diplomas may be awarded by postsecondary vocational institutions or by other institutions for the completion of short, non-degree training programmes in specific occupations below the level of a first degree. These programmes commonly take between a few weeks or a semester and 1-3 years, depending on the complexity of the training requirements for the occupation. While it is possible to earn academic credit for some vocational training or portions thereof, recognition of this credit at higher levels is up to the discretion of the admitting college or university and usually depends on both its quality standard and its relevance to what the student proposes to study.

Associate degrees are awards granted for completing structured two-year programmes of study in either academic or professional subjects. Academic associate degrees are intended to prepare students for possible transfer into a bachelor’s degree programme in the arts, sciences, social sciences, or humanities. Professional associate degrees are awarded for completing programmes of study prescribed by the accrediting or licensing bodies that govern the professions that recognize educational qualifications at this level. It is usually possible for holders of professional associate degrees to continue their studies, if qualified, in the same field at the bachelor’s degree level. Many colleges and universities have transfer agreements, called articulation agreements, with associate degree programmes and institutions. These agreements permit qualified students with good records to transfer to a bachelor’s degree programme and have their associate degree credits accepted as satisfying a portion of the requirements for the higher degree. Some professional associate degree programmes have no higher counterpart and some portions of associate degree professional programmes that are purely occupationally oriented do not represent recognizable academic work. These so-called terminal associate degree programmes and courses do not permit the graduate to transfer credits to a higher degree programme. As always, recognition of credit is at the discretion of the admitting institution to which a student applies.

Bachelor’s degrees are awards granted for completing structured programmes intended to last four or five full-time academic years, depending on the subject, and that involve supervised concentration in one or more subjects. U.S. bachelor’s degrees may also involve the preparation of supervised research papers, independent study, comprehensive subject examinations, and supervised field experiences or internships, especially if the degree is part of an honors programme. Bachelor’s degrees in academic disciplines and some professional fields are designed to require four full-time academic years to complete. Professional bachelor’s degree in some engineering specialties, health professions, and architecture require five full-time academic years to complete.

Undergraduate or Post-Baccalaureate Certificates and Diplomas are awarded for the completion of short, specialized study programmes in subfields. They are often related to an individual's degree and completed in the summer or semester following that degree or together with it. Examples of such certificates and diplomas include, but are not limited to: fulfilling the requirements for school teacher certification in the concentration subject of one's bachelor's degree; qualifying for special competence in a foreign language; or qualification in a computer software application on programming.

2.2 Graduate awards

Graduate awards in the United States include the higher first degrees that require prior possession of an undergraduate degree, advanced degrees, plus certificates or diplomas indicating completion of specialized advanced studies.

First-professional degrees are a group of recognized degrees awarded in professional subjects that (a) require that the student have previously earned an undergraduate degree (not necessarily in the same field); (b) that serve as one of the necessary steps to qualifying to practice a licensed profession at entry level; and (c) represent the first degree in that professional field, not advanced study or research. Recognized first-professional degrees include the first degrees awarded in chiropractic, dentistry, law, medicine, optometry, osteopathy, pharmacy, podiatry, theology (for ordination), and veterinary medicine. These degree awards are sometimes called "doctor of..." and may permit the holder to style himself or herself as "Dr.," but they are not research doctorates in these fields. In all of the first-professional fields it is possible to earn research master's and doctoral degrees after the first-professional degree.

Master's degrees represent either structured professional education programmes similar to the "taught" master's degrees in other educational systems or research degrees. Professional master's degrees generally involve independent study and the preparation of supervised reports on applied research or problem exercises in addition to coursework, seminars, and comprehensive examinations. An example is the MBA in business administration. Academic research master's degrees involve the preparation of an independent research thesis as well as coursework, seminars, and comprehensive examinations, and are similar to the "research" master's degrees in other education systems. The duration of most master's degree programmes, professional or academic, is usually two years. Well-prepared students who have earned recognized advanced credit may be able to complete a degree programme in one or one-and-a-half years. Part-time students may take longer. Some professional master's degrees may vary in length depending on whether the student already holds an undergraduate degree in the same field.

Certificates and Diplomas of Advanced Study are awards that signify completion of concentrated short programmes at the graduate level in specialized fields where a full degree is not considered necessary or appropriate. Such programmes usually last a semester or sometimes an academic year and are often tailored to the student's individual needs. Graduate-level certificates and diplomas are frequently awarded in subjects such as cultural area or period studies, education specializations, technological or scientific applications, and business specializations.

Research doctorate degrees are the highest academic degree level awarded in the United States. The most common such award is the Doctor of Philosophy or Ph.D., but there are other recognized awards at the same level that have different names, such as the Doctor of Juridical Science (SJD or JSD) in law, Doctor of Public Health (DPH), Doctor of Theology (ThD), Doctor of Education

(EdD), Doctor of Business Administration (DBA), and others. Common to all U.S. research doctorate programmes, in all academic disciplines and applied research fields, is the preparation and public defense of a major original research paper called a dissertation. The dissertation is expected to be of publishable quality and to either make an original contribution to knowledge or help advance the discipline or field by synthesizing existing knowledge in a creative, original way to address a major research problem. It is the core of the doctoral study programme and the focus of the entire programme. Prior to work on the dissertation the student is expected to have completed a series of advanced seminars in one major and usually two or more minor concentrations, and to have sat a battery of oral and written comprehensive examinations demonstrating broad mastery of the chosen discipline or field of study. Many universities also require doctoral candidates to undergo supervised training in teaching at the college and university levels and to complete internships or conduct field research studies as appropriate. The duration of research doctoral studies varies by subject, by whether prior completion of a master's degree is required, and by how long an individual student's dissertation research takes. Normal durations range between 5-9 years of full-time study following a bachelor's degree.

The United States does not offer a so-called higher doctorate, as do some other education systems. Sustained distinction, research publication, and other accomplishments in a field are recognized in other ways, such as the granting of academic tenure (lifetime professorial contracts) to faculty, election to fellowship status in professional societies, national and international awards for research and practice, and the conveying of honorary degrees and titles.

3. DISCIPLINES AND FIELDS OF STUDY

U.S. higher education offers instruction and research opportunities in all of the traditional disciplines in the arts, humanities, social sciences, and sciences as well as the professional fields. In addition, higher education and research in the United States has moved decisively in the direction of inter- and multi-disciplinary studies and has seen the creation of a number of new subject fields in recent years, especially in the natural and applied sciences but also in the humanities and social sciences. It is a feature of U.S. higher education that students and faculty are actively encouraged, and sometimes required, to become familiar with subjects outside their concentration, especially if these relate to, or reinforce, understanding of the main subject. Other education systems, especially those where interdisciplinary study or the study of different subjects is not traditional, sometimes misunderstand this practice and misinterpret the broad requirements of U.S. degree programmes as "watering down" the concentration or as representing secondary-level work. This is not an accurate view. If students have to undertake remedial studies to make up for poor preparation, this work is clearly indicated as remedial on student records and is not usually awarded credit toward their study programme. The so-called "liberal" or "general" studies requirements at the undergraduate level, and the "minor" or "related field" requirements at graduate level, are intended to ensure that graduates become familiar with the broad context of how their subjects relate to the wider intellectual world and to enable them to work competently with researchers and professionals from other disciplines.

Unlike many countries, the United States does not have national laws, regulations, or authorities that set curricula or that designate what subjects may be taught at a given level or for a given degree. Degree requirements and the syllabi of courses and examinations are set by the faculty in each subject at each institution. In many academic fields, and most professional fields, the faculty are heavily influenced in this process by professional and research bodies that set standards and by the accepted practice and most recent research in a subject. If a professional field of study leads to qualification for a state license, then the content of the first (qualifying) degree in

that field is likely to reflect the knowledge requirements of state licensing bodies. There are presently a tremendous variety of study subjects at all levels including the traditional academic disciplines, the recognized professional fields, and various interdisciplinary specializations and combinations.

4. ISSUANCE OF DOCUMENTS

U.S. award documents generally provide the title of the certificate, diploma, of degree awarded; the name of the institution awarding it, the date of award, and the name(s) of the institutional officials certifying the award. Sometimes the subject studied is also specified if it is not named in the degree title. The names of any previous institutions attended will not be mentioned.. If the student earned the degree through a branch campus or distance location rather than the parent campus, this will not usually be indicated unless the branch is separately accredited as a free-standing entity and awards the degree in its own name. Evidence of a branch location may occasionally be hinted at by reference to the location at which the award was made (such as “ in the city of ...”).

Detailed information about the content of the graduate’s study programme is provided via a document called a transcript. The transcript includes a listing of all courses, seminars, and other structured modules completed and the grades earned; all independent research requirements completed (theses, dissertations, etc.); comprehensive examinations taken; and the credit hours earned for all the aspects of the programme. Most transcripts also include an explanation of the institution’s grading system and a notation stating the degree or other award earned and the date it was completed. Official, authentic transcripts are signed by the registrar of the institution and usually include authenticating features such as seals and watermarks.

U.S. academic and professional award documents do not, by themselves, qualify an individual to practice a profession or hold specific teaching or research rank. Professional license credentials are issued separately by the state of the employer and usually require the completion of other requirements besides earning a degree. Teaching and research ranks are assigned by the institution or organization hiring an individual, and promotions to higher ranks are determined by recommendation of the individual’s peers in the faculty as well as by assessment of the institution’s head and its overseers (board).

5. GRADING SYSTEMS

The most commonly used grading system in U.S. postsecondary education is the so-called four-point scale. Under this system student work is evaluated and given a decimal fraction score ranging from 0 to 4.0, with 4.0 being the highest mark. Four-point systems are often translated into letter grades (the other most popular system) by having 2.0 correspond to a C; 3.0 to a B, etc. Some institutions still use a three-point scale which follows the same principle. In some types of academic work grades are sometimes not given and the student is graded on a “ pass/fail” basis. Some institutions also do not give grades as a matter of policy and substitute detailed written evaluations and critiques by faculty. In the latter cases it is often possible to get the institution to translate the evaluation reports into a letter grade if this is necessary.

Undergraduate students are usually considered to be meeting minimal standards, and thus allowed to remain in school and receive assistance, if their grades average a “C” or 2.0. A “C” is the lowest generally accepted passing mark. The grade of “D” (1.0-2.0.) is technically not failure but (“F”) is marginal and insufficient to permit students to remain in a programme unless the grade is improved. Most graduate students are required to maintain at least a “B” average (3.0) to remain in good standing, and doctoral students are usually required to maintain an “A” average (3.5 or higher).

6. INTERNATIONAL RECOGNITION OF DIPLOMAS

Under United States law and practice, the competent authority in the recognition of credentials earned outside the U.S. educational system is the admitting institution, if an individual is seeking credit for the purpose of enrolling in or completing a study course; and the hiring employer, if an individual is seeking recognition for purposes of gaining employment. In the case of some licensed professions, the state licensing agency is also a competent authority. Many institutions, employers, and licensing bodies rely on what are called credential evaluation services to make recommendations to them concerning the comparability of foreign qualifications to U.S. equivalents. Credential evaluators are professional experts in international education who assess both U.S. and non-U.S. awards.

There is no higher authority to which to appeal decisions by these competent authorities. The U.S. federal government has no power to intervene in, or overturn, academic decisions by educational institutions. It is possible to try to resolve a dispute through the law courts, but this route is both expensive and unlikely to result in overturning the decision of a university admissions office or a personnel office or licensing board. U.S. courts are historically reluctant to substitute their judgment for that of expert faculty, professional examiners, or hiring officials.

The United States actively cooperates in international efforts to improve the understanding of education systems, mutual recognition of qualifications, and the promotion of student mobility. It is a signatory of the Lisbon Convention on the Recognition of Qualifications Concerning Higher Education in the European Region, one of the UNESCO network of recognition conventions. The U.S. Network for Education Information, USNEI, is the U.S. national education information center created under the auspices of the Lisbon Convention. In addition, the United States cooperates with other UNESCO regions, such as the Asia-Pacific Region, and with other international organizations such as the OECD, APEC, and ASEAN. Educational recognition is also an issue addressed in multilateral trade agreements to which the United States is a party, such as NAFTA and GATS.

7. ACCESS TO POSTSECONDARY AND HIGHER EDUCATION

The requirements for admission to postsecondary education are nearly the same in the United States for U.S. citizens and noncitizens. Every undergraduate applicant must possess at least a U.S. High School Diploma or the equivalent as determined by the admitting institution (usually more than the basic requirements), and must have fulfilled any other requirements that the admitting institution imposes (such as examination, standardized tests, copies of previous diplomas and academic records, letters of recommendation, etc.). Graduate applicants must do the same things except that they must show that they possess the required prior degree rather than a high school diploma. Once all of the admissions documents are collected in an applicant’s

file, institutional administrators and faculty evaluate each applicant's record against all of the others for the same programme and select those who, in their professional judgment, should be offered admission. Since most prospective students understand this process and therefore apply to more than one institution, colleges and universities usually accept more applicants than will actually enroll.

Special admissions requirements may be imposed on applicants to certain professional programmes such as theology, the visual and performing arts, or military academies. Theological applicants must usually demonstrate their qualification to meet the nonacademic requirements for ordination in the faith community they seek to serve. Military academy applicants are restricted to U.S. citizens and applicants from other countries are accepted only on a reciprocal basis with their defense forces, and must in any case meet medical and psychological requirements in addition to qualifying academically. Applicants in the visual and performing arts will usually need to provide portfolios of work for evaluation or undergo auditions. Applicants intending to concentrate in some subjects, such as engineering, or prepare for eventual admission to professional programmes such as medicine, may face special requirements for advanced proficiency in related subjects (mathematics, science, etc.).

Some general requirements are made of international applicants that are not made of U.S. citizens. First, they must sit and pass a written test in English usage (called the Test of English as a Foreign Language, or TOEFL) if their native language - or the language of instruction used in their country - is not English. Second, international applicants must qualify for either a student visa or an exchange visa (depending on the programme under which they come to the United States). The United States does not operate a *numerus clauses* system, but there are programmes, especially in some of the professional fields, that are exceptionally difficult to enter because of their popularity.

As in other countries, U.S. institutions have tried to accommodate the needs of nontraditional students, including adult learners. Most institutions will evaluate the academic histories and work experience of adult applicants and recognize credit where this is possible, and they will also evaluate handicapped applicants without prejudice. U.S. institutions possess wide discretionary powers that permit them to review the whole record, treat each applicant as an individual case, and make exceptions when their professional experience indicates that is the right course of action.

8. SEQUENCE AND DURATION OF STUDIES

8.1 Duration of study

Information about the typical duration of studies at different degree levels is provided above under the description of each diploma.

8.2 Sequence of studies

The sequence of studies generally follows the levels indicated above under "The Postsecondary Education System" and "Characteristics of Diplomas." The only major exception is in the case of some disciplines where it is now common to proceed directly to doctoral studies after the bachelor's degree. In these cases the length of the doctoral study is often longer than it would otherwise be. The decline in the importance of master's degrees in such subjects is usually a consequence of there no longer being a useful employment outlook for individuals who do not

possess a research doctorate, and therefore it makes more sense to proceed to study for the higher degree at the outset.

8.3 Academic year

Most U.S. institutions follow a semester calendar in which the academic year, generally nine months, is divided into two units of time. The fall semester begins in either late August or September and ends in December. The spring semester actually begins in winter in January and ends in May or June. There is usually a summer break of approximately three months which is occupied by an optional summer term, and a winter break in late December/early January that may also be occupied by optional short academic experiences.

A few U.S. institutions operate on trimester or quarter calendars.

9. TYPES OF INSTRUCTION

Each institution, and each faculty department or unit within institutions, is free to use the instructional approach it deems best, as are individual faculty who teach individual courses or seminars. In a few cases a standard method of instruction may be imposed by the requirements of a profession or an accrediting association, but these are comparatively rare. Some general types of instructional method are described below.

9.1 Lectures or “taught” courses

The lecture approach is used in many introductory courses and in courses where the instructional goal is to cover a content area and present factual material and established concepts or theories. In the United States, however, even lecture courses involve considerable interaction between faculty and students in the form of dialogue, questions and answers, and invited interruptions. The concept of a passive, respectful student audience digesting the wisdom of an undisputed professor is foreign to most American classrooms. Learning is always considered a common journey shared by faculty and students, and mutual participation and learning from one another is expected and honored.

Most lecture courses involve extensive outside reading; one or more research papers; tests and a final examination; and possibly other assignments depending on the nature of the subject.

9.2 Seminars

Seminars are intensive, highly participatory group studies of a subject or theme guided by a faculty member. Students are expected to participate intensively in seminar discussions and to share progress on their research projects. Most seminars expect students to learn from one another and to complete extensive research projects, usually presented to the seminar as papers of publishable quality. Seminars are usually offered to advanced students after they have completed extensive undergraduate or graduate work in a subject. An exception to this pattern is the proseminar, which is a seminar offered to beginning graduate students in some fields (usually beginning doctoral students) and designed to introduce them to the process and method of advanced study in the field and permit them to select research concentrations.

9.3 Colloquia

Colloquia are intensive group studies similar to seminars but that occur across disciplines and are designed more to share the latest research and findings, or address a common research problem, than to polish research competence in a single field. Advanced graduate studies frequently involves colloquia due to the increasingly interdisciplinary and team-based organization of research.

9.4 Practical exercises

Students at all levels of higher education will find themselves participating in required or elective study experiences designed to enable them to master techniques and methods. These practical exercises are things like art or design studies, scientific laboratory work, performing arts coaching and practice sessions, methodological and research design courses, field trips, supervised teaching practice, etc. The student is expected and required to master theory, factual knowledge, and application in order to become a competent expert in his or her chosen field of study.

9.5 External experience

Many academic disciplines and most professional fields of study require students to complete internships or other forms of supervised and evaluated work experiences as part of both undergraduate and graduate degree programmes. These experiences serve to introduce the student to the professional work environment; help faculty and prospective employers assess his or her fitness for professional level employment; and permit the student to learn how to apply what has been learned in an academic setting to the solution of real life problems.

9.6 Independent study

In many fields of research the topics chosen by students for degree examinations and theses or dissertations are very specialized and not covered by standard courses or seminars. This is particularly true in cases where the subject is interdisciplinary in nature. Independent study arrangements, under the supervision of the faculty adviser, are often developed to enable students to concentrate on a special topic and receive academic credit in such situations. Most independent study requires the successful completion of research papers or projects and may also require the passing of special examinations, either written or oral. Independent study is required of students enrolled in research master's degree and doctoral programmes and constitutes the major focus and time element of those programmes.

9.7 Non-traditional study arrangements

The United States has been, and continues to be, a leader in developing and implementing new methods of educational delivery. Among these are correspondence; distance learning via television, radio, and computer; video; interactive software applications; programmes provided at employer work sites, community facilities, and private residences rather than on campus; programmes delivered by education and training contractors, both academic and nonacademic; and others. Many of these nontraditional methods have been developed to make educational opportunities more accessible to working adults, homebound adults, and persons living in remote locations. Both individual courses and entire degree programmes are frequently provided via nontraditional means. Such methods are considered legitimate and are considered to provide

quality equivalent to traditional methods so long as the providing institution or entity is properly accredited and the programme is approved by the appropriate professional association.

10. DIPLOMAS AND PROFESSIONAL COMPETENCE

The degrees awarded in the United States are: Associate of ... (title), Bachelor of ... (title), Master of ... (title), Doctor of ... (title), and certain professional first degrees specific to particular professions and having regulated titles.

Degrees awarded for academic study in the subject disciplines signify the attainment of a certain level and standard of competence in the knowledge base and research associated with the subject and enable the degree holder to qualify for entry-level work positions for which that degree is a prerequisite. Degrees awarded for study in professional fields accomplish the same results and also, in cases where the profession is regulated and licensed, provide one of the necessary proofs of eligibility for licensee as a practicing member of the profession. (In no case is the attainment of the degree by itself sufficient to permit someone to practice a profession—other steps are also required including examinations, supervised practice, and periods of apprenticeship).

United States institutions may also award certificates and diplomas for short courses of less than degree standard. In some cases certificates and diplomas awarded for occupational subjects below the level of the bachelor's degree may be considered the equivalent of associate degrees in those subjects, particularly if they require at least two years of study.

11. ACCREDITATION, ASSESSMENT, RANKING

U.S. educational institutions are required to be accredited by a recognized association in order to receive public funds and to have their graduates accepted into advanced education programmes, licensed as practicing professionals, or hired by reputable employers. Accreditation is a voluntary process of quality assurance regulated by the institutions and professional associations, but it is also a legally protected process that leads to national recognition. An institution that possesses current accreditation by a recognized accreditation association is considered to be a recognized institution. Nonaccredited institutions may be granted provisional recognition if they have been accepted by a recognized accrediting association as a candidate for accreditation.

Accrediting associations regularly perform on-site inspections and assessments of the quality of the institutions and programmes that they accredit. These assessments are generally carried out every 5-10 years depending on the nature of the programme or institution being accredited. Periodic reassessment occurs as long as the institution or programme remains accredited. Professional programmes and degrees are regulated through the professional accrediting associations and the professional associations and state licensing authorities with which they are affiliated.

Institutions are also required to be chartered, or licensed, to operate within the state where they are legally headquartered. States vary in the degree and frequency of inspection and assessment that they perform on institutions operating within their jurisdictions, and their authority in most cases does not extend beyond their borders. For this reason accreditation is normally taken as the standard of national recognition.

U.S. institutions are legally autonomous and are the legal competent authorities for all matters concerning academics. There is no national governmental regulation of institutions, subjects, faculty, students, or degrees. U.S. law permits institutions to be chartered and operate as either public or private entities and makes no distinction or preference as to type of ownership or control. Public institutions are internally self-governing, as are private institutions. Both U.S. law and policy encourage diversity and autonomy in the nature, types, and methods of education.



C. Directory of Co-authors

DIRECTORY OF CO-AUTHORS

Armenia

Mrs. Karine Danielian
 Counsellor of the International Organization Department of MFA
 General Secretary a.i. of Armenian National Commission for UNESCO
 2 Government Building, Republic Square, Yerevan 375010
 Republic of Armenia

Australia

Prof. Leo West
 Consultant in Higher Education
 24 Jackson Street, St. Kilda
 Clayton, Victoria 3168, Australia

Brunei Darussalam

Dr. Diana Cheong
 Director, International Office
 Universiti Brunei Darussalam
 Bangdar Seri Begawan Gadong 2028
 Brunei Darussalam

Cambodia

Mr. Pich Sophoan
 Director-General
 Directorate General of Higher Education and Technical Vocational Education and Training
 #3 Russian Federation Blvd.
 Phnom Penh, Cambodia

China

Prof. Bie Dunrong
 Graduate School of Education,
 Huazhong University of Science and Technology
 1037 Luoyu Road, Wuhan 430074, P.R.China

India

Prof. Jandhyala B G Tilak
 Senior Fellow and Head, Educational Finance Unit
 National Institute of Educational Planning and Administration
 17-B, Sri Aurobindo Marg
 New Delhi 110016, India

Indonesia

Dr. Satryo Soemantri Brodjonegoro
 Director General of Higher Education
 Ministry of Education and Culture
 Jalan Pintu Satu - Senayan, Jakarta 10270
 Indonesia

Iran

Mr. Abdolmajid Eskandari
Deputy Director General
Office of International Relations
University of Tehran, Enghlab Avenue, Tehran, Iran

Japan

Dr. Akira Arimoto
Director and Professor
Research Institute for Higher Education
Hiroshima University
2-2 Kagamiyama, Naka-ku, Higashi, Hiroshima 739-21, Japan

Korea

Dr. Hyun-Chong Lee
Secretary-General
Korean Council for University Education
27-2 Youido-dong, Yongsungpo-gu, Seoul 150-742
Republic of Korea

Lao PDR

Mr. Phob Phannolath
Head of Foreign Language and Social Science Unit
Faculty of Engineering and Architecture
University of Laos
Ministry of Education
P.O. Box 3166 Vientiane, Lao PDR

Malaysia

Dr. Mohamed bin Suleiman
Chairman, National Accreditation Board (LAN)
14th Floor, Block B, Menara PKNS-P.J.
No.17, Jalan Yong Shook Lin
46050 Petaling Jaya, Selangor Darul Ehsan, Malaysia

Myanmar

Mr. Khin Maung Tint
Deputy Director General (Training)
Ministry of Education
Ministers' Office Compound, Theinbyu Street, Yangon
Myanmar

New Zealand

Ms. Jo Doyle
Senior Policy Analyst
New Zealand Qualifications Authority
PO Box 160, Wellington, New Zealand

Philippines

Ms. Amelia A. Biglete
 Director IV
 Commission on Higher Education-National Capital Region (CHED-NCR)
 6th floor, Pacific Corporate Center
 131 West Avenue, Quezon City, Philippines

Russia

Dr. Victor Chistokhvalov
 Director, Center for Comparative Educational Policy, Ministry of Education of the Russia
 c/o Commission of the Russian Federation for UNESCO
 Ministry of Foreign Affairs
 9 Vozdvijenska Str., 121019 Moscow
 Russian federation

Singapore

Dr. Lana YL Khong
 Professor, Policy and Management Studies Academic Group
 National Institute of Education
 Nanyang Technological University
 1 Nanyang Walk, Singapore 637616

Thailand

Dr. Varaporn Bovornsiri
 Faculty of Education
 Chulalongkorn University
 Phaya Thai, Bangkok 10330, Thailand

Viet Nam

Prof. Lam Quang Thiep
 Faculty of Education, Vietnam National University
 144 Xuan Thuy Str., Hanoi, Viet Nam

France

Dr. Thierry Malan
 28-30 rue des peupliers
 F 75013 Paris, France

Germany

Dr. Gerdi Jonen
 Sekretariat der Staendigen Konferenz der Kultusminister der Laender in der Bundesrepublik
 Deutschland
 Informationsstelle der Laender im EU-Bildungsinformationsnetz EURYDICE
 Lennestrasse 6, 53113 Bonn, Germany

The United Kingdom

Dr. Cloud Bai-Yun

Head of UK NARIC / UK NRP

ECCTIS 2000 Oriel House

Oriel Road, Cheltenham, GL50 1XP, U.K.

The United States of America

Dr. E. Stephen Hunt, Manager

U.S. Network for Education Information (USNEI)

International Affairs Staff , U.S. Department of Education

400 Maryland Avenue, SW

Washington, DC 20202-8401, U.S.A.